

-DO NOT SCALE THE DRAWING
-REMOVE ALL BURRS AND SHARP EDGES

-UNLESS NOTED OTHERWISE, ALL DIMENSIONS
-ARE IN MILLIMETRES (mm)

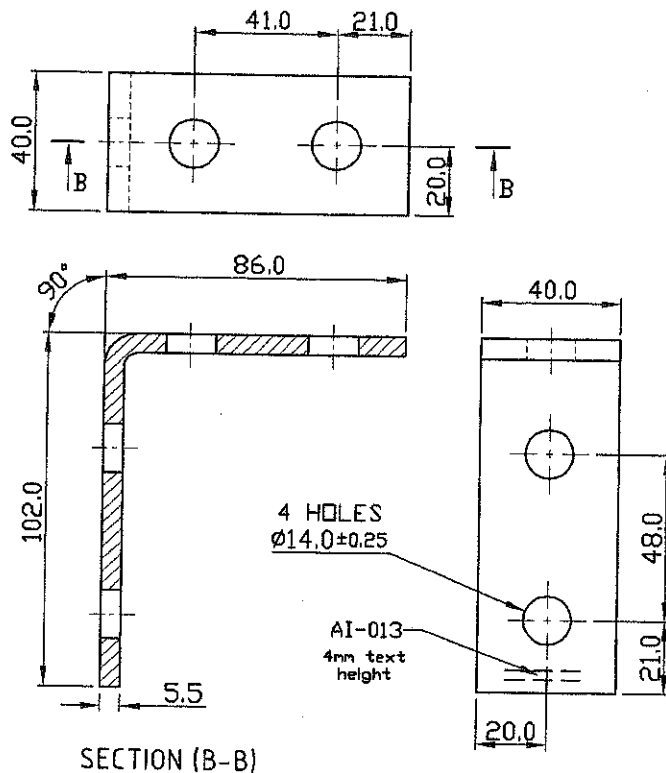

SECTION (B-B)

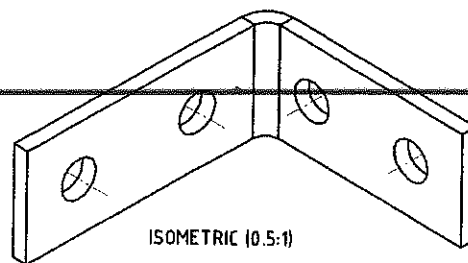

ISOMETRIC (0.5:1)

90° Brackets

STOCK NO	DESCRIPTION	REF
12051	2 Hole	P1026
12053	3 Hole	P1326
12055	4 Hole	P1325

'A' 25/08/10	Linear Tolerances changed from ISO 2 to 5mm & angular Tol. added -40.5°	C.H.
REV. DATE	Revision note	Signature

MATERIAL	MILD STEEL	TOLERANCE U.N.O.	SCALE:- 0.5:1	DRAWN BY:-	
WEIGHT	284 grams	DIMS. ±1mm		APPROVED BY:-	
FINISH	GALVANISED 50-70 MICRONS	ANGLES ± 0.5°		DATE:-	Apr-1998