

-DO NOT SCALE THE DRAWING
-REMOVE ALL BURRS AND SHARP EDGES

-UNLESS NOTED OTHERWISE, ALL DIMENSIONS
-ARE IN MILLIMETRES (mm)

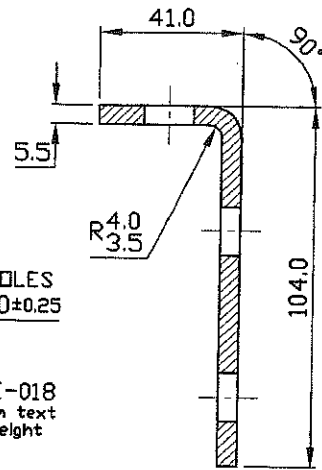

SECTION (B-B)

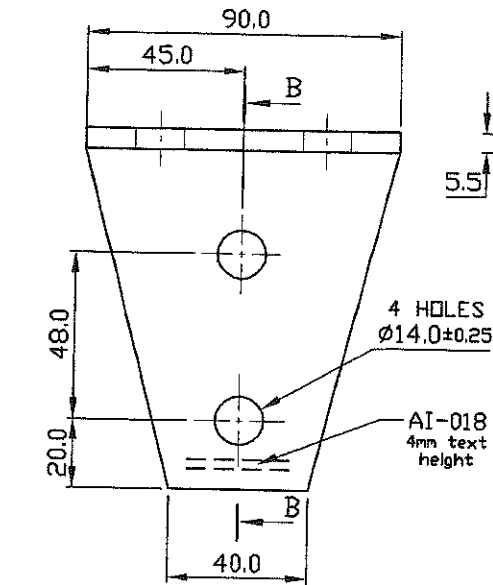
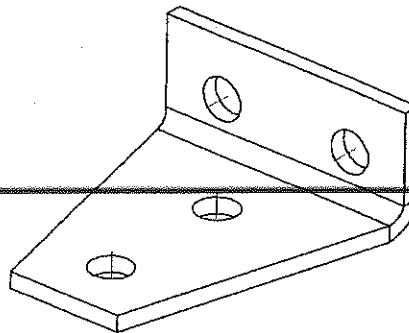
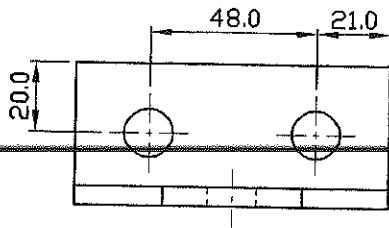

ISOMETRIC (0.5:1)

90° Bracket

STOCK NO	SIZE	REF
12181	96 x 90 x 41mm	P2072-S1

REV. DATE	Revision note	Signature
A' 25/08/10	Linear tolerances changed from ±0.2 to ±0.1mm & angular Tol. added ±0.5°	C.H.

MATERIAL	MILD STEEL	TOLERANCE U.N.O.	SCALE:- 0.5:1	DRAWN BY:-	
WEIGHT	4.01 grams	DIMS. ±1mm		APPROVED BY:-	
FINISH	GALVANISED 50-70 MICRONS	ANGLES ± 0.5°		DATE:-	Apr-1998