



Brymec 

**Brymec Copper Press
Technical Manual 2023**



Contents

Introduction to Brymec	4
Environmental Model	5
Brymec Copper Press System Introduction	6
Key Features and Advantages	8
Technical Information	
Certification and Applications	10
Corrosion and Expansion	12
Installation Design Considerations	16
Spacing Requirements	17
Support Centres	18
Brazing near Fittings	19
Compatible Tooling	20
Testing Procedures	22
Flushing	24
Product Range	25
Installation	
Installation Procedure	40
Brymec Training Programme	42
Brymec Technical Support	43
Warranty	44
Case Studies	46
General Information	50

➤ Introducing Brymec

Our philosophy has always been to provide the ultimate convenience and peace of mind to our clients. This also includes ensuring that you have the best possible products to select from.

By investing in innovation, we have been able to engineer our own range of products, all manufactured to our exacting specifications to deliver quality solutions for the Building Services Industry.

Every one of our Brymec products is manufactured to the highest quality standards possible and are backed up by our in-house technical support, robust quality controls and industry-leading guarantees.

Our innovative approach simplifies your supply chain, giving you direct access to the manufacturer. This gives you greater control and confidence in Brymec being the right partner for you.

With almost 50 years of experience, we understand the challenges you face and the solutions you require.

This complete understanding of industry products and systems enable us to collaborate with you more effectively and efficiently, to deliver a more comprehensive range of products that are specific to your needs.





➤ Our 3 Step Approach to an **Environmentally Friendly Build...**

Brymec cuts down the movement of products, which cuts the impact to the environment

This helps our customers reduce their carbon footprint of the products they buy from us

Traditional Model

- 1 Manufacturer
- 2 European Distribution
- 3 UK Distribution
- 4 Merchant Central Distribution
- 5 Branches
- 6 Construction Site

Our Environmentally Friendly Business Model



Brymec Copper Press System

The use of Press Fit for a quicker and improved method for pipework connection started over 50 years ago and has greatly increased to assist the industry to reduce time, cost and carbon footprint. There have been further developments over the year such as the addition of Stainless Steel ranges.

Benefits of Brymec Press Fit – the Five S's

There are many benefits in using Brymec Copper Press Fit connections for a quick and permanent joint:

- **Speed** of installation
- **Simplicity** of planning and installing a project
- **Safety** – no risk of fire, fire risk or fire watch times
- **Solder Free** – no need for consumables such as Solder, Flux, Brazing Rods, heat mats, rags, gas
- **Savings** due to efficiency

We have used our knowledge of what Engineers, Designers and Installers require to make sure that the Brymec Copper Press system has the unique features that will make a difference to your project.

The Copper Press System is an important part of the full range on Brymec Press Fit Products, which includes Gas Press Fit and Stainless Press Fit in all sizes from 15mm up to 108mm.

This tried and proven range has been engineered utilising our many years of product excellence and design to provide utmost confidence in the quality, security and ease of install with our system.

As well as market leading Quality Control and ability to deliver a project in a way that reduces time and cost, we have several unique features which give ultimate satisfaction. Our track record of successful projects range from vital fast track projects to use on some of the most prestigious buildings in the UK, and are evidence that Brymec Copper Press is the product of choice.



➤ Key Features and Advantages

The Brymec Copper Press System has several key advantages including unique products and designs.

With our product the combination of features and unique details is designed to provide the user with the easiest and most reliable installation. This is coupled with best practice standards from the start of manufacture to the completion of a project.



LEAK PATH DETECTION

This feature allows a fitting to have a slight leak that is visible under initial pressure to clearly identify if the fitting has not been crimped. The uniquely designed EPDM O-ring allows the medium to seep past the seal prior to being crimped. Once crimped a leak proof seal is created.

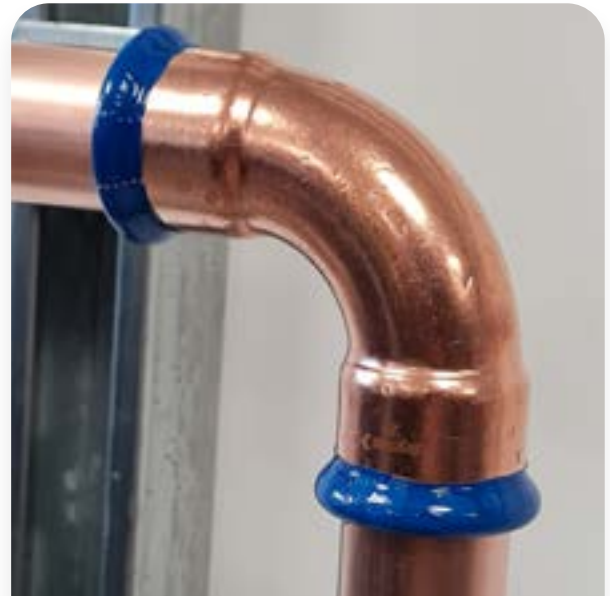

VISUAL CRIMP INDICATOR

The visual crimp indicator provides a clear visual confirmation if a fitting has been crimped or not.

Each gasket housing has a blue indicator ring which peels off once the fitting has been crimped.

These two features above provide certainty that unpressed fittings will be identified.



FRICITION FIT

Our unique fitting design removes the need to support loosely fitting pipe and fittings during the installation process or else having to crimp each fitting as you go. Fittings can be dry fitted to create your pipework layouts and will hold position, greatly speeding up the installation process.



manifold installations without the need for multiple cuts of copper tube and tees. The number of items and joints compared to conventional methods is greatly reduced, saving time and resources. The Manifold Tee allows you to accurately space pipework to allow for water meter assemblies, valves or metering points.



COPPER THREADED FITTINGS

All adaptors and union fittings are manufactured with a copper BSP thread as opposed to traditional brass materials. This means our fittings are 100% lead free providing a safer option for potable water. The risk of dezincification that comes with brass fittings is eliminated in our Copper press range meaning all fittings are suitable for Chilled Water applications. Our threaded components also have the same malleability as the full range of our fittings.

MANIFOLD TEE

The patent pending Brymec Copper Press Manifold Tee is a product that is unique to Brymec. The Manifold Tee allows installers to quickly and easily fabricate water distribution

Technical Information

➤ Certification

Brymec Copper Press fittings are independently tested and comply with the requirements of Water Regulations Advisory Scheme (WRAS). This means that the fittings are of an appropriate quality and standard as defined in The Water Supply (Water Fittings) Regulations 1999, The Water Supply (Water Fittings) (Scotland) Byelaws 2014, The Water Supply (Water Fittings) Regulations (Northern Ireland) 2009 and all other applicable WRAS requirements.



➤ Technical Data & Applications

Application	Comment	Pressure	Temp. (°C)
Hot and Cold potable water	Vented or unvented pressurised systems supplying cold or hot water for drinking or sanitary applications	16 Bar	Up to 95
Fire Services – Fire Sprinkler & Hose Reel	Capable of handling the required test pressure 17 Bar or 1.5 times the design pressure as specified (uk standard)	16 Bar	Up to 95
Spring Water	Must Contact Brymec	16 Bar	Up to 95
Pump circulated HW systems	Compliant with EN12828	16 Bar	Up to 95
Chilled Water Systems	See below for details	16 Bar	Up to 95
Compressed Air Systems	Compressed air classes 1-4 consistent with ISO 8573-1, max oil content <25g/m ³	16 Bar	Up to 95

Brymec WRAS Copper Press System for Chilled / Process circulating systems

- For chilled systems (normally operating circa 0-12°C), medium must be aqueous based (water/glycol mix). In any case operating temperature should be higher than the freezing temperature of the medium. The Brymec copper press system is not suitable if medium is expected to freeze at any point in the system – it must always be liquid.
- In all joints observe correct industry procedures, including tube preparation, marking, fixing/support and pressing.
- Installation to comply with the requirements of BS5970:2012 code of practice for the thermal insulation of pipe work – it is essential clean and dry pipework and fittings are enclosed within snug fitting insulation of uniform thickness and continuous integrity of vapour barrier is maintained. This should include suitable thermal insulating pipe support blocks with longitudinal and butt joints taped or glued throughout to ensure the continuous integrity of vapour barrier between block and lagging.
- There is no yellow brass within the wetted parts of the system, so no issues with dezincification that can occur with this material. (Yellow brass including Duplex & basic Copper Alloy parts.)

Working temperature for the system is within -20°C to 95°C at a maximum working pressure of 16 Bar.

Fittings are made from Copper Cu-DHP (CW024A) with Ethylene-propylene diene monomer (EDPM) O-ring with a Shore hardness of 70.

Design Considerations

Corrosion

Internal Corrosion Resistance:

Open systems:

When copper and oxygen meet, a protective outer oxide layer is formed which prevents a reaction between the copper and the medium it contains. Brymec Copper Press fittings are suitable for use with all drinking water solutions providing the following conditions are met:

The pH-value is equal or below 7.4

or

The pH-value is 7.0 to 7.4 and the TOC (total organic carbon) content is less than or equal to 1.5g/m³.

Closed systems:

Atmospheric oxygen does not exist in a closed heating or cooling systems so there is no risk of

corrosion. When water is heated, oxygen is released and discharged through the air vent valves installed in the system. The application of oxygen-binding materials requires the approval of Brymec.

External Corrosion Resistance:

Protection against external corrosion is not usually required due to the inherent properties of copper. However if the surroundings of copper tube and Brymec Copper press fittings contain nitrates, ammonia or sulphides external protection is necessary. For example if copper pipes are laid beneath a screed or plaster, some form of external protection must be used. This could be in the form of a plastic protective coating or other suitable impervious layer.

Linear Pipe Expansion

Changes in temperature cause pipework systems to expand and contract to different degrees depending on the temperature and material differences. It is of key importance that this thermal movement is considered when designing and installing pipework systems. Fixing pipework too rigidly, can restrict the natural expansion that comes from thermal fluctuations, causing mechanical stress and tension and compromise the integrity of joints.

The heat expansion co-efficient of copper can be calculated with the below formula:

$$\Delta L = L * \alpha * \Delta T$$

Whereby:

ΔL = total extension in mm. L = length of the pipe in m.

ΔT = Temperature fluctuation in °K.

α = Linear expansion coefficient ($\alpha = 0.0166$ mm/m for Copper pipe).

The following table can be used to calculate the thermal extension of copper:

Change in Length ΔL (mm) for copper with temperature difference Δt °C										
Pipe Length (m)	$\Delta t=10^\circ$	$\Delta t=20^\circ$	$\Delta t=30^\circ$	$\Delta t=40^\circ$	$\Delta t=50^\circ$	$\Delta t=60^\circ$	$\Delta t=70^\circ$	$\Delta t=80^\circ$	$\Delta t=90^\circ$	$\Delta t=100^\circ$
1	0.17	0.33	0.50	0.66	0.83	1.00	1.16	1.33	1.49	1.66
2	0.33	0.66	1.00	1.33	1.66	1.99	2.32	2.66	2.99	3.32
3	0.50	1.00	1.49	1.99	2.49	2.99	3.49	3.98	4.48	4.98
4	0.66	1.33	1.99	2.66	3.32	3.98	4.65	5.31	5.98	6.64
5	0.83	1.66	2.49	3.32	4.15	4.98	5.81	6.64	7.47	8.30
6	1.00	1.99	2.99	3.98	4.98	5.98	6.97	7.97	8.96	9.96
7	1.16	2.32	3.49	4.65	5.81	6.97	8.13	9.30	10.46	11.62
8	1.33	2.66	3.98	5.31	6.64	7.97	9.30	10.62	11.95	13.28
9	1.49	2.99	4.48	5.98	7.47	8.96	10.46	11.95	13.45	14.94
10	1.66	3.32	4.98	6.64	8.30	9.96	11.62	13.28	14.94	16.60
15	2.49	4.98	7.74	9.96	12.45	14.94	17.43	19.92	22.41	24.90
20	3.32	6.64	9.96	13.28	16.60	19.92	23.24	26.56	29.88	33.20

The basic principle is that there must always be adequate capacity for expansion between two fixed points.

The inherent elasticity of the pipework can often be used to compensate for expansion, however wherever there is a change in pipework direction it is necessary to arrange pipe clamps to provide sufficiently flexible pipe limbs.

If the pipework installation is buried or concealed, it is important that thermal expansion is not impeded, by encapsulating the pipes with elastic chloride-free material of sufficient thickness

If sufficient compensation for thermal expansion is not accommodated within the natural pipe routing the following measures can be taken:

- Expansion equalization joints (expansion bends)
- Fixed and Sliding points
- Expansion compensators

Expansion equalization Joints

There are three types of expansion equalization joints that can be used. These are U-shaped, Z-shaped or T-shaped. The formula for which these are calculated is as follows:

$$L_b = k \times \sqrt{(OD \times \Delta l)}$$

- L_b = expansion compensation length (mm)
- k = material constant - 0.0166 mm/m
- OD = outside diameter of the tube (mm)
- Δl = linear expansion that needs to be compensated (mm)

Z-Shaped or T-Shaped equalization joints:

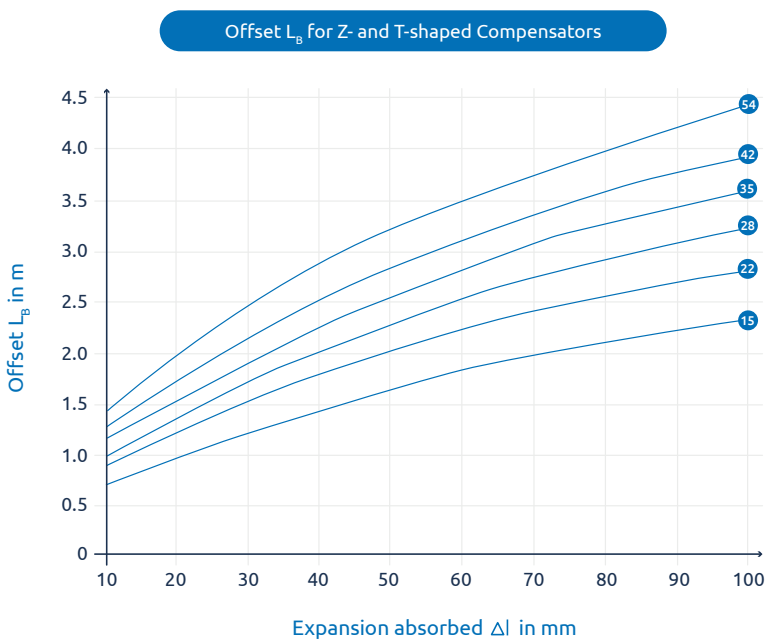
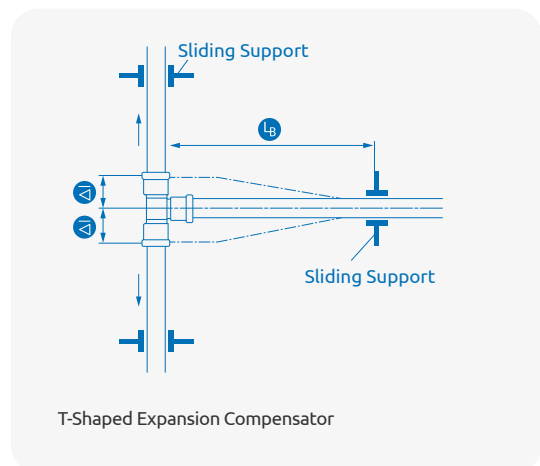
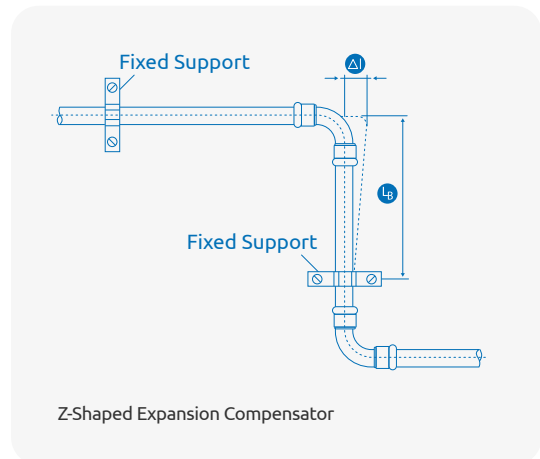

U-Shaped Equalization Joints:

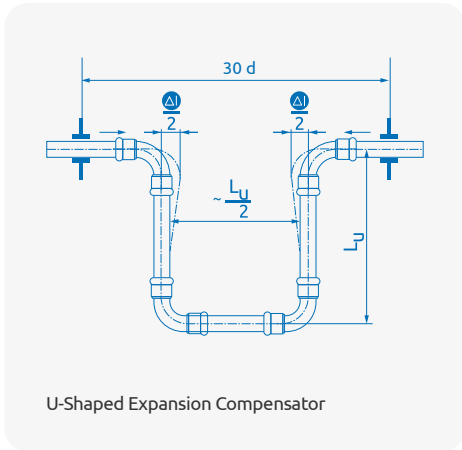

Formula

$$L_U = 0.032 \cdot \sqrt{OD \cdot \Delta l} \text{ (m)}$$

(OD and Δl in mm)

Offset L_U for U-shaped Expansion Compensators

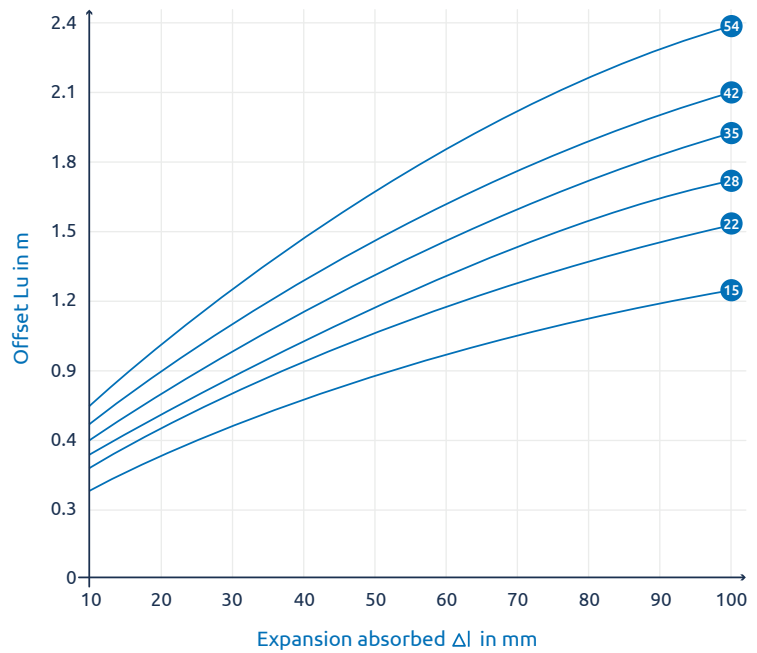

Commercial Axial Expansion Compensator:

When space is limited, the axial compensator provides a solution for expansion and contraction. It is an expansion joint with a corrugated bellow that allows movement, and well as dampening vibrations and reducing noise.

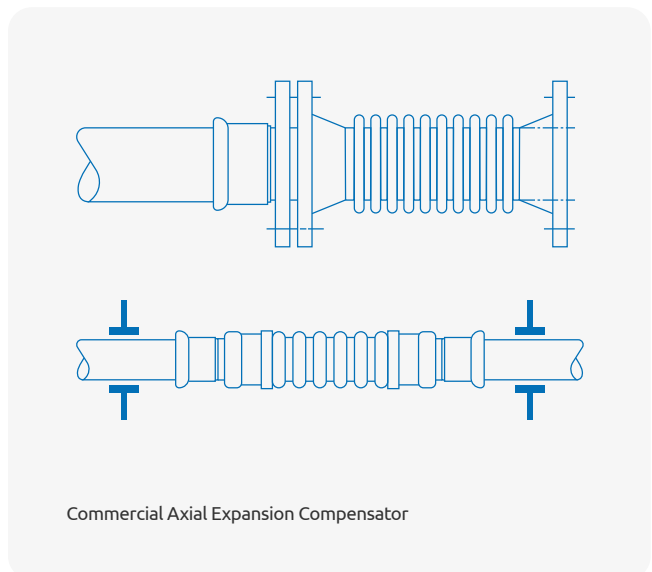

Installation Design Considerations

A minimum separation between fitting installation needs to occur to ensure the press forming does not possibly compromise either joint during installation.

Also ensure enough spacing is maintained between fittings and building fabric or system components allow unhindered access for the pressing tool for correct joint completion.

If required, consider pre-fabrication of pipe & fittings as a section which can be subsequently pressed in to the system at more suitable points.

The concentricity of copper tube wall thickness in the pipework can also affect the fittings integrity

to seal when they are installed too close together, or too close to any pipe bending radii.

It is required that pipe is concentric and straight for the expected joint position and the entire minimum spacing separation distance as indicated in the table below for Brymec press fittings by size of the fitting. This distance must be applied between any fittings as a minimum from fitting edge to fitting edge. This design requirement needs to be conformant to have warranty coverage on all Brymec press fittings.

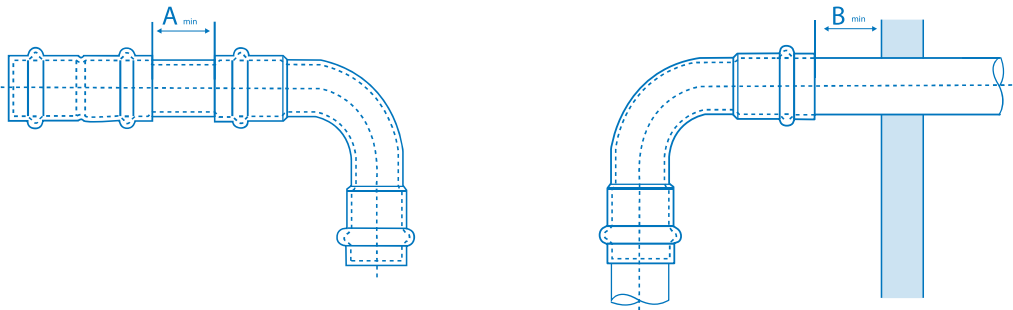

Minimum distances

Outside pipe diameter mm	Minimum distance (mm)	
	A min	B min
15	10	60
22	10	60
28	10	60
35	20	60
42	30	60
54	40	60
67	40	60
76	40	60
108	40	60

Spacing Requirements when Pressing

Space requirements when pressing with pressing jaws for mounting on a smooth wall, in corners and in ducts



d (mm)	A (mm)	B (mm)	C (mm)	D (mm)	E (mm)
15	20	56	20	75	131
22	20	65	31	80	150
28	25	75	31	80	150
35	30	75	31	80	170

Space requirements when pressing with pressing sling for mounting on a smooth wall, in corners and in ducts

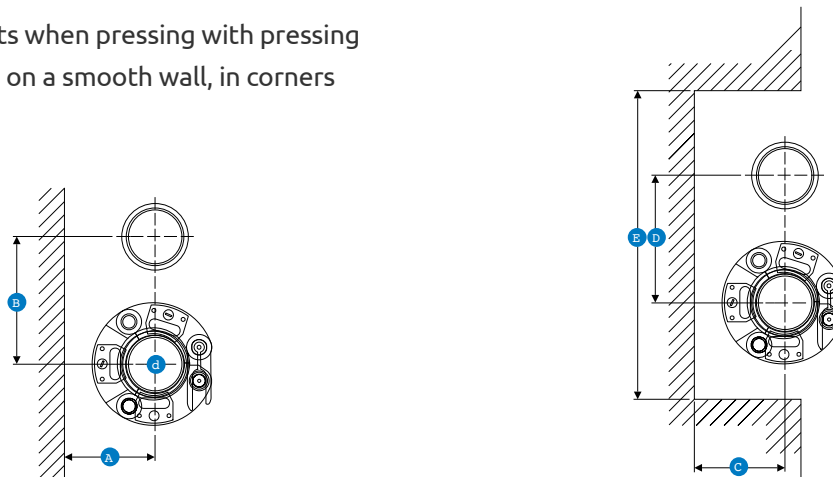

d (mm)	A (mm)	B (mm)	C (mm)	D (mm)	E (mm)
42	75	115	75	115	265
54	85	120	85	120	290
67	95	140	95	140	330
76	110	140	110	140	350
108	140	170	140	170	450

Support Centres

Pipes must be connected directly to buildings using standard commercial clamps and may not be connected to other pipes. Clamps with a rubber lining must be used so that they cannot transfer any structure-borne sound. The clamp spacing is shown in the following table.

Maximum spacing of support brackets for copper tube to BS EN 1057

Size (mm)	Horizontal Pitch	Vertical Pitch
15	1.2m	1.8m
22	1.8m	2.4m
28	1.8m	2.4m
35	2.4m	3.0m
42	2.4m	3.0m
54	2.7m	3.0m
67	3.0m	3.6m
76	3.0m	3.6m
108	3.0m	3.6m

Pipework must also be supported within 0.3 metres of a change in direction.

Brazing near Brymec Press Fittings

No hot works, (soldering, welding or annealing) can be performed within a minimum defined distance of any installed Brymec press fitting.

The minimum separation distance by size is stated in the table below.

Considerations should be made prior to any installation that may require any soldering, welding or annealing to ensure it is done prior to installation with Brymec press fittings.

If the defined minimum separation distances cannot be achieved and any hot work detailed

needs to be performed, preventive measures need to be applied to ensure the installed fitting O-ring maximum operating temperature, defined in this document by O-ring Type, is not exceeded at any time by heat transfer or thermal conductivity.

It should also be noted that considerations also need to be taken to ensure installation location will not affect Brymec press fittings maximum operating temperature with radiant heat and/or heat transfer during installation, commissioning and operation.

Tube Size	Minimum Clearance (mm)
15mm	400
22mm	600
28mm	800
35mm	1000
42mm	1200
54mm	1500
67mm	1800
76mm	2000
108mm	2500

Compatible Press Tools

15-35mm Compact Machines

Manufacturer	Press Machine	Press Jaws	Jaw Profile
Rothenberger	Romax Compact TT	Rothenberger Compact	M
REMS	Mini Press ACC	Rems Mini	M
Novopress	ACO103	NovoPress - PB1	M
Hilti	NPR 19-A/Nuron NPR 19-22	NPR PM M Jaw	M
Ridgid	RP 240/241/219	Compact Series M-Jaws	M
Klauke	MAP215	SBM	M
	MAP219	SBMX	
Milwaukee	M12 HPT	J12 Jaws	M
	M18 HPT	J18 Jaws	

15-54mm Standard Machines

Manufacturer	Press Machine	Press Jaws	Jaw Profile
Rothenberger	Romax 3000/4000/AC ECO	Rothenberger Standard Jaws (15-35mm)	M
		Rothenberger Standard Collars (42&54mm) + ZBS1 Adaptor	
REMS	Power-Press ACC/Akku-Press ACC/Power-Press XL ACC	REMS Standard Tongs (15-35mm)	M
		REMS Standard Press Rings (42&54mm) + Z2 Adaptor	
Novopress	ACO203/ECO203	NovoPress - PB2 Jaw (15-35mm)	M
		NovoPress - ZB202 Sling (42&54mm) + ZB203 Adaptor	
Hilti	NPR 32-A/Nuron NPR 32-22	NPR PS M Jaw (15-35mm)	M
		NPR PR M Press Ring (42&54mm) + NPR PA 2 Adaptor	
Ridgid	RP 350/351/352-XL	Ridgid Standard M-Profile Jaws (15-35mm)	M
		Ridgid Standard M-Profile Rings (42&54mm) + 69908 Actuator	
Klauke	UAP 332/432	SB Standard Jaws (15-35mm)	M
		SSK M Pressing Chain (42&54mm) + SBKQC Adaptor	
Milwaukee	M18 HPT	J18 (15-35mm)	M
		RJ18 Ring (42&54mm) + RJA-1 Adaptor	

67-108mm Standard Machines

Manufacturer	Press Machine	Press Jaws	Jaw Profile
REMS	Akku-Press XL	PR-3S Pressing Rings + Z7 Adaptor (Only one press on 108mm fittings)	M
	Power-Press XL ACC	PR-3S Pressing Rings + Z6 Adaptor (Only one press on 108mm fittings)	
Novopress	ACO203/ECO203/ACO203XL	S330 Sling - 67-108mm + ZB221 Adaptor (108mm 1st Press)	M
		S322 Sling (Copper Only) + ZB222 (108mm 2nd Press)	
Hilti	NPR 32-A Pistol-Grip/Nuron NPR 32 XL-22	NPR PR M Press Ring (67-108mm) + NPR PA2 Adaptor (67mm)/NPR PA3 Adaptor (76&108mm 1st Press)/NPR PA4 Adaptor (108mm 2nd Press)	M
Ridgid	RP 352-XL	32 kN-XL Press Ring M (67-108mm) + 32 kN-XL Actuator. (Only one press on 108mm fittings)	M
Klauke	UAP1001120	BP HP Pressing Chain (76-108mm)	M



Testing Procedures

The design of the Brymec copper press fittings allows for water and/or air to pass the sealing element if a joint is unpressed. This allows unpressed joints to be identified when testing the system using the approved procedure below.

Once the fitting is pressed, the O-ring is compressed, and joint seal completed, creating a leak free permanent joint. Also the coloured plastic foil ring will be destroyed during the press cycle, so pressed fittings are visibly defined from unpressed fittings.

Final testing of the system should be done in accordance with BESA TR/6 Guide to Good Practice - Site Pressure Testing of Pipework and BS EN 806.

The pressure test should consist of two elements:

- A leak test to ensure joint integrity and to confirm that fittings are correctly crimped
- A tightness test which checks the system for strength

There are some important steps that need to be taken before any test is conducted.

- Air vents need to be installed at all high points in the system to allow the removal of air when the system is being filled. These need to be closed off for a pressure test. The low points of the system need to have drain valves fitted.
- Any open ends on the system being tested need to be sealed off and any valves at the extremity of the areas being tested need to be closed
- Valves within the section being tested must be open
- Check the test gauge being used has been calibrated. A calibration certificate should be provided with the gauge being used.

There two main types of pressure test that can be used. These are a Hydraulic test (water pressure test) or a Pneumatic Test (Air test or Nitrogen Pressure Test).

The pneumatic test should be conducted first to ensure joint integrity. Once this test is passed a Hydraulic test needs to be done to check the system for strength. The following are recommendations only of how to conduct an initial pneumatic test followed by a hydraulic test.

Pneumatic Pressure Testing:

- Connect the compressor with hoses, shut off valves and calibrated pressure gauge at the lowest point of the system.
- Ensure all air release valve at the high point in the system are closed off.
- A low pressure test at maximum 0.5 bar should be conducted initially to identify any unpressed fittings.
- Inspect each joint with a proprietary leak check liquid/spray for any visual signs of leakage.
- Slowly increase the pressure in 0.1 bar increments until the pressure reaches the required test pressure of 0.5 bar.
- The test pressure of 0.5 bar is to be maintained/pumped for a minimum time period of 30 minutes.
- If the pressure is maintained for one hour without any leakages or drop in pressure, the test is passed.
- If there are any uncrimped fittings identified these will need to be crimped, ensuring that the tube is inserted correctly. Any leaking fittings need to be replaced.

Hydraulic Pressure Testing:

- Commence slowly filling the system and visually inspect the pipework being tested for leaks as the system water circulates.
- As the system fills, air needs to be released from all the high points to ensure the system fills completely with water. Once free of air the high level air release valves need to be closed off, and any circulation pump should be turned off.
- Connect a hand pump, valves and pressure gauge at the lowest point of the system.
- Using the hand pump, start increasing the pressure in the system in 0.5 bar increments until the required test pressure is reached.
- The required test pressure should be 1.5 times the normal working pressure of the system.
- Once the required pressure is reached, isolate the hand pump and wait 30 minutes to allow the system to settle
- As the system settles there may be a drop in pressure. If the pressure drops but there are no obvious leaks, open the valve and increase the pressure again using the hand pump.
- Once the required test pressure is reached, it needs to be left for an hour. Continually check the pipework for any leaks during this period.
- If the pressure is maintained for one hour without any visible leakages or drop in pressure, the test is considered to be passed.
- If there are any leaking fittings identified these will need to be replaced.

For the general systems that are carrying water and have metal pipework BESA TR/6 notes for testing pressure and time:

“For all Metal Pipework Systems*, a test pressure of at least 1.5 times the maximum working pressure of the system shall be applied.

If the test pressure holds steady for one hour, the system is deemed to be satisfactory”

BESA – Guide to Good Practice – TR/6

*excluding fire systems and compressed air as these will be covered under local codes and regulations.

➤ Flushing

Although a Press Fit installation is the cleanest method of connecting copper pipework, an industry requirement is to flush a completed system to remove any particles or debris that could potentially cause blockages or be detrimental to successful cleaning and water treatment processes. This will ensure that any risk of contamination or risk of corrosion is minimised.

For the best possible results from flushing, the system should be carefully designed with sufficient venting capability, protection of damage to equipment by bypassing where required, and

adequate drainage points. Flushing should be carried out in a planned manner and different systems eg Hot and Cold should be flushed individually using the correct velocities for the largest diameter pipe to ensure that most of the debris is removed by the flow. If there is a requirement for chemical cleansing then please check with Brymec to confirm compatibility.

Guidance can be obtained in BSRIA Guide BG-29/2021 Pre-Commissioning Cleaning of Pipework Systems 6th Edition.



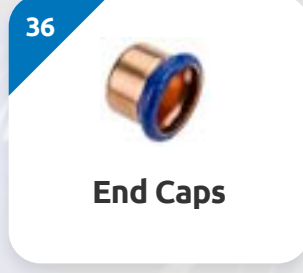
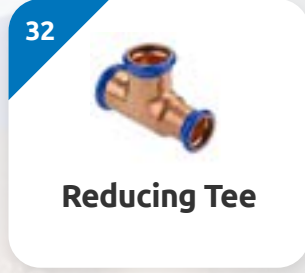
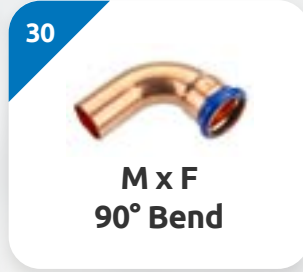

Product Range

➤ Coupling

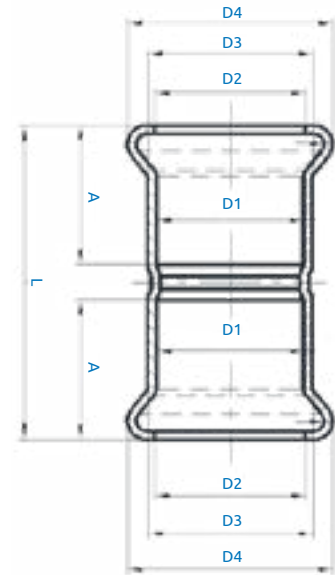

STOCK NO.	D1	D2	D3	D4	A	L
27940	15	15.6	18	23	19	44
27941	22	22.8	25	31.3	20	46
27942	28	28.8	31	37.4	22	50
27943	35	35.7	38.3	44.7	25	58
27944	42	42.8	45.3	53.5	29	67
27945	54	54.8	57.3	65.3	34	80
27946	67	69.1	71.7	82.6	48	107
27947	76	78.6	81.1	94.4	49	108
27949	108	110.9	113.8	132.1	65	147

➤ Reducing Coupling

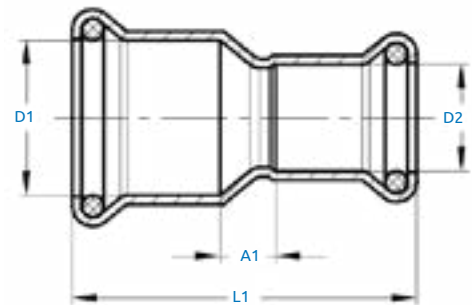

STOCK NO.	D1	D2	L1	A1
27900	22	15	50	8.5
27901	28	15	55	12
27902	28	22	52	8
27903	35	22	61	14
27904	35	28	60	10
27905	42	22	70	19
27906	42	28	67.5	14.5
27907	42	35	68	10.5
27908	54	28	81	23
27909	54	35	81	19
27910	54	42	81	14

Fitting Reducer

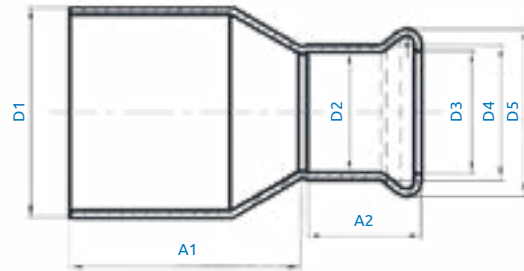

STOCK NO.	D1	D2	D3	D4	D5	A1	A2
27915	22	15	15.6	18	23	31.5	19
27916	28	15	15.6	18	23	36.5	19
27917	28	22	22.8	25	31.3	32	20
27918	35	22	22.8	25	31.3	43	20
27919	35	28	28.8	31	37.4	40	20
27920	42	22	22.8	25	31.3	49	20
27921	42	28	28.8	31	37.4	46	20
27922	42	35	35.7	38.3	44.7	44	25
27932	54	28	28.8	31	37.4	61	20
27923	54	35	35.7	38.3	44.7	58	25
27924	54	42	42.8	45.3	53.5	53	29
28231	67	28	28.8	31	37.4	88	20
28232	67	35	35.7	38.3	44.7	84	25
28233	67	42	42.8	45.3	53.5	78	29
27925	67	54	54.8	57.3	65.3	70	34
28234	76	35	35.7	38.3	44.7	82	25
27926	76	54	54.8	57.3	65.3	76	-
28236	76	67	69.1	71.7	82.6	64	49
28237	108	42	42.8	45.3	53.5	130	29
27929	108	54	54.8	57.3	65.3	113	-
28238	108	67	69.1	71.7	82.6	108	48
27930	108	76	78.6	81.1	94.4	98	-

➤ Slip Coupler

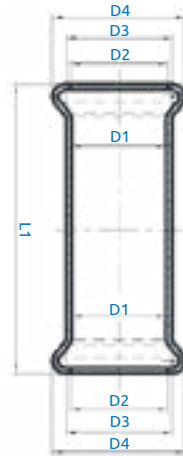

STOCK NO.	D1	D2	D3	D4	L1
27950	15	15.6	18	23	80
27951	22	22.8	25	31.3	84
27952	28	28.8	31	37.4	91
27953	35	35.7	38.3	44.7	95
27954	42	42.8	45.3	53.5	115
27955	54	54.8	57.3	65.3	139
27956	67	69.1	71.7	82.6	220
27957	76	78.6	81.1	94.4	230

➤ Spigot Manifold Tee

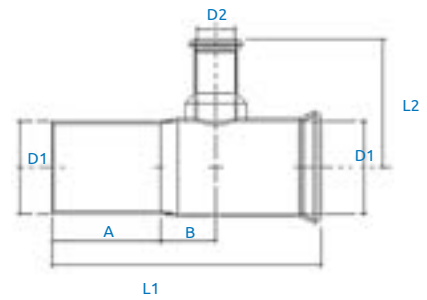

STOCK NO.	D1 (mm)	D2 (mm)	A (mm)	B (mm)	L1 (mm)	L2 (mm)
27897	54	22	63	32	157	75
27898	54	28	63	38	163	62.5

➤ F x F 90° Bend

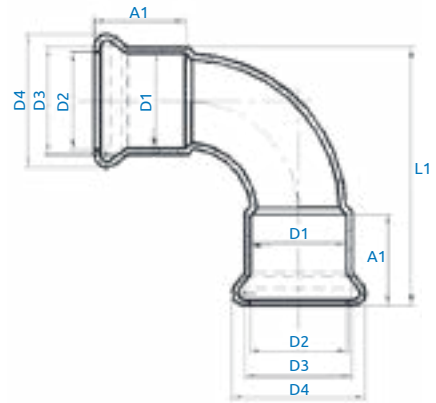

STOCK NO.	D1	D2	D3	D4	A1	L1
27810	15	15.6	18	23	19	47
27811	22	22.8	25	31.3	20	60
27812	28	28.8	31	37.4	22	73
27813	35	35.7	38.3	44.7	25	84
27814	42	42.8	45.3	53.5	29	99
27815	54	54.8	57.3	65.3	34	126
27816	67	69.1	71.7	82.6	48	163
27817	76	78.6	81.1	94.4	49	186
27819	108	110.9	113.8	132.1	65	256

➤ F x F 45° Bend

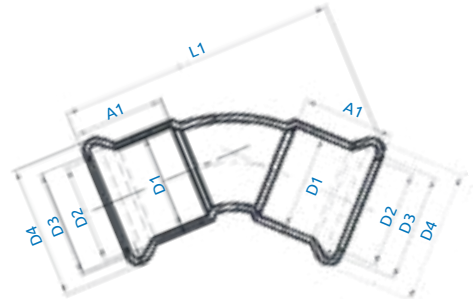

STOCK NO.	D1	D2	D3	D4	A1	L1
27830	15	15.6	18	23	19	54
27831	22	22.8	25	31.3	20	64
27832	28	28.8	31	37.4	22	74
27833	35	35.7	38.3	44.7	25	82
27834	42	42.8	45.3	53.5	29	97
27835	54	54.8	57.3	65.3	34	118
27836	67	69.1	71.7	82.6	48	169
27837	76	78.6	81.1	94.4	49	184
27839	108	110.9	113.8	132.1	65	253

➤ M x F 90° Bend

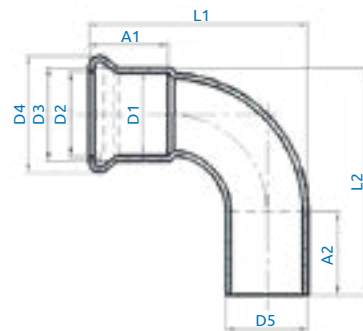

STOCK NO.	D1	D2	D3	D4	D5	A1	A2	L1	L2
27800	15	15.6	18	23	15	19	22	44.5	59
27801	22	22.8	25	31.3	22	20	23	57.5	71
27802	28	28.8	31	37.4	28	20	25	70	79.5
27803	35	35.7	38.3	44.7	35	28	25	81.5	92
27804	42	42.8	45.3	53.5	42	29	32	96	107.5
27805	54	54.8	57.3	65.3	54	34	37	123	133.5
27806	67	69.1	71.7	82.6	67	49	52	158	179
27807	76	78.6	81.1	94.4	76	49	54	184	201
27809	108	110.9	113.8	132.1	108	65	71	253	266

➤ M x F 45° Bend

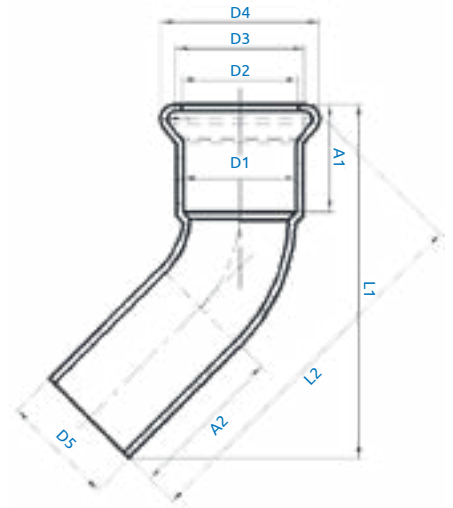

STOCK NO.	D1	D2	D3	D4	D5	A1	A2	L1	L2
27820	15	15.6	18	23	15	19	22	57.5	62
27821	22	22.8	25	31.3	22	20	23	69.5	74.5
27822	28	28.8	31	37.4	28	20	25	80	86
27823	35	35.7	38.3	44.7	35	28	25	86	90.5
27824	42	42.8	45.3	53.5	42	29	32	103	109
27825	54	54.8	57.3	65.3	54	34	37	123	129
27826	67	69.1	71.7	82.6	67	49	52	177	178
27827	76	78.6	81.1	94.4	76	49	52	184	193
27829	108	110.9	113.8	132.1	108	65	68	253	267

➤ Equal Tee

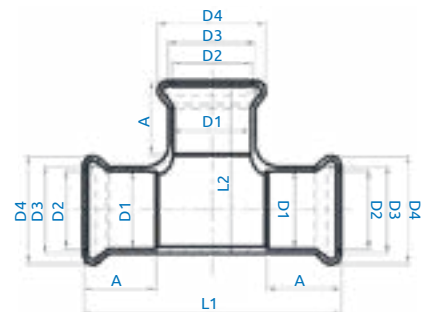

STOCK NO.	D1	D2	D3	D4	A	L1	L2
27850	15	15.6	18	23	19	64	41
27851	22	22.8	25	31.3	20	74	49.5
27852	28	28.8	31	37.4	22	84	57
27853	35	35.7	38.3	44.7	25	100	69
27854	42	42.8	45.3	53.5	29	116	86
27855	54	54.8	57.3	65.3	34	139	98
27856	67	69.1	71.7	82.6	48	189	133
27857	76	78.6	81.1	94.4	49	208	139.5
27859	108	110.9	113.8	132.1	65	273	196

Reducing Tee

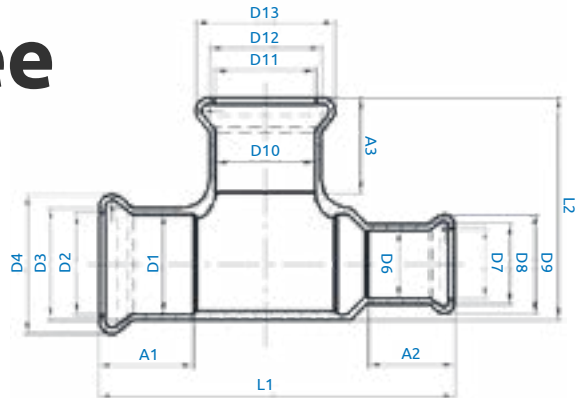

STOCK NO.	D1	D2	D3	D4	D6	D7	D8	D9	D10	D11	D12	D13	A1	A2	A3	L1	L2
27860	15	15.6	18	23	15	15.6	18	23	22	22.8	25	31.3	19	19	20	74	43
27861	22	22.8	25	31.3	15	15.6	18	23	15	15.6	18	23	20	19	19	80.5	50.5
27862	22	22.8	25	31.3	22	22.8	25	31.3	15	15.6	18	23	20	20	19	74	50.5
27863	22	22.8	25	31.3	15	15.6	18	23	22	22.8	25	31.3	20	19	20	83.5	49.5
27865	28	28.8	31	37.4	22	22.8	25	31.3	15	15.6	18	23	22	20	19	85	56
27866	28	28.8	31	37.4	28	28.8	31	37.4	15	15.6	18	23	22	22	19	84	56
27867	28	28.8	31	37.4	22	22.8	25	31.3	22	22.8	25	31.3	22	20	20	88	57.5
27868	28	28.8	31	37.4	28	28.8	31	37.4	22	22.8	25	31.3	22	22	20	84	56.5
27869	28	28.8	31	37.4	15	15.6	18	23	28	28.8	31	37.4	22	19	22	95	57.5
27870	28	28.8	31	37.4	22	22.8	25	31.3	28	28.8	31	37.4	22	20	22	91	57.5
27872	35	35.7	38.3	44.7	35	35.7	38.3	44.7	15	15.6	18	23	25	25	19	84	65
27874	35	35.7	38.3	44.7	28	28.8	31	37.4	22	22.8	25	31.3	25	22	20	95	67.1
27875	35	35.7	38.3	44.7	35	35.7	38.3	44.7	22	22.8	25	31.3	25	25	20	91	63
27876	35	35.7	38.3	44.7	28	28.8	31	37.4	28	28.8	31	37.4	25	22	22	104	65
27877	35	35.7	38.3	44.7	35	35.7	38.3	44.7	28	28.8	31	37.4	25	25	22	100	64
27880	42	42.8	45.3	53.5	42	42.8	45.3	53.5	15	15.6	18	23	29	29	19	98	83
27881	42	42.8	45.3	53.5	42	42.8	45.3	53.5	22	22.8	25	31.3	29	29	20	98	76
27882	42	42.8	45.3	53.5	42	42.8	45.3	53.5	28	28.8	31	37.4	29	29	22	112	71.5
27884	42	42.8	45.3	53.5	42	42.8	45.3	53.5	35	35.7	38.3	44.7	29	29	25	112	74.5
27896	42	42.8	45.3	53.5	35	35.7	38.3	44.7	42	42.8	45.3	53.5	29	25	29	122	85.6
27885	54	54.8	57.3	65.3	54	54.8	57.3	65.3	22	22.8	25	31.3	34	34	20	123	76
27886	54	54.8	57.3	65.3	54	54.8	57.3	65.3	28	28.8	31	37.4	34	34	22	123	83.5
27887	54	54.8	57.3	65.3	54	54.8	57.3	65.3	35	35.7	38.3	44.7	34	34	25	122	86.5
27888	54	54.8	57.3	65.3	54	54.8	57.3	65.3	42	42.8	45.3	53.5	34	34	29	138	93.5
28255	67	69.1	71.7	82.6	67	69.1	71.7	82.6	28	28.8	31	37.4	48	48	22	179	129
27889	67	69.1	71.7	82.6	67	69.1	71.7	82.6	54	54.8	57.3	65.3	48	48	34	178	129
28260	76	78.6	81.1	94.4	76	78.6	81.1	94.4	35	35.7	38.3	44.7	49	49	25	188	139.5
27890	76	78.6	81.1	94.4	76	78.6	81.1	94.4	54	54.8	57.3	65.3	49	49	34	188	130.5
27893	108	110.9	113.8	132.1	108	110.9	113.8	132.1	54	54.8	57.3	65.3	65	65	34	216	163

Female Branch Reducing Tee

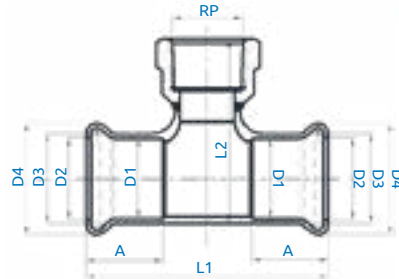

STOCK NO.	D1	D2	D3	D4	A	L1	L2	RP
28101	15	15.6	18	23	19	64	48.5	1/2"
28102	22	22.8	25	31.3	20	74	55	1/2"
28104	28	28.8	31	37.4	22	84	63	1/2"
28106	35	35.7	38.3	44.7	25	91	68	1/2"
28108	42	42.8	45.3	53.5	29	98	75	1/2"
28110	54	54.8	57.3	65.3	34	123	83	1/2"

Male Adaptor

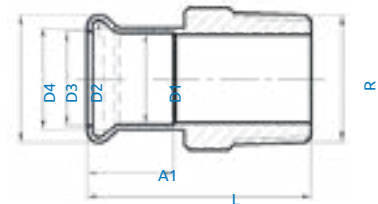

STOCK NO.	D1	D2	D3	D4	A1	L	R
28115	15	15.6	18	23	19	37	3/8"
28116	15	15.6	18	23	19	39	1/2"
28117	15	15.6	18	23	19	40	3/4"
28118	22	22.8	25	31.3	20	41	1/2"
28119	22	22.8	25	31.3	20	41	3/4"
28120	22	22.8	25	31.3	20	46	1"
28121	28	28.8	31	37.4	22	46	3/4"
28122	28	28.8	31	37.4	22	46	1"
28125	35	35.7	38.3	44.7	25	53	1 1/4"
28128	42	42.8	45.3	53.5	29	58	1 1/2"
28130	54	54.8	57.3	65.3	34	65	2"
28131	67	69.1	71.7	82.6	48	103	2 1/2"
28133	76	78.6	81.1	94.4	49	101	3"

Female Adaptor

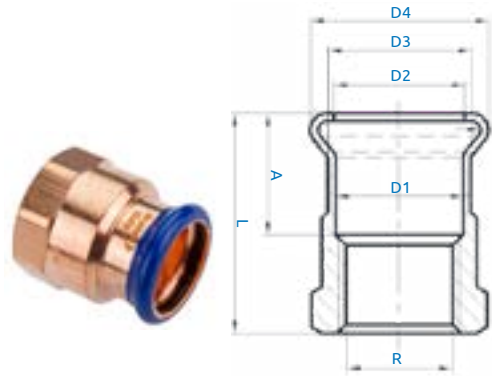

STOCK NO.	D1	D2	D3	D4	A	L	R
28151	15	15.6	18	23	19	40	1/2"
28153	22	22.8	25	31.3	20	38	1/2"
28154	22	22.8	25	31.3	20	40	3/4"
28157	28	28.8	31	37.4	22	47	1"
28160	35	35.7	38.3	44.7	25	52	1 1/4"
28163	42	42.8	45.3	53.5	29	56	1 1/2"
28165	54	54.8	57.3	65.3	34	65	2"
28166	67	69.1	71.7	82.6	48	97	2 1/2"
28169	76	78.6	81.1	94.4	49	101	3"

Male 90° Elbow

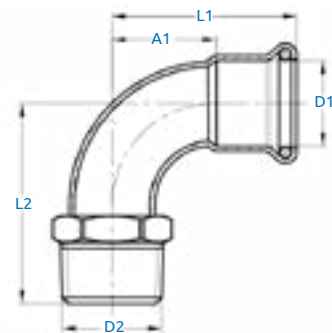

STOCK NO.	D1	D2	L1	A1	L2
28081	15	1/2"	38	18	47

Female 90° Elbow

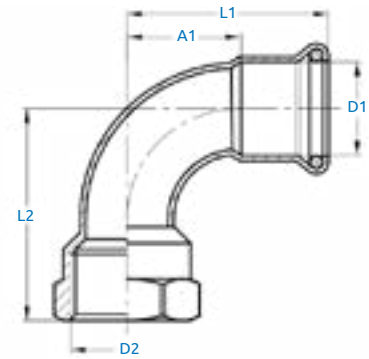

STOCK NO.	D1	D2	L1	A1	L2
28071	15	1/2"	38	18	43
28074	22	3/4"	47.5	26.5	52.5

Plug In Male Adaptor

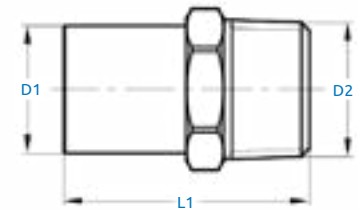

STOCK NO.	D1	D2	L1
28171	15	1/2"	47
28173	22	3/4"	50

Plug In Female Adaptor

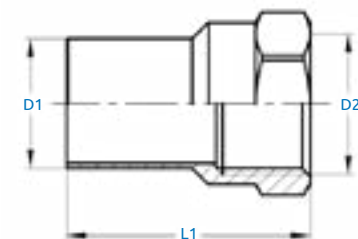

STOCK NO.	D1	D2	L1
28141	15	1/2"	44
28142	22	1/2"	46
28143	22	3/4"	46.5
28149	35	1"	54
28148	54	2"	71

Female Backplate Elbow

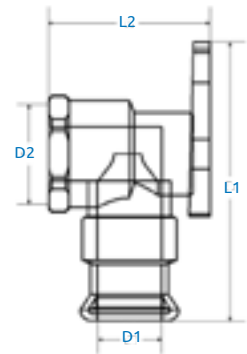

STOCK NO.	D1	D2	L1	L2
28225	15	1/2"	65	38

End Caps

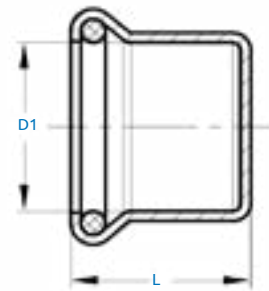

STOCK NO.	D1	L1
27960	15	23
27961	22	24.5
27962	28	26.5
27963	35	29.5
27964	42	34
27965	54	39
27966	67	64
27967	76	58

➤ Full Crossover



STOCK NO.	D1	L1	A1	A2	H
27845	15	109	39	50	25
27846	22	133	48	64	27

➤ Partial Crossover

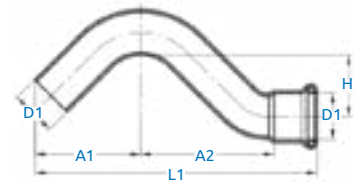

STOCK NO.	D1	L1	A1	A2	H
27845	15	109	39	50	25
27846	22	133	48	64	27

Male Union

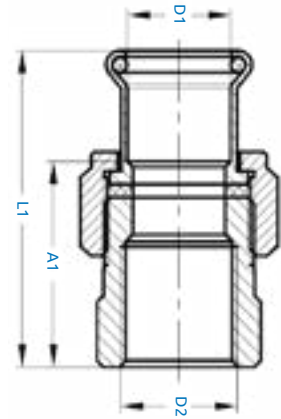

STOCK NO.	D1	D2	D3	D4	A	R	L1
28200	15	15.6	18	23	19	1/2"	58
28203	22	22.8	25	31.3	20	3/4"	64
28206	28	28.8	31	37.4	22	1"	71
28207	35	35.7	38.3	44.7	25	1 1/4"	81
28208	42	42.8	45.3	53.5	29	1 1/2"	85
28209	54	54.8	57.3	65.3	34	2"	98

Female Union

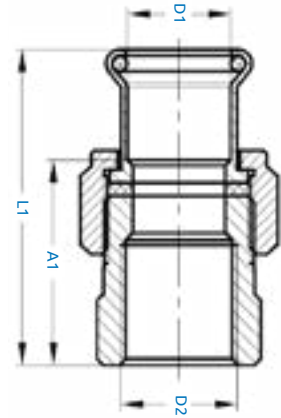

STOCK NO.	D1	D2	L1	A1
28190	15	1/2"	43	26
28192	22	3/4"	49.5	28.5
28195	28	1"	56	33
28196	35	1 1/4"	73.5	47.5
28197	42	1 1/2"	67	37
28198	54	2"	77	42

PN10/16 Crimping Flange

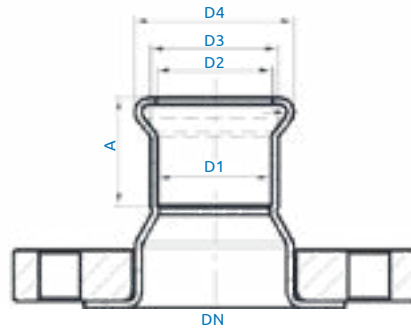

STOCK NO.	D1	D2	D3	D4	A	DN	NO. OF BOLT HOLES
28241	42	42.8	45.3	53.5	29	1 ¼"	4
28242	54	54.8	57.3	65.3	34	2"	4
28243	67	69.1	71.7	82.6	48	2 ½"	4
28244	76	78.6	81.1	94.4	49	3"	8
28246	108	110.9	113.8	132.1	65	4"	8

Installation Procedure



Step 1: Cut the tube

Use an appropriate rotary copper tube cutter to ensure a clean square cut.

Note: It is important that the copper tube is cut completely square, the end of the tube (outside) should be clean and free from any scratches or damage such as dints or deformity.



Step 2: Remove burrs

Make sure that the internal and external tube end is completely free from burrs or sharp edges by using a file and deburring tool.

Note: ensure over use does not affect the tube end outside diameter such as dints or deformity.



Step 3: Clean the tube end

Thoroughly clean the tube end using a cleaning pad in a rotating action. The tube end must be free from scratches, oxidation, dirt and debris.



Step 4: Inspect the fitting

Before inserting the tube, remove the dust cap and check O-Rings for correct placement, that they are free of damage, dust, dirt or debris. We recommend the fittings are retained in packaging up to the point of use wherever possible.



Step 5: Marking insertion depth on tube

All cut and deburred copper tube ends for insertion into the fitting require an insertion depth mark to be applied to the tube prior to insertion into the fitting. The mark will be applied by using a depth gauge ensuring the copper pipe fits comfortably within the right socket and using a marker pen to the required length. The mark will ensure the tube is inserted correctly into the fitting prior to press.



Step 6: Tube insertion

The Tube should be inserted parallel into the fitting coupling ensuring no damage is caused to the 'O' ring, ensuring the insertion mark is visible at the end of the fitting next to the fitting coupling end.



Step 7: Press tool selection

The tool to be used should be conformant, lubricated and maintained within its manufacturers service requirement. The correct jaw type and size should be selected and inspected to ensure it is clean and free from defects and contamination.

Note: Only approved tooling may be used on Brymec Press fittings. Refer to Approved Tooling Table on page 20 and 21.



Step 8: Press the joint

The jaw / sling should be placed over the fitting, aligned square and positioned to ensure jaw profile will press both the shoulder and O-ring. When all requirements are correct, the tool should be activated to press the joint. The tool should complete the full cycle and the jaw ends should fully close on completion. If the tool does not complete the full cycle during operation the fitting should be cut out and replaced with new fitting. No fitting should be pressed more than once. Please ensure any other manufacturers' documented requirements are met for your respective tool.



Step 9: Joint completion

The fitting should be inspected after pressing to ensure the correct press has been performed and no cracking or over deforming has occurred. The pipe insertion mark should be checked and be at the fitting edge, to ensure it has not moved. Any remains of the plastic foil ring can be removed so the fitting is left clean and visible as a completed joint.

Insertion marking length by size

Tube Size	Marking Insertion Depth
15mm	20±3 mm
22mm	22±3 mm
28mm	23±3 mm
35mm	25±3 mm
42mm	30±3 mm
54mm	36±3 mm
67mm	47±3 mm
76mm	51±3 mm
108mm	65±3 mm

➤ Brymec Training Programme

As part of our commitment to providing the highest standards of installation for each project we have developed and optimised the Copper Press Training Programme

This free of charge training package ensure that every aspect of press installation is covered from start to finish. This always proved popular and enjoyable, and includes the following:

- Academy Training in our Academy Training Centre
- Or On-Site Training
- Brymec 9 Step Press Installation Training
- Practical Demonstration by experienced Installation Trainers
- Comprehensive Assessment of each Trainee
- Certification for all Trainees who successfully complete the training, valid for 3 years
- Record of all Training Certificates

We recommend wherever possible that the Training is conducted in our Academy. As well as fantastic facilities, it has the added benefits of viewing our state-of-the-art facilities and Laboratory and meeting members of the Technical Team. It also provides the opportunity to inspect other many other contributing products such as Press Fit Valves and Support and Fixing items.

If On-Site training is required that can also be supported by our experienced trainers who will be happy to share great general good practice tips in addition to specific product training.

Please contact our sales team to request this; sales@brymec.com

WHY TRAINING IS NEEDED

Key reasons for training are:

- To ensure best practice installations
- To give uniformity of quality standards
- To save speed and cost on site
- To ensure the correct tooling is selected
- To prevent errors
- To validate our 25 Year Warranty



Brymec Technical Support

We recognise the importance of having top quality support from the manufacturer throughout every phase of the construction process, so we are here to provide assurance, technical support and assistance to safeguard your project.

Our Technical Team can assist you from Pre-construction right through to Post Contract and make sure that our attention to detail will be an asset for you.

Key Areas of Support

Specification

To ensure that our products suit the application in the best possible way we can offer advice or assistance at this stage

BIM Models

Our products are available in BIM Objects

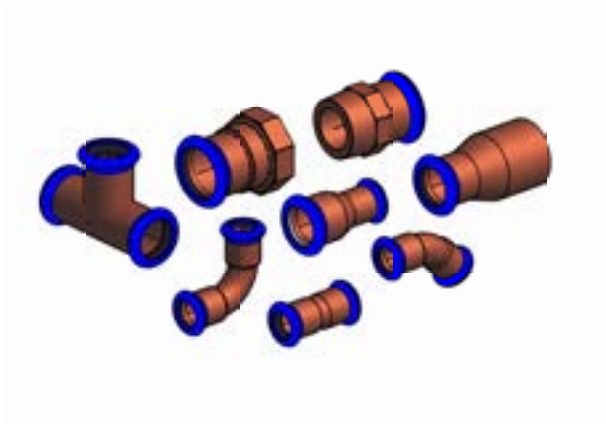

Project Support

This includes our excellent installation training, site attendance visits, verification and testing when required. Our Technical Laboratory provides quick results from all testing and analysis.

Post Contract

We can assist with full details for O & M Building Manuals, project information and records.

In-House Laboratory/Testing Facility

We have a purpose build laboratory to test our products to ensure they are of the utmost quality for your projects.



Warranty On Brymec Copper Press Fittings

At Brymec we place a huge emphasis on the quality of our range of branded products. To back this up, when using the Brymec copper press system with Type TX copper tube compliant with EN 1057, Brymec will provide warranty for the same period of the copper tube being used, up to a maximum of 25 years.

This is a maximum 25-year guarantee against faults caused by defective manufacturing of Brymec copper press fittings.

For full traceability all fittings are etched or stamped with unique branding and fitting size.

For the warranty to apply

1. Training

In order for the warranty to be valid each individual using the Brymec copper press system should be trained by an appropriate Brymec trainer. Upon successful completion of training, a certificate will be issued.

To arrange training please call **0333 000 55 55** or email sales@brymec.com

2. Tooling

Approved tools within manufacturer's service requirements, that are well maintained and used as per manufacturer's detailed requirements.

3. Tube

Tube must be Type TX conformant to EN 1057.

4. Environment

Brymec press must be installed in a suitable environment and be used for the correct application.

5. Installation

All Brymec press fittings to be installed in accordance with the Brymec press installation guidelines, and BS EN 806. All commissioning paperwork must be retained, including for extension / addition to any previously tested part of the system.

To view the full warranty terms and conditions visit brymec.com/warranty





Bailey Point

CASE STUDY

Brymec gains top marks for landmark university accommodation project

Brymec copper press and valve systems have been supplied, along with technical guidance, to equip the plant room of a 550 room student accommodation block with a robust, high-performance water supply system.

Bournemouth University is increasing its student intake and range of facilities as part of its BU2025 investment strategy. Brymec was appointed by mechanical and electrical engineers, William Coates, to supply product and technical expertise



Bailey Point is Bournemouth University's flagship student development, with its modern design, layout and facilities providing the new residents with the most communal space available on campus, including a roof terrace and free gym.

We have worked with William Coates on several projects and we were confident our close working relationship would allow us to deliver best-suited products and technical expertise to provide the most advantageous project solution within the tight timescales.

Jeremy Douglas

Specification Director, Brymec

on the construction of the landmark £31 million Bailey Point student accommodation development.

The modern student accommodation, located at the heart of the university's Lansdowne Campus, will home 550 students in clusters of ensuite bedroom apartments and studio flats, all served by full modern kitchen and communal areas.

The challenge facing the project consultants and contractors was to complete the development ready for a new intake of students to the university for the Autumn 2019 semester, placing the project on a strict schedule.

The unusual shape of the development site, within a constrained location, also had to be negotiated through the shrewd selection of products and systems that could adapt to the requirements of the project.

Brymec was selected to supply systems and provide technical expertise for the construction of the 14-storey building's primary plant room, which serves all 550 bedrooms and communal areas.

The Brymec Copper Press system of pipe fittings was selected to provide the on-site contractors with the ability to perform multiple aspects of the plant room install at the same time. The two-point press system on each fitting removes the need for more time-intensive jointing methods to be used.

In addition, Brymec Cast Iron Valves were used throughout the system installed by the William Coates team, while WRAS approved, full bore Brymec Lever Ball Valves were fitted to help the building facilities management team maintain and control the finished water supply system.



Throughout the duration of the project the onsite team at William Coates was able to liaise with Brymec's dedicated project manager to ensure the on-time delivery of components and products to Bailey Point as the development took shape.

The overall project was managed by specialist developer, McAleer & Rushe, with the topping out ceremony in February 2019.



Working with a partner that is easy to contact, easy to deal with and responsive is so important to the success of project like this. Throughout the build of the plant room we were impressed by the quality of the products and materials supplied by the Brymec team.

The delivery plan put in place worked very well, ensuring my team could continue to meet its deadlines throughout the project.

"I've enjoyed working with the Brymec team, and knowing that if there was an issue there was an available point of contact there to solve it provided great reassurance.

Dominic McGuigan

Site Engineer, William Coates



➤ Re-Gen Ernest Dence

CASE STUDY

Brymec supports Re-Gen M&E on Ernest Dence Estate heating system upgrade

Brymec is supporting M&E specialist Re-Gen to deliver a new heat pump heating system and energy-saving upgrades to residents at the Ernest Dence Estate in the Royal Borough of Greenwich.

The council has set a target of net-zero carbon emissions by 2030 (twenty years ahead of the UK national target). As part of this strategy, the Ernest Dence estate refurbishment project includes the installation of a new communal heating system based on a state-of-the-art water source heat pump. The 95 homes on the estate will also have other improvements such as extra loft insulation, new heating controls, and updated windows.

Brymec's ability to ensure timely deliveries to the site was particularly important because residents remained in their homes while Re-Gen's team carried out the work. Re-Gen Contracts Manager, Gary Beacon says: "Guaranteed next-day a.m. deliveries were essential when working on occupied residential installations, something that we can rely on Brymec to fulfill."

The project poses several challenges that Re-Gen has addressed, including the fact that the Ernest Dence social housing estate, situated near the south bank of the Thames, was built between 1933 and 1938 (during the works, a previously undocumented World War Two bomb shelter was uncovered).

Much of the heating plant and equipment in the building was over 25 years old and beyond economical repair. This included the existing heating, hot water, and cold-water services for residents, which were also over 30 years old, with water cylinders under-sized for modern use.

Brymec supplied a range of products to Re-Gen as its team worked on the project, including the Brymec copper press-fit system for water or gas. This has been designed to make installation easier and safer, with an easy-to-use press indicator system that's also backed up by a built-in leak detector, providing extra system protection. Other products supplied by Brymec included phenolic blocks, valves and cold-water meters.

Gary adds that working with the Brymec team meant they received great support: "We have built up a good relationship with our local branch, and we know we can depend on excellent service and competitive prices."



We are delighted that we have been able to play our part in delivering this important refurbishment project in Greenwich. It is important to our team to know that we are helping our clients overcome challenges by providing dependable and reliable service and high-quality products.

Jake Harvey

Brymec

The upgraded heating and hot water system installed by Re-Gen will not only ensure greater comfort for Ernest Dence residents, but the heat pump technology will also deliver more than 5,000 tonnes of CO₂e savings over 25 years.

Terms of Business

1. BACKGROUND

1.1 These Terms apply to the Contract between Brymec and the Customer for the sale of Brymec Products. Any other terms, whether implied by custom or practice, or which the Customer may seek to include, are specifically excluded.

1.2 Capitalised words (such as 'Contract'), have a specific meaning which is set out in 10 below.

2. CONTRACT TO BUY PRODUCTS

2.1 The Products are described on Brymec's website and in its catalogue. Specifications for Products are subject to change, in which case, Brymec will endeavour to supply an equivalent or suitable alternative.

2.2 When the Customer wishes to place an order for Products, it will provide a purchase order to Brymec. If Brymec accepts such order, it will issue an Order Acceptance to the Customer, at which point the Contract shall come into existence.

2.3 The Customer is responsible for ensuring that the details in the Order Acceptance are complete and accurate.

3. DELIVERY

3.1 Each delivery of the Products will be accompanied by a delivery note that shows the date of the Order Acceptance, the relevant Brymec reference number, and the type and quantity of the Products.

3.2 Brymec shall deliver the Products to the Delivery Location at any time after Brymec notifies the Customer that the Products are ready.

3.3 Delivery is completed on the completion of unloading of the Products at the Delivery Location (and, if applicable, Signed For.)

3.4 Customer must notify any issues of non-delivery, discrepancy or damage to Brymec within 2 business days of Delivery (see further 4.2 below).

3.5 Any dates quoted for delivery are approximate only, and the time of delivery is not of the essence. Brymec shall use all reasonable commercial efforts to meet any specific delivery dates. However, Brymec will not be liable for any delay in delivery of the Products.

3.6 If Brymec fails or is unable to deliver the Products for any reason (except for an Unforeseen Event), its liability shall be limited to the costs and expenses incurred by the Customer in obtaining replacement Products of similar description and quality in the cheapest market available, less the price of the Products. Brymec shall have no liability for any failure to deliver the Products to the extent that such failure is caused

by an Unforeseen Event, or the Customer's failure to provide Brymec with adequate delivery instructions or any other instructions that are relevant to the supply of the Products.

3.7 Brymec may deliver the Products by instalments, which shall be invoiced and paid for separately. Any delay in delivery or defect in an instalment shall not entitle the Customer to cancel any other instalment.

4. QUALITY

4.1 Brymec warrants that, on delivery, the Products shall conform in all material respects with their description and any applicable Specification. For products sold by weight, or in the manufacturer's packaging, Brymec may supply quantities of up to 5% more or less than the amount ordered.

4.2 Subject to 4.3 and 4.4 below, if i) the Customer gives notice in writing to Brymec within 2 business days of delivery that the Products do not comply with the Specification, and ii) Brymec is given a reasonable opportunity to examine such Products, and iii) the Customer returns such Products to Brymec's place of business at the Customer's cost, Brymec shall, at its option, replace the defective Products or refund the price of the defective Products in full.

4.3 Brymec shall not be liable for the Products' failure to comply with the warranty set out in clause 4.1 if: i) the Customer makes any further use of such Products after giving notice under 4.2 above; ii) the defect arises because the Customer failed to follow good trade practice or instructions as to the storage, commissioning, installation or use of the Products; or iii) the Customer alters or attempts to repair such Products.

4.4 Brymec may accept Product returned to it no later than 10 business days after the date of Delivery for credit or exchange, provided that the correct delivery details are provided. In this case, Brymec may make a charge for handling and restocking equal to 25% of the price of the returned Products.

4.5 Non-stock Products purchased by Brymec at the Customer's request are non-returnable and non-refundable.

4.6 Other than as set out above, Brymec shall have no liability to the Customer in respect of the Products' failure to comply with the warranty set out in clause 4.1.

5. TITLE AND RISK

5.1 The risk in the Products shall pass to the Customer on completion of delivery.

5.2 Title to the Products shall not pass to the Customer until the earlier of: i) Brymec receives payment in full for the Products; and ii) the Customer resells the Products, in which

case title to the Products shall pass to the Customer at the time specified in 5.4 below.

5.3 Until title to the Products has passed to the Customer, the Customer shall store the Products separately from all other products held by the Customer so that they remain readily identifiable as Brymec's property, maintain the Products in satisfactory condition, and keep them insured against all risks for their full price from the date of delivery.

5.4 The Customer may use or resell the Products before Brymec receives payment for the Products, in which case it does so as principal and not as Brymec's agent, and title to the Products shall pass from Brymec to the Customer immediately before the time at which such reuse or resale by the Customer occurs.

6. PRICE AND PAYMENT

6.1 The price of the Products shall be the price set out in the Order Acceptance issued by Brymec. Brymec may, by giving notice to the Customer at any time up to delivery, increase the price of the Products to reflect any increase in the cost of the Products that is due to i) any factor beyond Brymec's control (including foreign exchange fluctuations, increases in taxes and duties, and increases in labour, materials and other manufacturing costs), or ii) any request by the Customer to change the delivery date(s), quantities or types of Products ordered, or the Specification.

6.2 The price of the Products excludes amounts in respect of value added tax (VAT), which the Customer shall additionally be liable to pay.

6.3 Unless otherwise stated on the Order Acceptance, Brymec shall be responsible for the cost of insurance and transport of the Products to the Delivery Location.

6.4 Brymec may invoice the Customer for the Products on or at any time after the Products have been despatched.

6.5 Unless otherwise stated in the Order Acceptance, the Customer shall pay the invoice in full and in cleared funds by the end of the month following the month the invoice was dated to the bank account nominated by Brymec. Time for payment is of the essence.

6.6 The Customer must raise any invoice queries with Brymec by email to creditcontrol@brymec.com within 28 days of the invoice date. Brymec will endeavour to respond within 2 business days and to propose a resolution to the Customer within 3 working days. The Customer must communicate any non-acceptance of such resolution to Brymec within 3 business days, failing which the relevant invoice remains payable according to these Terms.

6.7 If the Customer fails to make any payment due to Brymec under the Contract by the due date for payment, then Brymec

shall be entitled to charge interest on the overdue amount at the rate of 4.0% per annum above the base rate from time to time of the Bank of England. Such interest shall accrue on a daily basis from the due date until actual payment of the overdue amount, whether before or after judgment. The Customer shall pay the interest together with the overdue amount.

6.8 The Customer shall pay all amounts due under the Contract in full without any set-off, counterclaim or deduction. Brymec may set off any amount owing to it by the Customer against any amount payable by Brymec to the Customer.

7. LIMITATION OF LIABILITY AND INSURANCE

7.1 Nothing in these Terms shall limit or exclude Brymec's liability for: (i) death or personal injury caused by its negligence; ii) fraud or fraudulent misrepresentation; iii) breach of the terms implied by section 12 of the Sale of Products Act 1979; or defective products under the Consumer Protection Act 1987.

7.2 Subject to 7.1 above, Brymec shall under no circumstances whatsoever be liable to the Customer, whether in contract, tort (including negligence), breach of statutory duty, or otherwise, for any loss of profit, or any indirect or consequential loss arising under or in connection with the Contract; and

7.3 Brymec has obtained insurance cover in respect of its own legal liability for individual claims not exceeding £1,000,000 per claim. Therefore Brymec's total liability to the Customer in respect of all other losses arising under or in connection with the Contract, whether in contract, tort (including negligence), breach of statutory duty, or otherwise, shall in no circumstances exceed £1,000,000, and the Customer is responsible for making its own arrangements for the insurance of any excess loss.

8. UNFORESEEN EVENTS

8.1 Neither party shall be in breach of this Contract nor liable for delay in performing, or failure to perform, any of its obligations under this Contract if such delay or failure results from an Unforeseen Event. If the period of delay or non-performance continues for three months, the party not affected may terminate this Contract by giving one month's written notice to the affected party.

9. GENERAL

9.1 Assignment. The Customer may not assign, transfer, mortgage, charge, subcontract or deal in any other manner with any or all of its rights or obligations under the Contract without Brymec's prior written consent.

9.2 Confidentiality. Each party undertakes that it shall not at any time during this agreement, and for a period of 5 years after termination of this agreement, disclose to any person any confidential information concerning the business, affairs,

customers, clients or suppliers of the other party, except as permitted by this paragraph. Each party may disclose the other party's confidential information: (i) to its employees, officers, representatives or advisers who need to know such information for the purposes of carrying out its obligations under or in connection with the Contract; and (ii) as may be required by law. No party shall use any other party's confidential information for any purpose other than to exercise its rights and perform its obligations under or in connection with this agreement.

9.3 Entire agreement. This Contract constitutes the entire agreement between the parties and supersedes and extinguishes all previous agreements and understandings between them, whether written or oral, relating to its subject matter. Each party agrees that it shall have no remedies in respect of any statement, representation, assurance or warranty (whether made innocently or negligently) that is not set out in this agreement.

9.4 Variation. No variation of this Contract shall be effective unless it is in writing and signed by the parties (or their authorised representatives).

9.5 Third party rights. No one other than a party to this Contract shall have any right to enforce any of its terms.

9.6 Law and jurisdiction. The Contract, and any dispute or claim arising out of or in connection with it shall be governed by and construed in accordance with the law of England and Wales. Each party agrees that the courts of England and Wales shall have exclusive jurisdiction to settle any dispute or claim arising out of or in connection with this Contract.

10. DEFINITIONS:

10.1 Brymec: Brymec Limited, whose registered office is at Unit C, Redlands, Coulsdon, Surrey, CR5 2HT.

10.2 Terms: the terms set out in this document.

10.3 Contract: the contract between Brymec and the Customer for the sale and purchase of the Products in accordance with these Terms.

10.4 Customer: the business or person who purchases the Products from Brymec.

10.5 Delivery Location: the location for delivery of the Products set out in the Order Acceptance, or such other location as the parties may agree.

10.6 Order Acceptance: a form issued by Brymec in response to a Customer's order for Products, specifying Product details, quantities, prices and costs of transportation.

10.7 Products: the products (or any part of them) set out in the Order Acceptance.

10.8 Signed For: a Customer requirement stated in the Order Acceptance that a delivery of Product must be signed for at the Delivery Location.

10.9 Specification: any specification for the Products set out on Brymec's website or in its catalogue.

10.10 Unforeseen Event: an event or circumstance beyond a party's reasonable control.



Quality Policy

Brymec Ltd (the 'Organisation') aims to provide defect free products and services to its customer on time and within budget.

The Organisation operates a Quality Management System that has gained BS EN ISO 9001 : 2015 certification, including aspects specific to the stockholding and supply of mechanical, plumbing and air conditioning products and services.

This gives us a platform to guarantee a structured approach to our continuous improvement cycle, and ensure we continue to meet and exceed the following key goals:

- Excellence of service to our customers, delivering on site, in full, on time; in the relentless pursuit of total customer satisfaction.
- Offering quality products and systems. We work with worldwide manufacturing plants (in line with our social and ethical policy) to source the best products for the UK market. We ensure that the products are fit for purpose and comply with the relevant approvals and standards. We also research and develop innovative solutions which will add value to our customers, developers and end users
- To motivate, engage and continuously develop our team by providing training, coaching, knowledge sharing and investment to ensure their absolute competence.
- To continue to invest in technology, working to understand customers' needs and streamline their buying processes to maximise efficiencies via modern technology.

This quality policy is endorsed and regularly reviewed by our Senior Management Team, and its scope is communicated to all Brymec employees via our website and other appropriate methods.

Our vision is to become an essential and indispensable supplier to the Building Services Contractor by providing excellence of service, quality products and continually investing in technology.

In order to achieve our vision, we ensure Brymec is an organisation where people love to work, upholding our core values of excellence, courage and collaboration to actively engage our team in contributing towards providing the highest level of customer satisfaction.

Luke Reiner

Managing Director

➤ Ethical Global Procurement Policy

ETHICAL POLICY - SOURCING

At Brymec we recognise the importance of credibility, integrity and trustworthiness in our success as a business. We are committed to upholding high ethical standards in all our operations, everywhere in the world. We believe in the principles of honesty, fairness, and respect for individual and community freedoms. The ethics of our UK operations are demonstrated through responsible:

- Business processes
- Corporate governance
- Custom and practice
- Quality management
- Safe working practices
- Corporate social responsibility
- Facility management
- Equality and diversity
- Anti-bribery and corruption
- Employee care

The Ethical Trading Initiative Code forms the basis of this policy

Additionally, as we expand our network of suppliers to source products globally, it is increasingly necessary to ensure that the organisations that we undertake business with also meet our expectations of standards of supply.

As a minimum Brymec Ltd expects its supply partners to comply with all local laws and regulations and to respect internationally recognised human and labour rights as well as international initiatives for climate change.

In particular we require that suppliers ensure:

- Working hours and remuneration are reasonable and meet the required local wage and working time laws
- Working conditions are safe and hygienic
- No discrimination is practised
- Employment is freely chosen
- Children are not employed, and local minimum age rules are in place
- Freedom of Association and the right to collective bargaining are respected
- No improper advantage, including the payment of bribes.
- Packaging and waste are subject to recycling and safe disposal guidelines
- That all sourcing of materials and manufacturing processes are subject to sustainability and renewability rules

Brymec carry out initial assessments and, on agreeing terms of business, provide the criteria against which the company has been measured by way of regulating ongoing requirements.

Brymec then carry out periodic on-site audits to ensure that compliance is maintained.

Brymec will work with its suppliers to guide and advise them in maintaining and improving required levels of environmental standards.

The Brymec Sourcing Director has responsibility for this policy and will report to the management meetings on any issues arising.

A copy of the Full Ethical trading initiative can be found at www.ethicaltrade.org.



Notes

Lined area for taking notes, consisting of multiple horizontal dashed lines.

Brymec 

www.brymec.com

0333 000 55 55