



Brymec 

**HDPE Drainage
Technical Manual 2023**



Contents

Introduction to Brymec	4
Environmental Model	5
Brymec HDPE Drainage System	6
Key Features and Advantages	8
Technical Information	10
Quality Standards	10
Applications and Technical Data	10
Technical Specification	11
Pipe Dimensions	11
Expansion Calculations	12
Expansion Allowance	14
Fire Stopping	17
Pipe Support Centres	20
Tooling and Equipment	21
Testing Procedures	22
Product Range	23
HDPE Items	24
Pipe Clamps	40
Fire Stop Products	41
Installation	42
Site Storage	44
Brymec Technical Support	46
Warranty	47
Case Studies	49
General Information	51-55



➤ Introducing Brymec Products

Our philosophy has always been to provide the ultimate convenience and peace of mind to our clients. This also includes ensuring that you have the best possible products to select from.

By investing in innovation, we have been able to engineer our own range of products, all manufactured to our exacting specifications to deliver quality solutions for the Building Services Industry.

Every one of our Brymec products is manufactured to the highest quality standards possible and are backed up by our in-house technical support, robust quality controls and industry-leading guarantees.

Our innovative approach simplifies your supply chain, giving you direct access to the manufacturer. This gives you greater control and confidence in Brymec being the right partner for you.

With almost 50 years of experience, we understand the challenges you face and the solutions you require.

This complete understanding of industry products and systems enable us to collaborate with you more effectively and efficiently, to deliver a more comprehensive range of products that are specific to your needs.



➤ Our 3 Step Approach to an Environmentally Friendly Build...

Brymec cuts down the movement of products, which cuts the impact to the environment

This helps our customers reduce their carbon footprint of the products they buy from us

Traditional 6 Step Model

- | | | |
|---------------------------------|-------------------------|---------------------|
| ➊ Manufacturer | ➋ European Distribution | ➌ UK Distribution |
| ➍ Merchant Central Distribution | ➎ Branches | ➏ Construction Site |

Our Environmentally Friendly Business Model



Brymec HDPE Drainage System

The use of HDPE (High Density Polyethylene) as a strong, lightweight and economical plastic pipework material began in the late 1950's, and due to excellent characteristics of elasticity and resistance to mechanical stress, it has proved increasingly popular for soil and waste applications in commercial building drainage ever since.

Brymec have almost 50 years of industry experience supplying the Mechanical and Plumbing sector of the construction market and have used this to develop and grow our range of HDPE Drainage as an important part of our commercial drainage provision.

Utilising our unique strengths in manufacturing and technical excellence, we have used the knowledge that we have gained over this period of working with Engineers, Designers and Installers to make sure our HDPE system will meet the most stringent demands of your projects.

Our Commercial Grade HDPE has been designed and manufactured to deliver optimum quality, performance, efficiency and durability to enable the highest quality standards for your installation. Our system is manufactured in accordance with the latest industry standards and requirements.

The excellent physical properties of HDPE make it lightweight, strong, and chemical resistant (suitable for clinical and industrial waste). It is manufactured to EN1519, and is suitable for temperatures from -40°C to 95°C

Our track record of successful projects range from vital fast track projects to use on some of the most prestigious buildings in the UK, and are evidence that Brymec HDPE Drainage is the product of choice for your projects.



Key Features and Advantages

The Brymec HDPE Drainage System has several key advantages

With our technical support, vast stockholding, and attention to detail our system will provide the user with the easiest and most reliable installation option. This is coupled with best practice standards from the start of manufacture to the completion of a project.

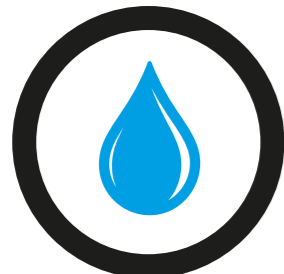

LEAKPROOF

HDPE can be easily and safely jointed by either Butt Welding or Electro-Fusion Coupler methods.



IMPACT RESISTANCE

An important characteristic is the high strength of HDPE which provides excellent impact resistance during transport, installation and once the system is in use even in low temperatures.

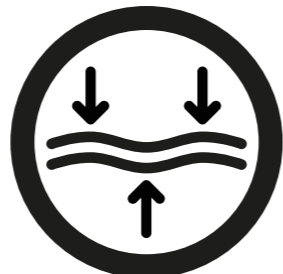

FLEXIBILITY

Exceptional elasticity and flexibility will provide resistance to mechanical stress and vibrations, and also resists damage from ice in sub-zero temperatures.

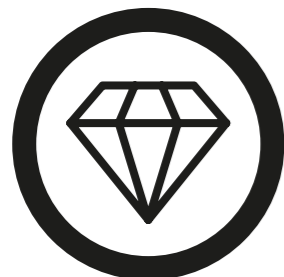

DURABILITY

HDPE is recognised as a durable and stable material with an expected lifespan in normal conditions of more than 50 years.



EASY INSTALLATION

Despite high strength, HDPE is lightweight which assists with speed and safety during transport and handling during construction.

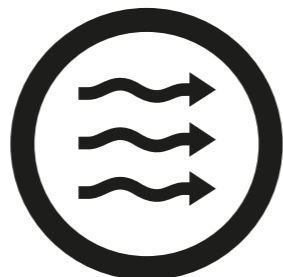

BLOCKAGE RESISTANCE

The smooth and abrasion resistant surface finish reduces the formation of deposits and encrustations which reduces the risk of blockages, lowers maintenance requirements and also provides good flow characteristics.

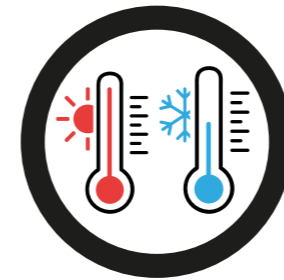

WIDE TEMPERATURE RANGE

HDPE will keep its characteristics even at low temperatures, and it will not deform or become brittle. The wide range of operating temperatures between -40°C to +70°C continuously (also suitable for intermittent peak loads of +95°C for up to 2 minutes) suits most building environments.



CHEMICAL RESISTANCE

This is resistant to most chemicals and will withstand organic and inorganic solvents. At 20°C it is resistant to most household detergents that may be used for sinks and WC's.



WEATHER RESISTANCE

The system is impervious to the weather.



UV RESISTANCE

Due to the content of black carbon, HDPE is UV resistant to photo-oxygenation processes caused by UV rays.

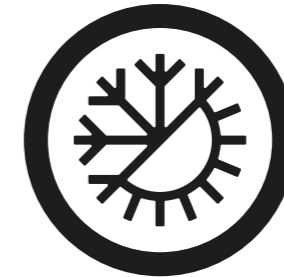

LOW THERMAL CONDUCTIVITY

The formation of condensation is minimised due to the low thermal conductivity.



COST EFFECTIVE

The system is suitable for the most challenging commercial products yet is cost effective due to the ease and speed of installation and the economy of production.

Installation Advantages;



BUTT WELD OR ELECTRO FUSION COUPLING

Our fittings and pipe can be joined with either Electro Fusion Couplers or by Butt Welding methods.



DUAL FUSION RING ON LARGE COUPLERS

We ensure the easiest and safest method of jointing 200mm, 250mm and 315mm Electro Fusion Couplers. We supply our couplers with a dual fusion ring, enabling the couplers to be installed one side at a time, greatly assisting the installation of heavier items.



LONG SPIGOT FITTINGS FOR ELECTRO FUSION COUPLERS

To enable installation with Electro Fusion (remove hyphen) Couplers we have a range of fittings with extended spigots so that either Couplers or Butt Welding can be used to form secure and quick connections. This is particularly beneficial when installing elements that have been pre-assembled off site.

Technical Information

Quality Standards

Brymec HDPE is manufactured to the highest quality standards.

Our HDPE Pipe and Fittings have been carefully designed and manufactured to meet the most stringent quality standards. Products undergo stringent testing in compliance with our ISO 9001:2015 Quality Management System.

Products are made to the following standards:

- › EN1519-1
- › ISO/TR 10358
- › EN13501

Applications & Technical Data

Application	Internal Installations	Pressure	Temp. (°C)
Soil and Waste water	Suitable for sanitary and domestic waste water, HDPE can also be embedded in concrete with certain precautions.	1.0 Bar	Up to 95
Roof Drainage	Suitable for rainwater and surface water	1.0 Bar	Up to 95
Syphonic Drainage	Please contact Brymec	1.0 Bar	Up to 95
Clinical Waste	Compatible with most drainage requirements in schools, laboratories and industrial plants according to ISO/TR 10358	1.0 Bar	Up to 95
Industrial Waste	Compatible with most drainage requirements in schools, laboratories and industrial plants according to ISO/TR 10358	1.0 Bar	Up to 95

Not suitable for waste water containing petrol or Benzene (DIN 1986/3, 2.3)

Technical Specification

Physical Property	Value	Unit of Measure	Test Methods
Temperature Range	-40 to +70 Continuous,+ 95 intermittent >2 Mins	° C	
Pressure Rating	1.0 Bar	Bar	EN 1519-1
Fire Classification	B2		DIN4102
	Euroclass E		WN 13501-1
Density	954	kg/m3	ISO 1183 D
Melt Index 190 DgeC/5kg	0.5	g/10Min	ISO 1133 Cond. 18
Carbon Black Content	2.0 +/- 2.5	%	ASTM D 1603
Tensile Strength	>20	Mpa	ISO/DIS 6259
Elongation at Break	>600	%	ISO/DIS 6259
Coefficient of linear expansion	0.20	mm/m DegC	ASTM D 696
Modulus of Elasticity	1000	MPa	

Pipe Dimensions

Ø External (mm)	Ø Internal (mm)	Minimum Thickness (mm)	Pipe Bore (cm ²)
32	26	3	5.3
40	34	3	9
50	44	3	15.2
56	50	3	19.2
63	57	3	25.4
75	69	3	37.3
90	83	3.5	54.1
110	101.4	4.3	80.7
125	115.2	4.9	104.2
160	147.6	6.2	171.1
200	187.6	7.7	276.4
250	234.4	9.6	431.5
315	295.4	12.1	685.3

Expansion Calculations

Change in length

When subjected to temperature variations the dimensions of Brymec HDPE are subject to change in length. This change in length should be borne in mind during design of the installation. Expansion contraction can be calculated and allowed for. These changes in length are, for the temperatures in question, proportional to the thermal difference the material is subjected, as an expression of the relation: $\Delta L = \alpha L \Delta T$

Where:

ΔL = change in length in mm

α = linear expansion coefficient 0.2 mm/m/°C

ΔT = thermal difference °C

L = initial pipe length in m

The temperature difference (ΔT) is given by the difference in temperature during the mounting phase (T_i) and the maximum or minimum temperature achieved during operation.

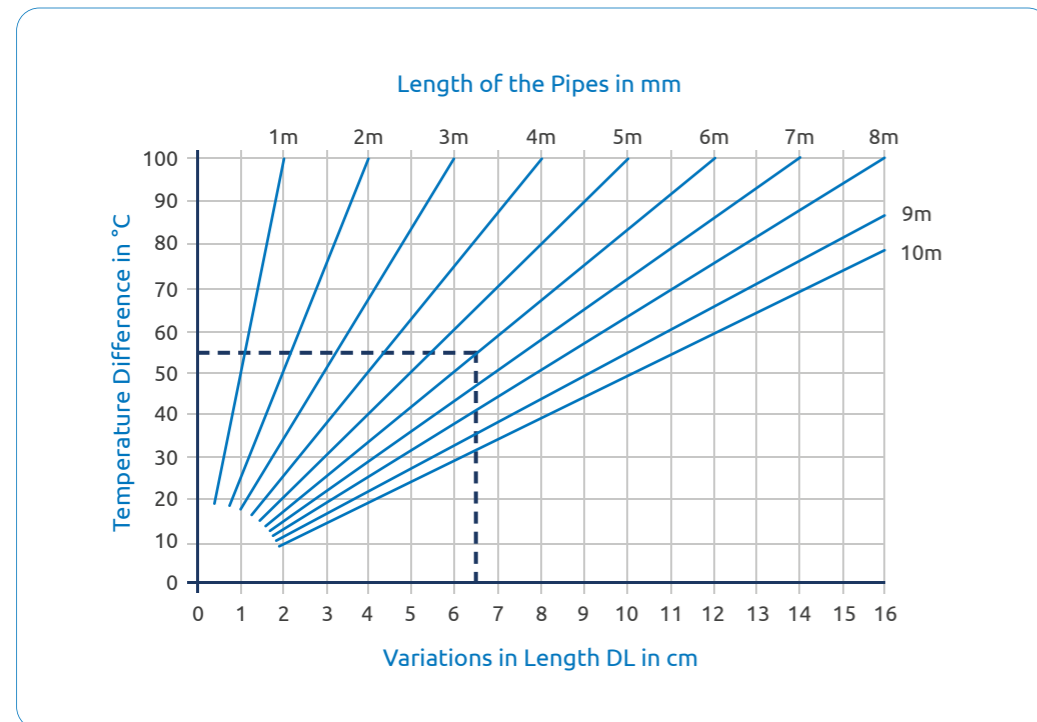

The temperature can depend on:

- > Variations in the external temperature (T_e)
- > The temperature (T_f) of the fluid flowing in the pipes

Expansion Calculations

Change in length (continued)

However, in this second case, the value taken is not always the fluid's T_f but a T_c value reduced by about 10 - 20°C. That is because extreme operating conditions last for a short time, while poor thermal conductivity of polyethylene does not permit the pipe to reach the temperature of the fluid.

Examples of calculations

a) Pipes subjected to increasing temperature:

T_f = fluid temperature 95°C

T_c = maximum reduced operating temperature 75°C

T_i = initial pipe temperature 20°C

$\Delta T = 75 - 20 = 55^\circ\text{C}$

L = length of the pipes 6m

$\Delta L = 6 * 0,2 * 55 = 66\text{mm (expansion)}$

b) Pipes subjected to decreasing temperature:

T_f = minimum operating temperature -10°C

T_i = initial pipe temperature 20°C

$\Delta T = 20 - (-10) = 30^\circ\text{C}$

ΔL = length of the pipes 6m

$\Delta L = 6 * 0,2 * 30 = 36\text{mm (contraction)}$



Expansion Allowance

Compensation of changes in length of pipes

Expansion compensators

To prevent pipes from being subjected to mechanical stresses (axial thrusts), they must be able to change in length freely. This can be achieved by using:

a) Systems that use the elasticity and inflection of some sections of pipe in the system.

With this device, the change in length is compensated by the elastic deformation which may affect some sections of the pipes in the system. It is particularly advantageous when the geometric configuration of the system, with suitably positioned fastenings, allows the exploitation of the material's elasticity.

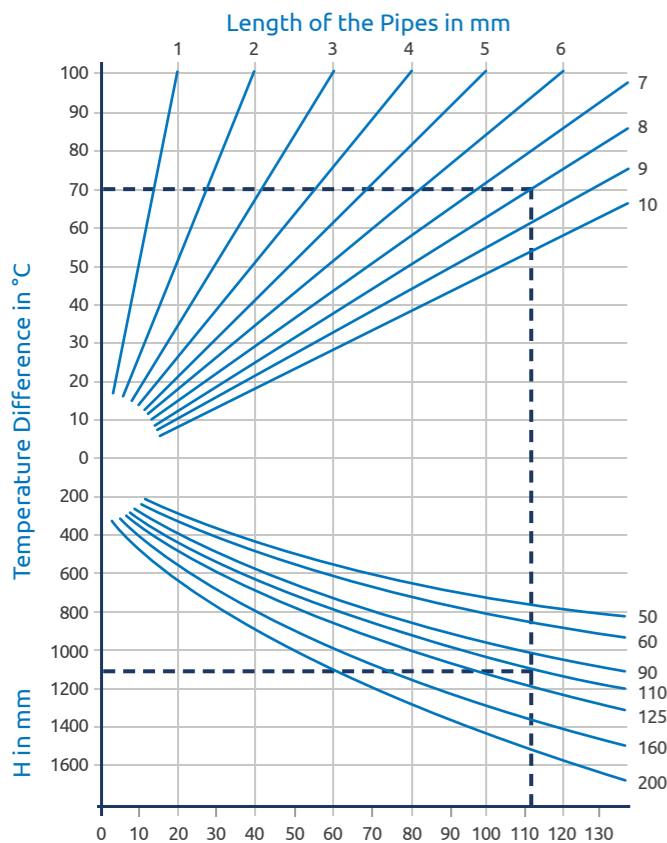

Calculation of the thermal expansion and the length of the expansion fusion for Brymec HDPE pipes.

The length "H" of the pipe section subjected to inflection is given by:

$$H = 10 \cdot \sqrt{\Delta L \cdot D}$$

- ΔL is the change in length that needs to be compensated
- D is the diameter of the pipe

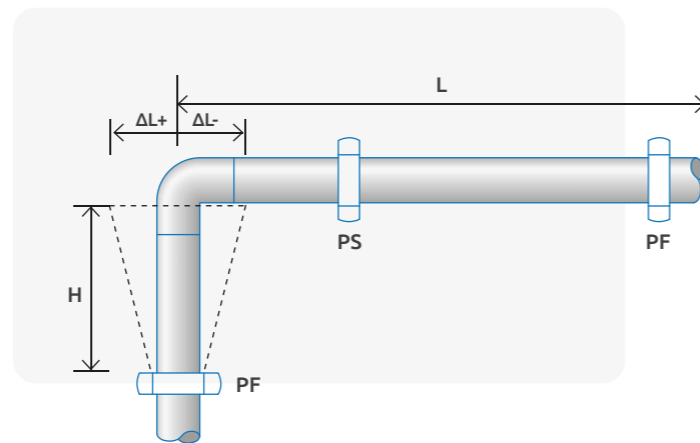

Expansion Allowance

Compensation of changes in length of pipes (continued)

b) Expansion sleeves or joints

Devices with seats where the free end of a pipe can slide to compensate for its change in length.

The expansion sleeve is used for:

- Vertical drain pipes (see Fig. A)
- Horizontal collectors/dorsals (see Fig. B on next page)

To install the expansion sleeve properly, it is necessary to take into account the following parameters:

- Length of the pipe
- Maximum temperature range the pipe is subjected (ΔT)

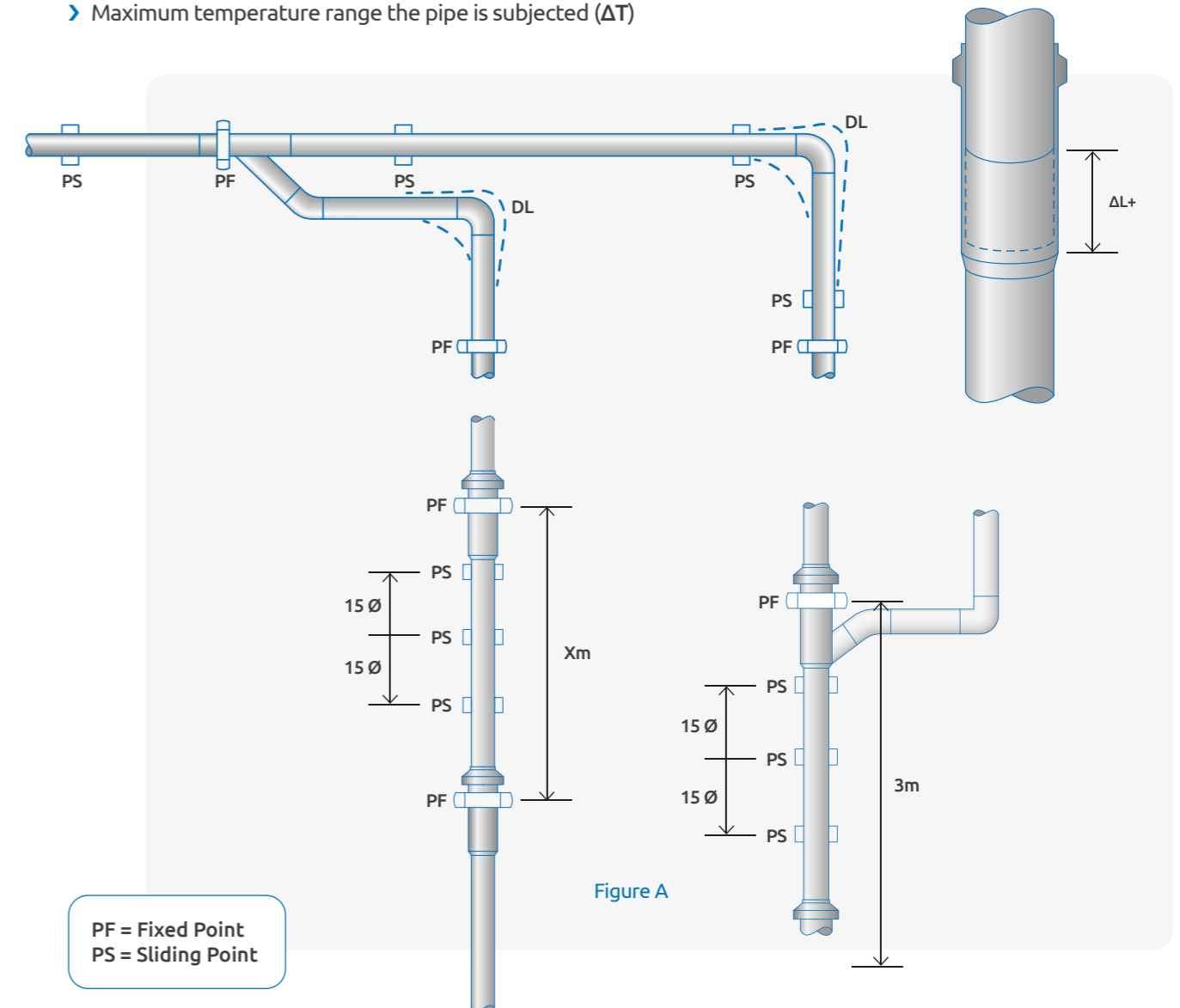

PF = Fixed Point
PS = Sliding Point

Figure A

Expansion Allowance

It is assumed that changes in pipe length take place according to design provisions for the expansion sleeve to work properly. Therefore, it is necessary to strictly constrain the ends of the pipe demanded for compensation in a way that movements in the direction of the installed compensation devices are allowed. These constraints are the fixed points in the system.

They are selected and positioned according to the system's construction characteristics, structural conditions, branches, passing through structures, etc., which may constitute fixed points themselves. To create fixed points, metal supports are normally used, including:

- Collar to support and fasten the pipes or the expansion sleeve
- Rod
- Anchor plate
- Screws or bolts.

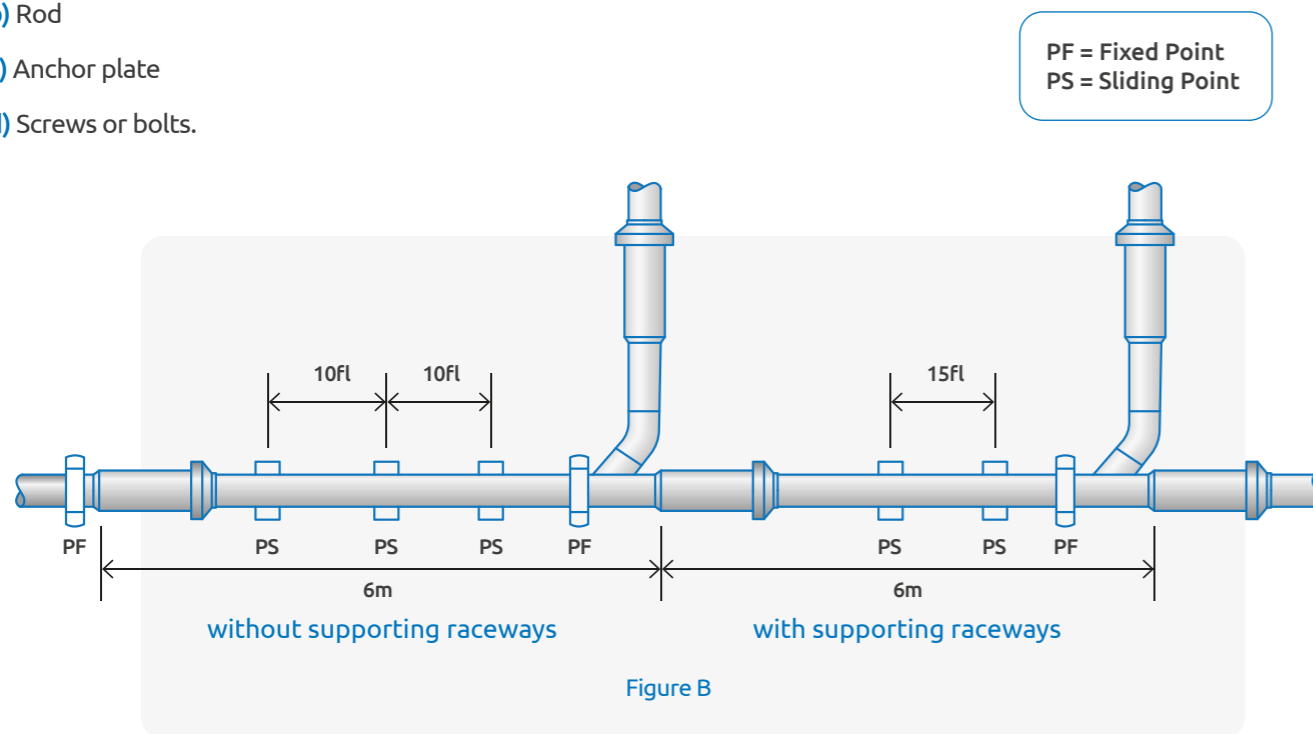

Creation of fixed points

Thrusts

The forces that fixed points are subjected to are:

P = thrust exercised by the pipe

p = weight of the pipe and the liquid contained therein.

In the case of expansion sleeves, the force is represented by the reaction offered by the sleeve to the sliding of the pipe in its seat. In the case of dilators, it is represented by the resistance of the pipe section subjected to elastic deformation and is obtainable from relations such as: $P = n \cdot \Delta L \cdot E J / H^3$

Design Considerations - Fire Stop

Fire Protection

The fireproof sleeve is the essential accessory against the spreading of fire and smoke. Due to its characteristics and depending on the type of drainage system, it provides protection classified as REI 120 or REI 180.

This means that when subjected to fire, the collar maintains its mechanical characteristics and stops the spreading of flames of up to 180 minutes.

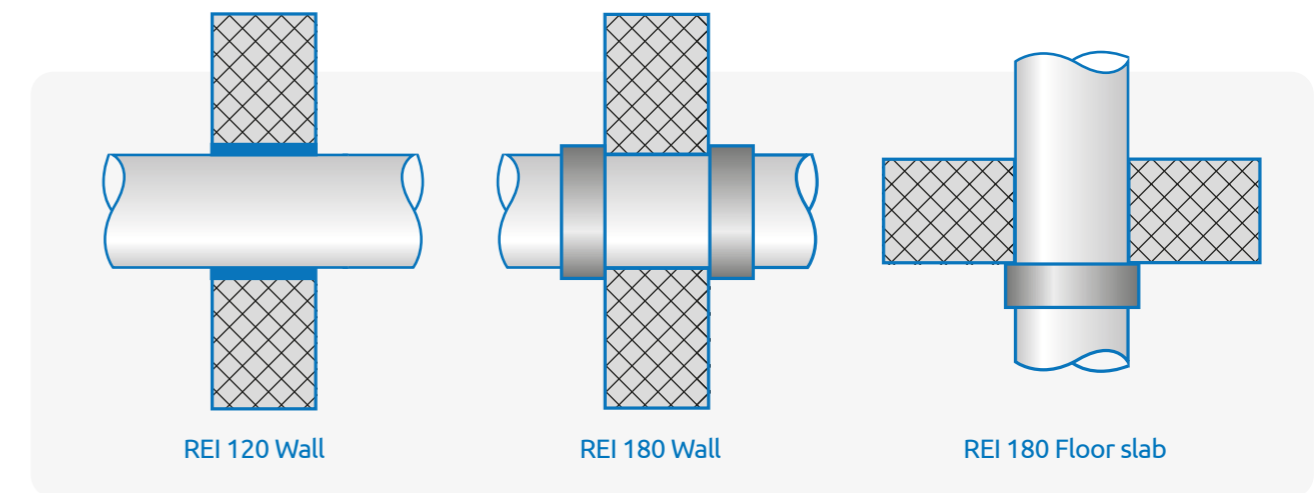

The sleeve includes a metal bracket, which acts as container for a ring made of intumescent thermo-expanding material, that reacts to high temperatures. In case of fire, the sleeve ring expands, closing the pipe passage and isolating the connection between the environments.

Operation of the fireproof sleeve

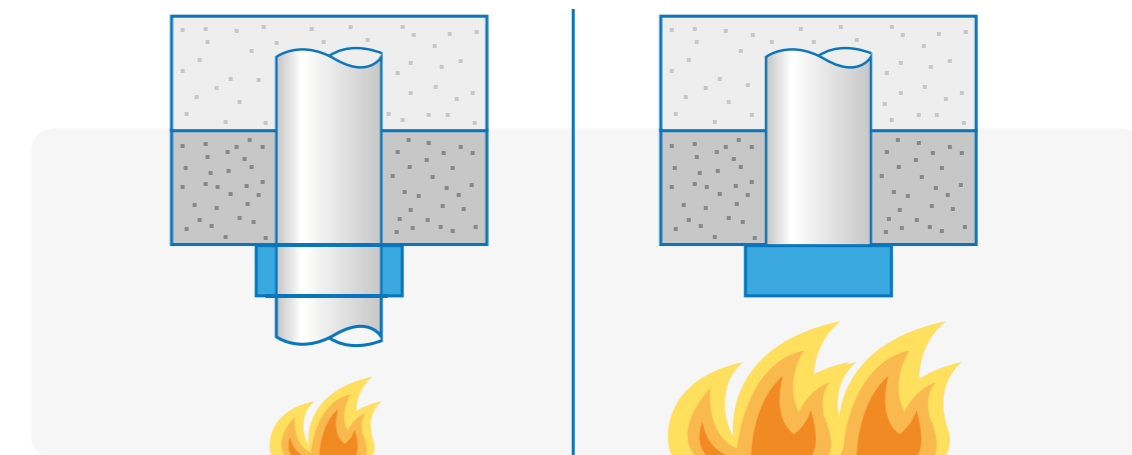

► Installation Instructions - Fire stop

Installation of fireproof sleeve

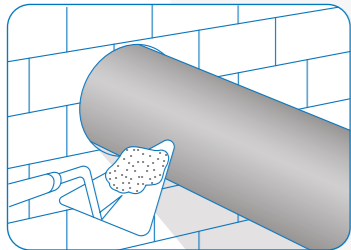

1. Seal cracks around the pipe using grout.

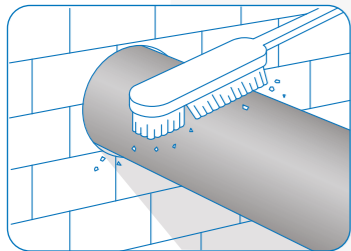

2. Clean the pipe before applying the fireproof sleeve.

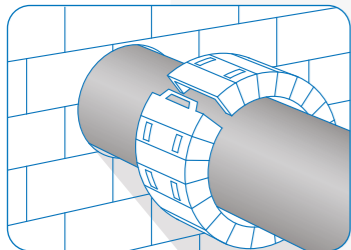

3. Fasten the sleeve to the pipe.

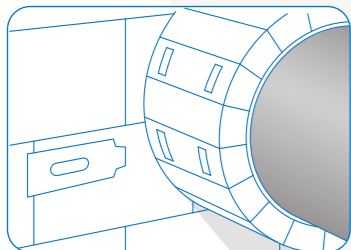

4. Fasten the hooks into the special holes around the fireproof sleeve.

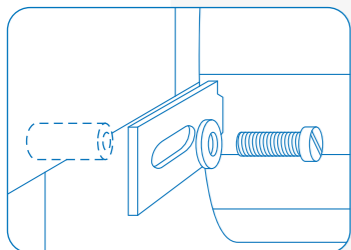

5. Use metal plates and anchor to fasten the sleeve



➤ Pipe Support Centres

Bracketing Support Centres for systems using Expansion Sockets

External Diameter OD (mm)	Maximum Bracket spacing along the pipe run L1 (m)		Maximum bracket spacing before Expansion Socket L1 (m)		Maximum spacing between Expansion Sockets L2 (m)
	Horizontal pipes ⁽¹⁾	Vertical pipes ⁽²⁾	Horizontal pipes ⁽³⁾	Vertical pipes ⁽³⁾	
32	0.8	1.0	0.4	0.5	6
40	0.8	1.0	0.4	0.5	6
50	0.8	1.0	0.4	0.5	6
56	0.8	1.0	0.4	0.5	6
63	0.8	1.0	0.4	0.5	6
75	0.8	1.1	0.4	0.6	6
90	0.9	1.4	0.5	0.7	6
110	1.1	1.7	0.6	0.9	6
125	1.3	1.9	0.7	1.0	6
160	1.6	2.4	0.8	1.2	6
200	2.0	3.0	1.0	1.5	6
250	2.0	3.0	1.0	1.5	6
315	2.0	3.0	1.0	1.5	6

(1) Horizontal run - spacings are 10 x OD, minimum 0.8m and maximum 2.0m

(2) Vertical Run – spacings are 15 x OD, minimum 1.0m and maximum 3.0m

(3) Before Expansion Socket – approximately half general spacing to guide pipe into socket

➤ Tooling and Equipment

HDPE Pipe Cutter



STOCK NO	SIZE
51590	-

HDPE Pipe Bevel Tool



STOCK NO	SIZE
51593	32mm - 160mm

HDPE Pipe Weld Scraper Tool



STOCK NO	SIZE
51592	-

Marker Crayons



STOCK NO	PACK QTY
08645	12



Testing Procedures

This page provides information on standard testing methods for waste and rainwater drainage. Ensuring that the pipework is properly secured is extremely important, and inspections and tests should be made during the installation of the discharge system as the work progresses. All work should be tested and free from defects before it is finally enclosed. Any specific project test requirements should be followed.

Testing with air:

An air test is normally carried out to confirm that all pipes and fittings are airtight. This should normally be completed in one operation, but for larger systems it is recommended to ensure access points are installed in appropriate positions so testing in sections can also be completed. Seal all open vents and connection to sewer with suitable test bungs, then use hand pump and manometer to pressurise and test. Ensure all bungs are removed before system operation!

Testing with smoke:

It is not recommended to carry out a smoke test on plastic pipework systems due to detrimental effect or embrittlement on plastics & rubber gaskets.

Leak detection:

A soapy water solution test can be applied to the pipes and joints. Leaks can then be detected by the formation of bubbles.

Testing with water:

It is not necessary to apply a water test to the whole of the drainage system. The part of the system at risk is that below the lowest sanitary appliance and this can be tested using a test plug in the lower end of the pipe and filling the pipe with water up to the flood level of the lowest sanitary appliance.

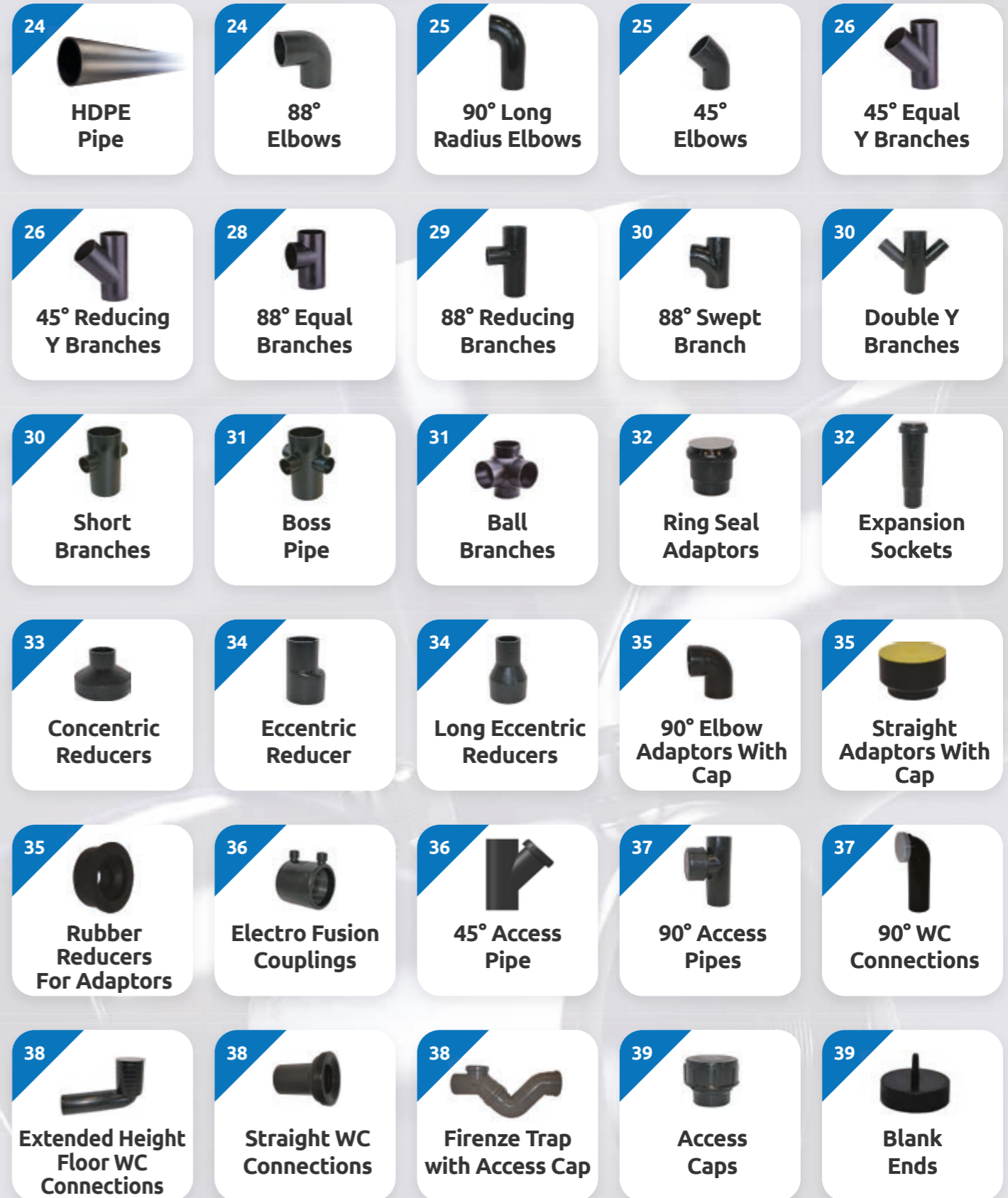

Product Range

▶ HDPE Pipe

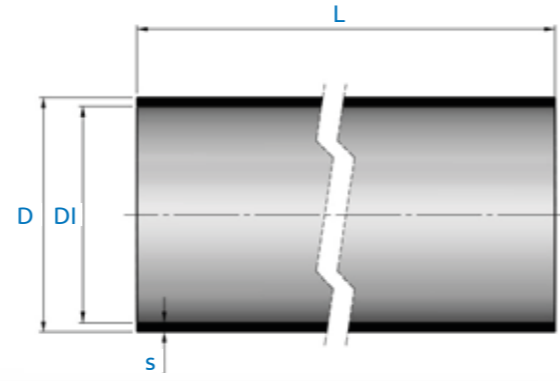

STOCK NO	D (mm)	L (m)	DI (mm)	S (mm)
51200	32	3	26	3
51201	40	3	34	3
51202	50	3	44	3
51203	56	3	50	3
51204	63	3	57	3
51205	75	3	69	3
51206	90	3	83	3.5
51207	110	3	101.4	4.3
51208	125	3	115.2	4.9
51209	160	3	147.6	6.2
51220	200	5	184.6	7.7
51221	250	5	230.8	9.6
51222	315	5	290.8	12.1

▶ 90° Long Radius Elbows

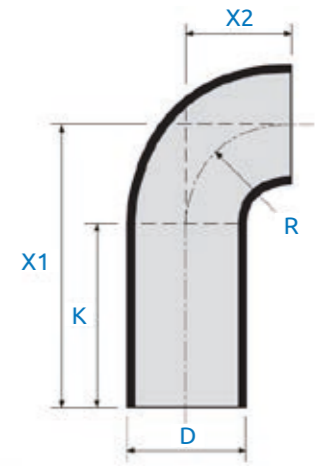

STOCK NO	D (mm)	X1 (mm)	X2 (mm)	R (mm)	K (mm)
51236	40	150	30	30	100
51237	50	180	40	40	125
51238	56	210	40	40	150
51239	63	210	50	50	140
51240	75	210	70	70	125
51241	90	240	90	90	135
51242	110	270	100	100	155
51243	125	200	110	110	75
51244	160	140	140	140	-
51245	200	200	200	200	-
51246*	250	335	335	335	-
51247*	315	370	370	370	-

* Prefabricated

▶ 88° Elbows

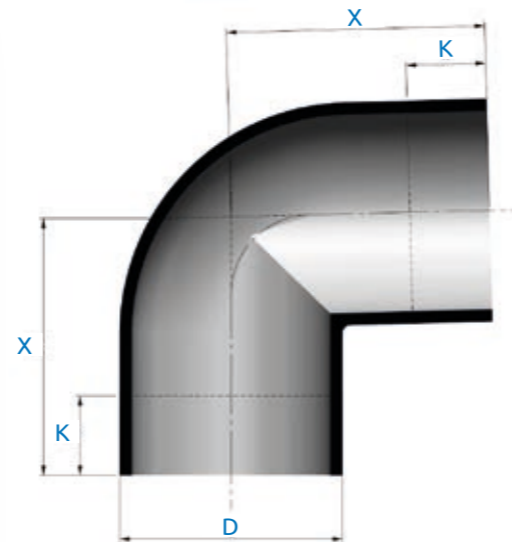

STOCK NO	D (mm)	X (mm)	K (mm)
51226	32	43	20
51227	40	50	20
51228	50	60	20
51229	56	65	20
51230	63	70	20
51231	75	75	20
51232	90	80	20
51233	110	95	25
51234	125	100	25
51235	160	-	-

▶ 45° Elbows

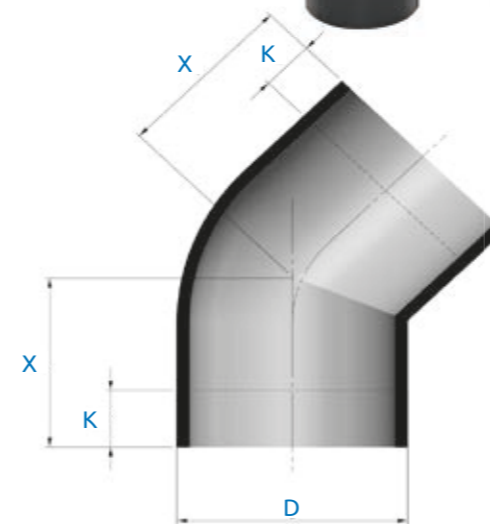

STOCK NO	D (mm)	X (mm)	K (mm)
51248	32	33	10
51249	40	40	15
51250	50	43	15
51251	56	45	15
51252	63	50	15
51253	75	50	15
51254	90	55	18
51255	110	60	20
51256	125	65	20
51257	160	74	22
51258	200	130	-
51259	250	220	-
51260	315	240	-

45° Equal Y Branches

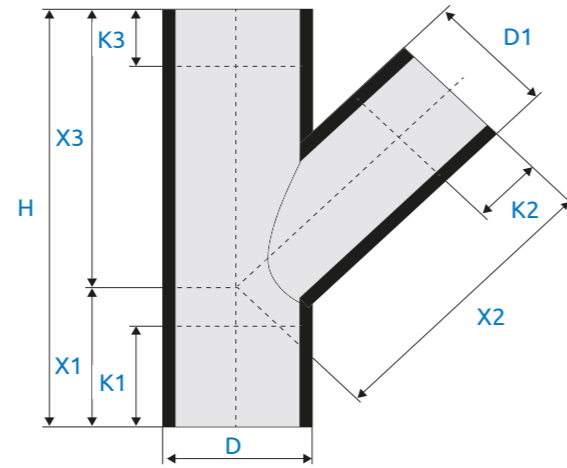

STOCK NO	D (mm)	D1 (mm)	H (mm)	X1	X2/X3 (mm)	K1 (mm)	K2 (mm)	K3 (mm)
51261	32	32	105	35	70	20	20	20
51262	40	40	135	45	90	20	10	10
51263	50	50	165	55	110	30	20	20
51264	56	56	180	60	120	35	25	30
51265	63	63	195	65	130	35	25	25
51266	75	75	210	70	140	40	20	20
51267	90	90	240	80	160	45	25	25
51268	110	110	270	90	180	50	20	20
51269	125	125	300	100	200	55	15	15
51270	160	160	375	125	250	75	20	20
51271	200	200	540	180	360	-	-	-
51272	250	250	660	220	440	-	-	-
51273	315	315	840	280	560	-	-	-

45° Reducing Y Branches

STOCK NO	D (mm)	D1 (mm)	H (mm)	X1	X2/X3 (mm)	K1 (mm)	K2 (mm)	K3 (mm)
51274	40	32	135	45	90	25	15	15
51275	50	40	165	55	110	35	25	25
51276	56	50	180	60	120	30	25	25
51278	63	50	195	65	130	45	30	35
51279	63	56	195	65	130	40	30	30

45° Reducing Y Branches (continued)

STOCK NO	D (mm)	D1 (mm)	H (mm)	X1	X2/X3 (mm)	K1 (mm)	K2 (mm)	K3 (mm)
51281	75	50	210	70	140	55	30	35
51282	75	56	210	70	140	50	30	35
51284	75	63	210	70	140	45	25	30
51285	90	40	240	80	160	75	45	60
51286	90	50	240	80	160	70	40	55
51287	90	63	240	80	160	65	35	45
51288	90	75	240	80	160	55	30	35
51289	110	40	270	90	180	85	50	70
51290	110	50	270	90	180	85	45	60
51291	110	56	270	90	180	85	45	55
51292	110	63	270	90	180	80	40	50
51293	110	75	270	90	180	75	35	40
51294	110	90	270	90	180	65	30	30
51300	125	90	300	100	200	80	40	40
51301	125	110	300	100	200	65	25	25
51304	160	56	375	125	250	155	90	110
51306	160	75	375	125	250	120	70	80
51308	160	110	375	125	250	110	55	55
51309	160	125	375	125	250	95	40	45
51311	200	50	490	180	360	225	175	155
51312	200	56	490	180	360	220	170	150
51314	200	75	540	180	360	-	-	-
51316	200	110	540	180	360	-	-	-
51318	200	160	540	180	360	-	-	-
51323	250	75	660	220	400	-	-	-
51324	250	90	660	220	400	-	-	-
51325	250	110	660	220	440	-	-	-
51326	250	160	660	220	440	-	-	-
51327	250	200	660	220	440	-	-	-
51329	315	110	840	280	560	-	-	-
51331	315	160	840	280	560	-	-	-
51332	315	200	840	280	560	-	-	-
51333	315	250	840	280	560	-	-	-

88° Equal Branches

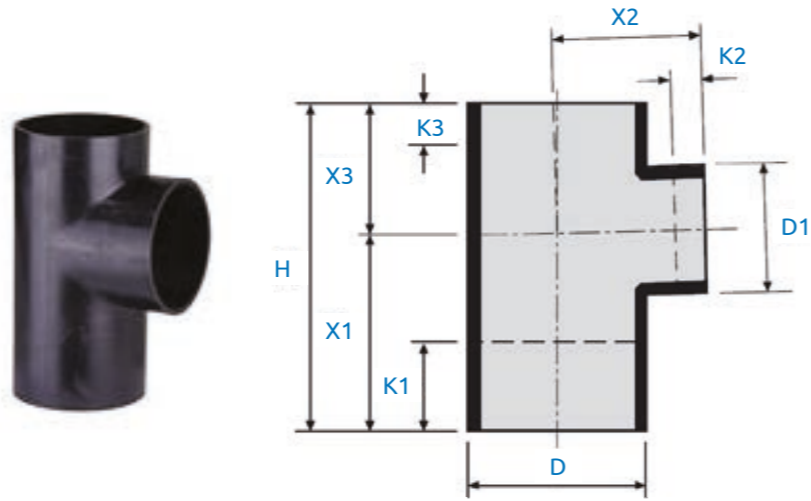

STOCK NO	D (mm)	D1 (mm)	H (mm)	X1 (mm)	X2 (mm)	X3 (mm)	K1 (mm)	K2 (mm)	K3 (mm)
51340	32	32	96	62	34	34	25	10	10
51341	40	40	125	75	50	50	40	10	10
51342	50	50	150	90	60	60	50	15	15
51343	56	56	150	90	60	60	45	10	15
51344	63	63	175	105	60	60	55	20	20
51345	75	75	175	105	70	70	50	15	15
51346	90	90	200	120	80	80	60	15	15
51347	110	110	225	135	90	90	65	15	15
51348	125	125	250	150	100	100	70	15	15
51349	160	160	350	210	140	140	115	40	40
51350	200	200	360	180	180	180	-	-	-
51351	250	250	440	220	220	220	-	-	-
51352	315	315	560	280	280	280	-	-	-

88° Reducing Branches



STOCK NO	D (mm)	D1 (mm)	H (mm)	X1 (mm)	X2 (mm)	X3 (mm)	K1 (mm)	K2 (mm)	K3 (mm)
51654	40	32	125	75	50	50	40	20	15
51355	50	40	150	90	60	60	55	15	20
51356	56	50	175	90	60	60	50	15	15
51360	75	50	175	105	70	70	65	15	25
51361	75	56	200	105	70	70	60	15	25
51363	90	40	200	120	80	80	85	15	40
51364	90	50	200	120	80	80	80	15	35
51365	90	56	225	120	80	80	75	15	35
51368	110	40	225	135	90	90	90	15	50
51369	110	50	225	135	90	90	95	15	45
51370	110	56	225	135	90	90	90	15	40
51372	110	75	225	135	90	90	80	15	35
51373	110	90	350	135	90	90	75	15	25
51379	160	75	350	210	140	140	155	40	70
51375	160	110	350	210	140	140	140	40	65
51376	160	125	360	210	140	140	130	40	55
51380	200	110	360	180	180	180	-	-	-
51381	200	160	360	180	180	180	-	-	-
51382	250	110	440	220	220	220	-	-	-
51383	250	160	440	220	220	220	-	-	-
51384	250	200	440	220	220	220	-	-	-
51385	315	110	560	280	280	280	-	-	-

88° Swept Branch



STOCK NO	D (mm)	D1 (mm)	H (mm)	X1 (mm)	X2 (mm)	K1 (mm)	K2 (mm)	K3 (mm)
51353	110	110	219	127.7	127.7	32	32	32

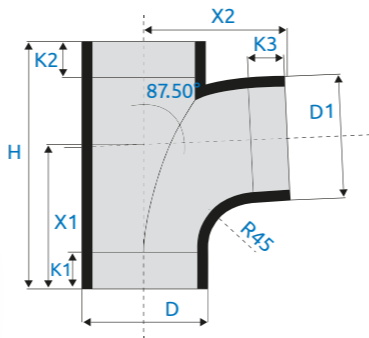

45° Double Y Branches



STOCK NO	D (mm)	D1 (mm)	H (mm)	X1 (mm)	X2/X3 (mm)	K1 (mm)	K2 (mm)	K3 (mm)
51390	110	50	270	90	180	90	45	50
51391	110	110	270	90	180	50	15	10

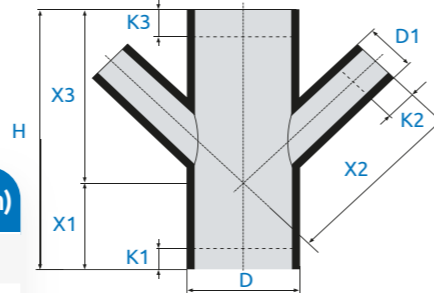

180° Short Double Branch – 2 Way



STOCK NO	D (mm)	D1 (mm)	H (mm)	X1 (mm)	X2 (mm)	K1 (mm)	K2 (mm)	K3 (mm)
51392	110	50	225	135	90	95	25	50

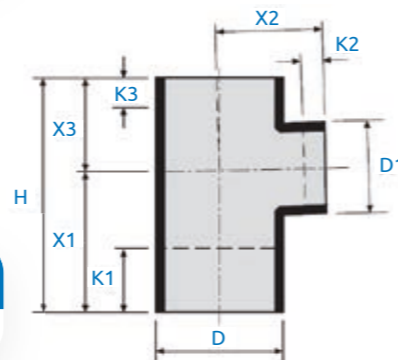

90° Short Corner Branch – 2 Way



STOCK NO	D (mm)	D1 (mm)	H (mm)	X1 (mm)	X2 (mm)	K1 (mm)	K2 (mm)	K3 (mm)
51393	110	50	225	135	90	95	25	50

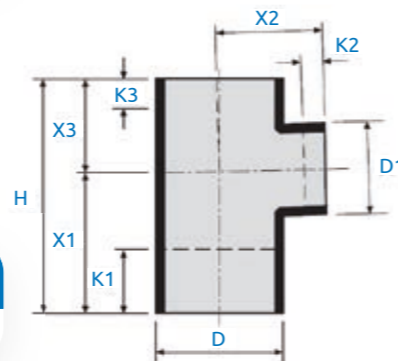

Short Boss Pipe – 4 Way



STOCK NO	D (mm)	D1 (mm)	H (mm)	X1 (mm)	X2 (mm)	K1 (mm)	K2 (mm)	K3 (mm)
51556	110	56	225	135	90	99	90	90

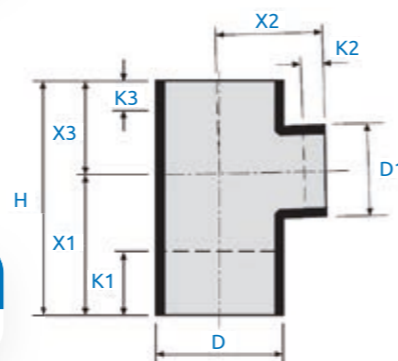

3 outlets closed

90° Corner Ball Branch – 2 Way



STOCK NO	D (mm)	D1 (mm)	H (mm)	X1 (mm)	X2 (mm)	X3 (mm)	K1 (mm)	K2 (mm)	K3 (mm)
51396	110	110	200	100	120	100	15	35	15

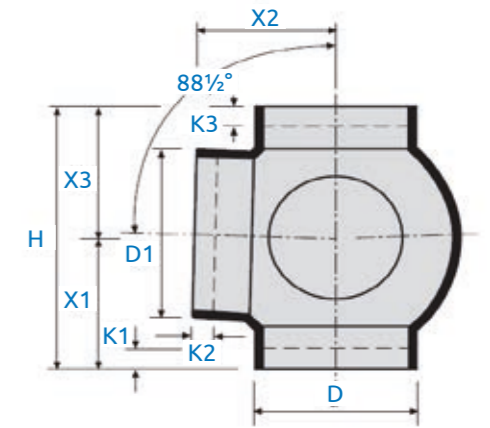

180° Double Ball Branch – 2 Way



STOCK NO	D (mm)	D1 (mm)	H (mm)	X1 (mm)	X2 (mm)	X3 (mm)	K1 (mm)	K2 (mm)	K3 (mm)
51397	110	110	200	100	120	100	15	35	15
51398	110	50	200	100	120	100	15	20	15

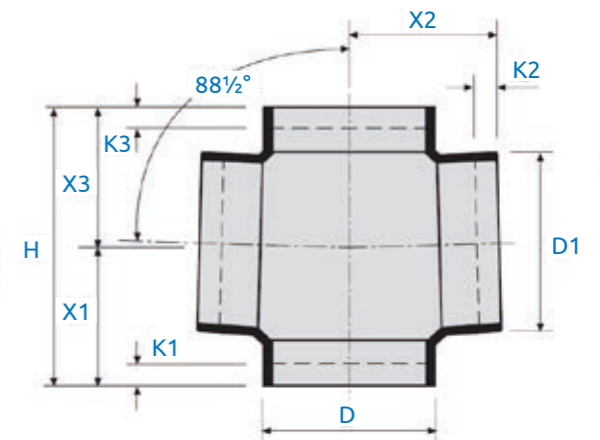

Ball Branch – 4 Way

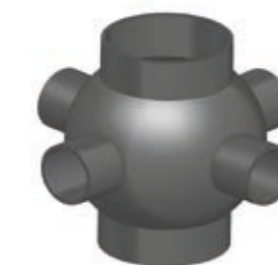

STOCK NO	D (mm)	D1 (mm)	H (mm)	X1 (mm)	X2 (mm)	X3 (mm)	K1 (mm)	K2 (mm)	K3 (mm)
51399	110	110	200	100	120	100	15	35	15
51400	110	50	200	100	120	100	15	20	15

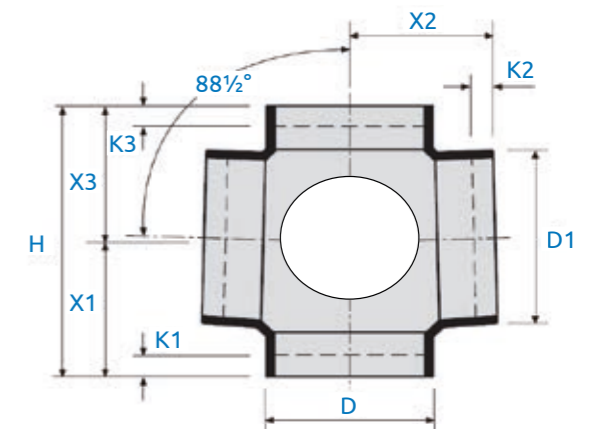

Ring Seal Adaptors

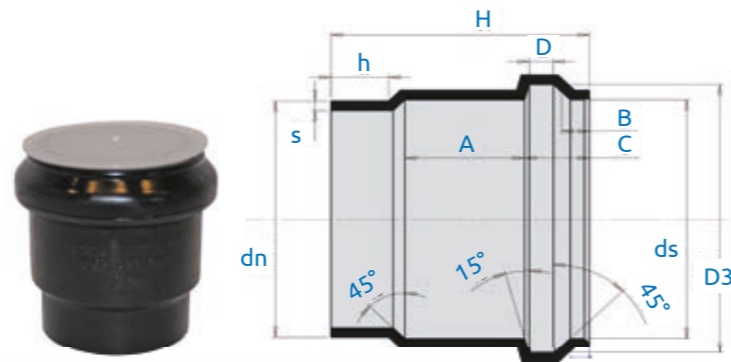

STOCK NO	dn (mm)	ds (mm)	D3 (mm)	A (mm)	B(mm)	C (mm)	D (mm)	H (mm)	h (mm)	s (mm)
51403	32	32.4	39.5	30.5	8.0	17.7	7	63	10	3
51404	40	40.5	50.5	30.5	8.0	18.7	7	70	16	3
51405	50	50.6	60.5	30.5	8.0	18.7	7	70	16	3
51406	56	56.6	66.5	32	8.0	18.7	7	71	16	3
51407	63	63.7	73.5	32	8.0	18.7	7	71	16	3
51409	75	75.8	85.5	35	8.1	18.7	7	75	17	3
51410	90	91	100	38	8.0	18.8	7	78	16	3.5
51411	110	111.1	121	42	8.1	18.8	7	84	17	4.2
51412	125	126.3	137	44	8.2	19.2	7	87	16	4.8
51413	160	161.6	178	65	17.1	30.2	7	125	20	6.2

Expansion Sockets

Suitable for fusion coupler

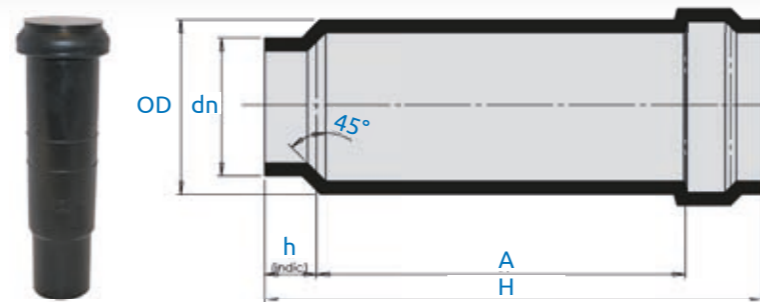

STOCK NO	DN (mm)	OD (min)	H (Nominal length mm)	A (Nominal length mm)	h (spigot length mm)
51417	32	47	116	80	12
51418	40	47	225	142	58
51419	50	57	226	145	55
51420	56	64	235	153	55
51421	63	70	235	150	55
51422	75	83	230	145	55
51423	90	100	230	145	55
51424	110	1216	235	145	55
51425	125	142	235	145	55
51426	160	176	250	135	63
51427	200	217	350	215	55
51428	250	272	410	190	100
51429	315	342	480	200	145

Concentric Reducers

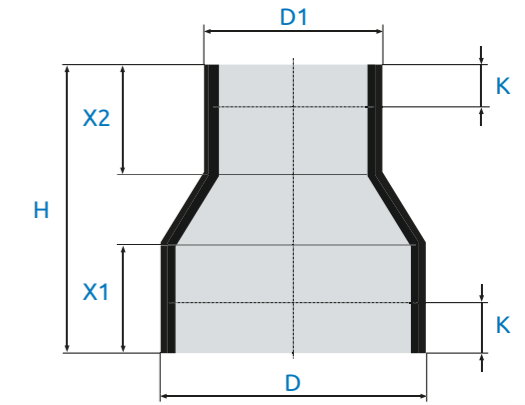

STOCK NO	D (mm)	D1 (mm)	H (mm)	X1 (mm)	X2 (mm)	K (mm)
51430	40	32	80	30	30	10
51431	50	40	80	30	30	10
51432	56	50	80	30	30	10
51438	75	40	80	30	30	10
51439	75	50	80	30	30	10
51442	90	40	80	30	30	10
51443	90	50	80	30	30	10
51444	90	56	80	30	30	10
51447	110	40	80	30	30	10
51448	110	50	80	30	30	10
51449	110	56	80	30	30	10
51450	110	63	80	30	30	10
51451	110	75	80	30	30	10
51452	110	90	80	30	30	10
51458	125	110	80	30	30	10
51459	160	110	95	40	30	15
51453	200	110	245	125	30	-
51460	200	160	280	125	30	-

▶ Eccentric Reducer

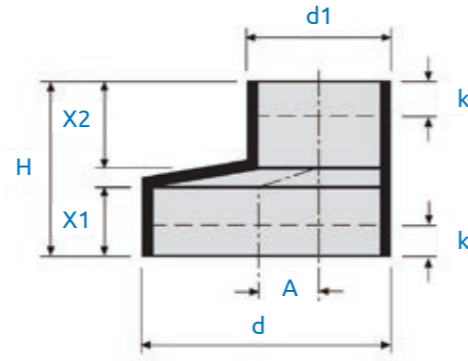

STOCK NO	d (mm)	d1 (mm)	H (mm)	X1 (mm)	X2(mm)	k (mm)	A (mm)
51461	50	40	80	35	37	20	5
51462	56	50	80	35	37	20	3
51463	63	40	80	35	37	20	11.5
51464	63	50	80	35	37	20	6
51465	63	56	80	35	37	20	3
51467	75	50	80	35	37	20	12
51468	75	56	80	35	37	20	10
51472	90	56	80	35	37	20	16
51473	90	63	80	35	37	20	13
51474	90	75	80	35	37	20	7
51475	110	40	80	35	37	20	33.7
51476	110	50	80	35	37	20	29
51477	110	56	80	35	37	20	26
51479	110	75	80	35	37	20	16
51480	110	90	80	35	37	20	9
51485	125	90	80	35	37	20	16
51486	125	110	80	35	37	20	7
51487	160	110	90	40	42	25	23
51488	160	125	90	40	42	25	16
51489	200	125	415	170	115	30	37

▶ Long Eccentric Reducers



STOCK NO	d (mm)	d1 (mm)	H (mm)	X1 (mm)	X2(mm)	k (mm)	A (mm)
51567	200	110	445	170	130	30	45
51568	200	125	415	170	115	30	37
51569	200	160	330	170	90	30	20
51570	250	200	405	158	157	30	25
51571	315	200	580	161	157	30	57
51572	315	250	435	161	157	30	32

▶ 90° Elbow Adaptors With Cap

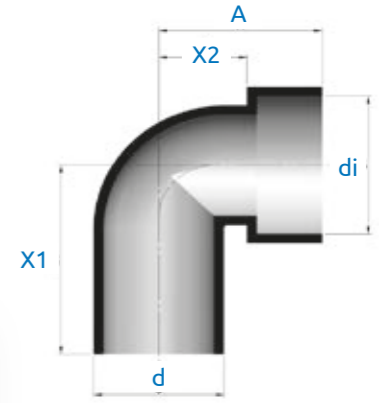

STOCK NO	d (mm)	di (mm)	A (mm)	X1 (mm)	X2 (mm)
51490	40	46	50	63	27
51491	50	46	50	63	27

▶ Straight Adaptors With Cap

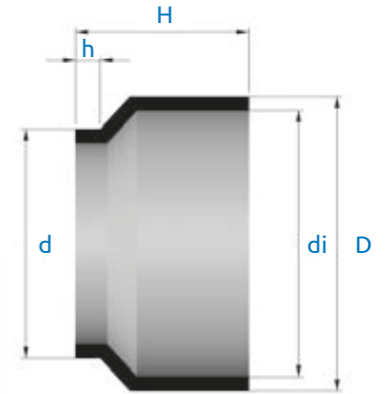

STOCK NO	d (mm)	di (mm)	D (mm)	H (mm)	h (mm)
51496	40	46	52	31	4
51497	50	46	52	31	5
51498	50	58	64	35	5

▶ Rubber Reducing Adaptors

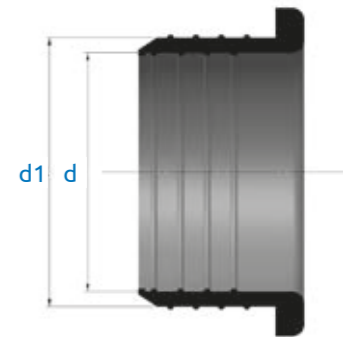

STOCK NO	d (mm)	d1 (mm)
51501	26-32	46
51502	36-40	46
51811	36-40	50
42198	40-44	50
51505	47-50	58

Electro Fusion Couplings

STOCK NO	d (mm)	D (mm)	H (mm)
51506	32	43	61
51518	40	51	61
51519	50	61	61
51520	56	68	61
51521	63	75	61
51522	75	89	61
51523	90	106	61
51524	110	126	61
51525	125	142	61
51526	160	177	61
51527	200	225	160
51528	250	281	160
51529	315	350	160

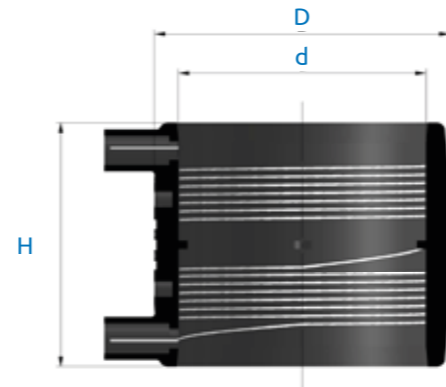

45° Access Pipe

STOCK NO	d (mm)	d1 (mm)	H (mm)	X1 (mm)	X3 (mm)	a (mm)	k (mm)	A (mm)	STP	C
51558	110	128	270	90	180	65	50	210	089	C0400240

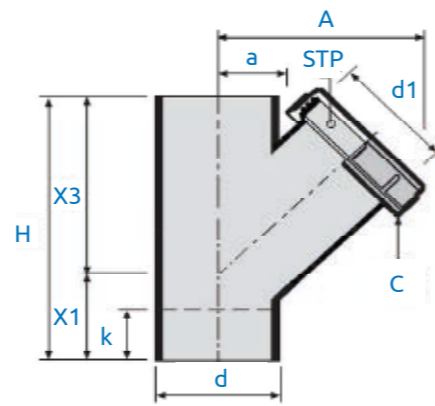

90° Access Pipes

STOCK NO	d (mm)	d1 (mm)	H (mm)	X1 (mm)	X3 (mm)	A (mm)
51503	32	32	96	62	34	77
51507	50	50	150	90	60	75
51509	63	86	174	108	66	85
51510	75	108	174	108	66	85
51511	90	123	200	120	80	95
51512	110	145	225	135	90	105
51513	125	145	250	150	100	115
51514	160	145	350	210	140	130
51515	200	145	350	180	170	160
51516	250	145	440	220	220	190
51517	315	145	560	280	280	225

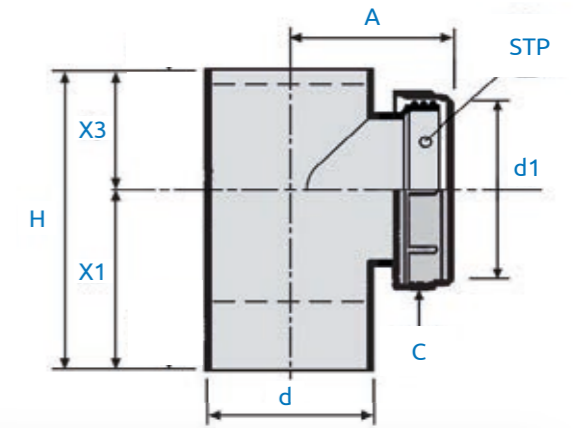

90° WC Connections

STOCK NO	d (mm)	d1 (mm)	h (mm)	X1 (mm)	X2 (mm)	STP
51530	110	90	80	300	43	STP091-DN90
51531	110	110	80	300	43	STP091-DN110

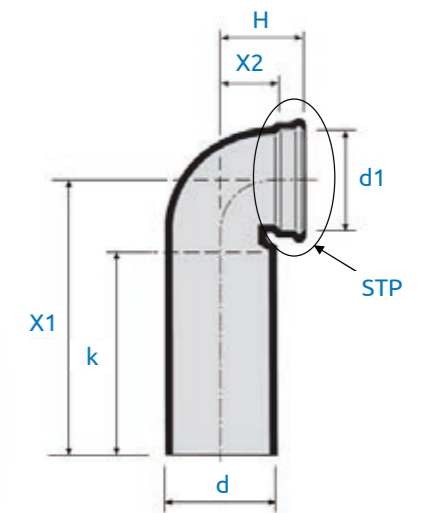

Extended Height Floor WC Connections

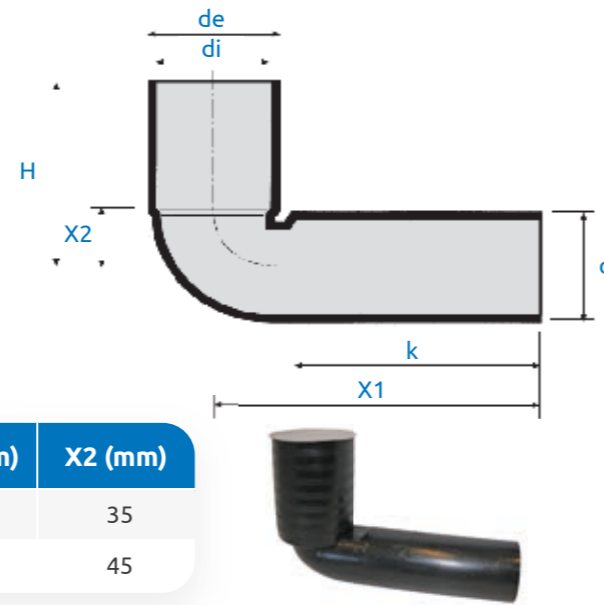

STOCK NO	d (mm)	de (mm)	di (mm)	H (mm)	X1 (mm)	X2 (mm)
51532	90	120	114	180	300	35
51533	110	120	114	190	300	45

Straight WC Connections

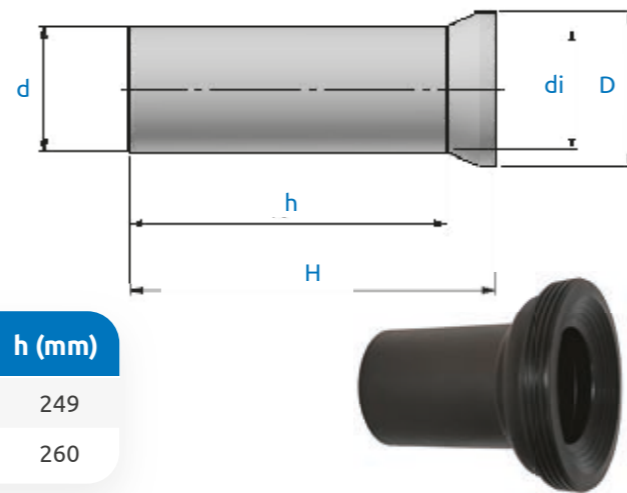

STOCK NO	d (mm)	D (mm)	di (mm)	H (mm)	h (mm)
51536	90	135	85 ± 5	300	249
51538	110	135	105 ± 5	300	260

Firenze Trap with Access Cap

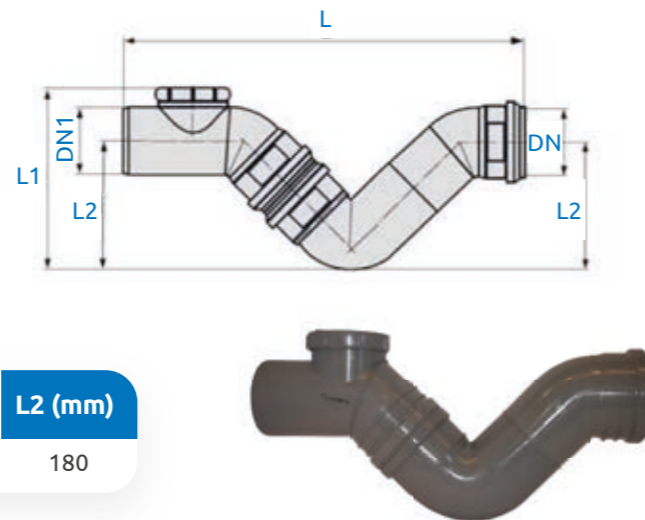

STOCK NO	DN (mm)	DN1 (mm)	L (mm)	L1 (mm)	L2 (mm)
51539	110	110	535	260	180

Access Caps

STOCK NO	d (mm)	D (mm)	H (mm)	h (mm)
51559	32	56	45	26
51560	40	64	60	33
51561	50	72	60	33
51562	56	84	60	35
51563	63	86	62	42
51564	75	108	85	42
51565	90	124	85	50
51566	110	145	90	60

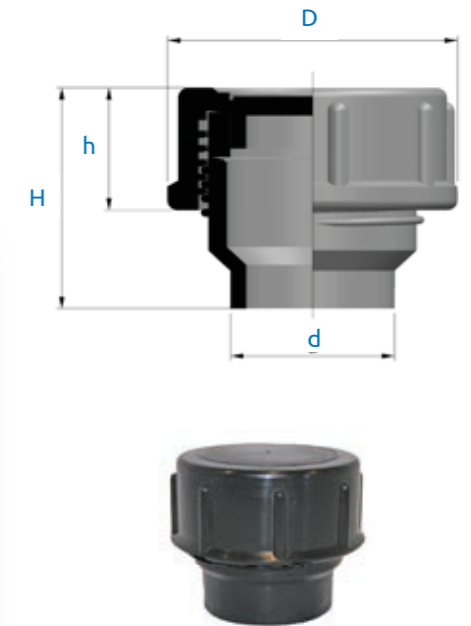

Blank Ends

STOCK NO	d (mm)	h (mm)
51573	32	15.0
51574	40	15.0
51575	50	15.0
51576	56	15.0
51577	63	15.0
51578	75	15.0
51579	90	10.5
51580	110	16.0
51581	125	16.5
51582	160	25.5
51583	200	25.5
51584	250	92
51585	315	115

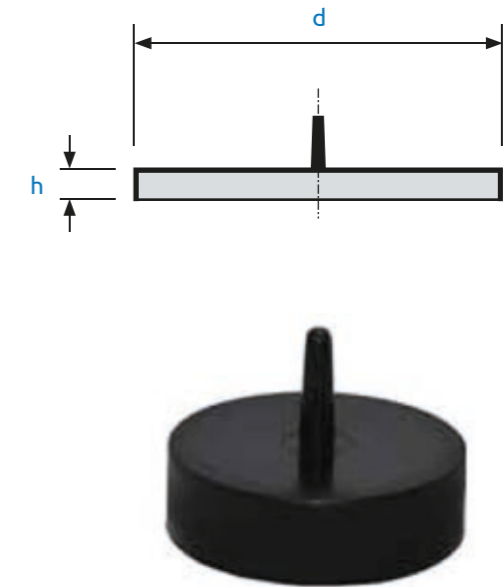

➤ Pipe Clamps

Pipe Clamps



SIZE	ACOUSTIC	HEAVY DUTY ACOUSTIC	LOW FRICTION	UNLINED	HEAVY DUTY UNLINED
	STOCK NO	STOCK NO	STOCK NO	STOCK NO	STOCK NO
32mm	04099		04143	04003	04940
40mm	04100		04144	04004	04941
50mm	04113		04159	04005	04942
56mm	04102		04145	04006	04996
63mm	04103	42037	04152	04007	04943
75mm	04105	42038	04147	04000	04945
90mm	04106	42044	04148	04010	04947
110mm	04108	42039	04149	04014	04949
125mm	04109	42209	-	04015	04952
160mm	04112	42041	04151	04021	04955
200mm	04134	42210	-	04025	04958
250mm	04135	42211	-	-	04961
315mm	04136	42048	-	-	04964

➤ Threaded Coupling (Compression Nut & Seal)

STOCK NO	Size
51534	110mm

➤ Griffon PE/PP/PVDF Cleaning Fluid

STOCK NO	Size
51810	1000ml

➤ Fire Stop Products

Manufactured from a high performance material bonded to the inside of a steel sleeve. Suitable for when plastic soil and waste pipes pass through fire compartment walls and floors. On exposure to heat from a fire they rapidly expand inwards to squeeze the collapsing plastic pipe until the aperture is completely sealed. Tested in accordance with the performance requirements of BS476: Part 20: 1987 & EN1366-3, NHBC type approval.

Intumescent Pipe Collars

- Tested to BS476: Part 20 and EN1366-3
- For use on UPVC, ABS, MDPE, HDPE and PP pipes
- Up to 4 hours fire resistance
- Surface mounted, cast or semi-cast applications



STOCK NO	SIZE	RATING
040538	32mm	4 Hour
040582	40mm	4 Hour
040539	50mm	4 Hour
040540	56mm	4 Hour
040540	63mm	4 Hour
040541	75mm	4 Hour
040543	90mm	4 Hour
040544	110mm	4 Hour
040547	160mm	4 Hour
040535	200mm	4 Hour
040537	250mm	4 Hour
ZZ030952	315mm	3 Hour

Intumescent Acoustic Sealant

- The Intumescent Acoustic Sealant is a one part acrylic emulsion sealant giving good fire resistance to BS476 Part 20
- It is a water based paste which cures on application due to evaporation of moisture
- It can be overpainted and has good movement accommodation
- Up to 4 hours fire resistance



STOCK NO	SIZE
08231	310 ml

Fire Rated Acoustic Foam - B1 Rating

- Fire rated Acoustic Foam acts as a primary fire seal in accordance with BS476 Part 20 up to 4 hours and meets Class B1 of DIN 4102 Part 1



STOCK NO	SIZE
08063	750 ml

Intumescent Putty

- An easy to use, non setting intumescent compound, which is ideal for sealing around pipes and cables in walls and floors



STOCK NO	SIZE
40573	1kg

Fire Batt - 4 Hour Fire Rating

- Tested to BS476: Part 20
- Up to 4 hours fire resistance
- Economical
- Halogen free
- Reduced smoke properties
- Chemical / weather resistant



STOCK NO	SIZE
040591	1200 x 600 x 60mm

Fire Rated Silicone

- This fire rated silicone offers superior qualities combined with excellent movement accommodation, temperature stability, UV resistance and ageing characteristics
- It offers excellent resistance to fire in accordance with BS476 Parts 20 and 22 and conforms to ISO 11600 - F&G - 2SLM and BS5889 Type A



STOCK NO	SIZE
08174	310 ml

Installation Instructions - HDPE

Butt Weld

This method of jointing allows the greatest space saving. The jointing process is performed using a welding machine with jaws, miller and heating plate.

For diameters up to 63 mm, the jointing process can be carried out with a heating plate only. For diameters over 63mm, alignment clamps must be used on the welding machine and the lever mechanism used to maintain contact with the heat plate.

1. Ensure the environmental conditions are suitable before commencing the jointing process. When the outside temperature is below 5°C and/or during rainy and windy conditions, special precautionary measures should be taken.
2. Check to ensure the welding machine is in good functional order paying particular attention to: temperature, alignment of the moving parts, electrical connections, cutting machining plate (sharpness), heat plate cleanliness.
3. Check that the heat plate is at 210°C +/- 5°C.
4. Cut pipe to required length noting that during welding a few mm of pipe will be lost during the process. Ensure the pipe ends are square and deburr to remove rough edges.
5. Clamp both ends of the pipe into the welding machine, ensuring that they are correctly aligned.
6. Using the planer, trim both ends of the pipe. Ensure that you do not stop the planer when in contact with the pipe as this can create a rough/uneven surface.
7. Insert the heat plate and press both pipe ends for a few seconds to ensure full contact.
8. Steadily reduce the force until nearly zero, ensuring contact with the heat plate.
9. Maintain the heat soaking process until a bead is formed of approximate 1mm for diameters 32mm up to 200mm and 1.5mm for diameters 250mm and 315mm.
10. After the heating cycle is up, open the welding machine, remove the heat plate and close the joint quickly. This stage of the process should be kept to the minimum amount of time as possible to ensure too much heat is not lost.
11. Apply welding force and maintain for the required cooling time.
12. Inspect weld bead to ensure it is even, an uneven bead can indicate incorrect alignment. Large weld beads can be caused by too high temperature during the welding process or too much force applied during welding. In both cases the integrity of the weld will be questionable and therefore it should be rejected.
13. At the end of the above process remove the joint from the welding machine after the cooling period has elapsed. The joint requires 5 minutes after cooling before any pressure can be applied.

Installation Instructions - HDPE

Electrofusion

The most practical method of jointing on site, this process requires a welding machine that supplies an electrical current to the pipe sleeve to bring it to the point of fusion to connect the pipe and/or fitting. The welding action affects only the exterior surfaces of the pipe and/or fittings maintaining the internal integrity of the pipe.

1. Clean and cut the pipe precisely square with pipe cutters and deburr the edges.
2. Check the fusion ends with a measuring tape before and after the peeling operation. Adhere to standards and specifications (EN12666-1).

Minimum wall reduction by peeling 0.2mm

DIAMETER Ø	32	40	50	56	63	75	90	110	125	160	200	250	315
Min. pipe Ø (mm)	31.6	39.6	49.6	55.6	62.6	74.6	89.6	109.6	124.6	159.6	199.6	249.6	314.6
Cooling Time (min)	10	10	10	10	10	15	15	15	15	15	20	20	20

3. Calculate the peeling length for the coupler by measuring the coupler and using the formula (coupler length / 2) + 10mm. In the instance of using a sliding coupler or repair coupler the peeling length is equal to the length of the coupler. Remove centre stop with a knife.
4. Measure and mark the area to be peeled with a permanent marker.
5. Peel the pipe. Do not use abrasive paper. Minimum peeling thickness is 0.2mm.
6. Using HDPE cleaner, clean the peeled area of the pipe with a lint free cloth.
7. Mark the insertion depth with a permanent marker using the formula (coupler length/2)
8. Using HDPE cleaner, clean the electro fusion coupler.
9. To ensure a low stress installation secure the pipe and coupler to avoid movement.
10. Strictly follow the instructions on the welding machine. DO NOT touch the electro fusion coupler during fusion.

Check the display on the fusion unit throughout the process. When it indicates the fusion process is successful remove the fusion cables. Check the couplers fusion indicators; both should be visible. If not the coupler must be removed by cutting it out and the process should be repeated with a new coupler.

Ring Seal

A jointing method that offers a removable joint, this is useful when pipework needs to be connected together with the practicality of removal if necessary. Ring seal does not provide stress resistance and should therefore be used with a suitable anchoring system.

1. Before connecting pipe and fittings inspect the integrity of the O-ring.
2. Lubricate the seal using silicone grease.
3. Chamfer the pipe/fitting to be connected to approximately 15 degrees.
4. Insert the pipe/fitting. For expansion sleeves follow the directions printed on them.

➤ Delivery and Site Storage

Transport

In the event of pipes being removed from their factory packaging please ensure that they are stacked straight, level and interlocking to prevent deformation (Fig 1).

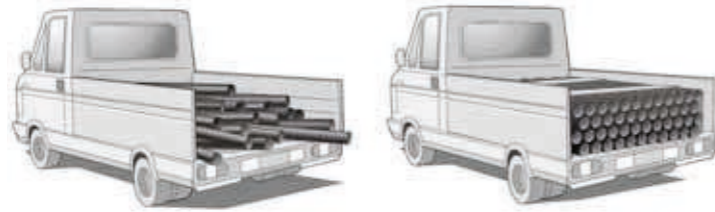

Fig. 1

Avoid dragging pipes on the ground or against the sides and tailgate of the vehicle (Fig 2).



Fig. 2

Storage

Pipe stacking

In the event of pipes being removed from their factory packaging please ensure that they are stacked straight, level and interlocking to prevent deformation.

- Pipes should be placed on flat and smooth surfaces.
- In order to prevent deformations over time, the maximum stacking height must be no more than 2m, whatever their diameter may be.
- Outdoor storage must not exceed 2 years.

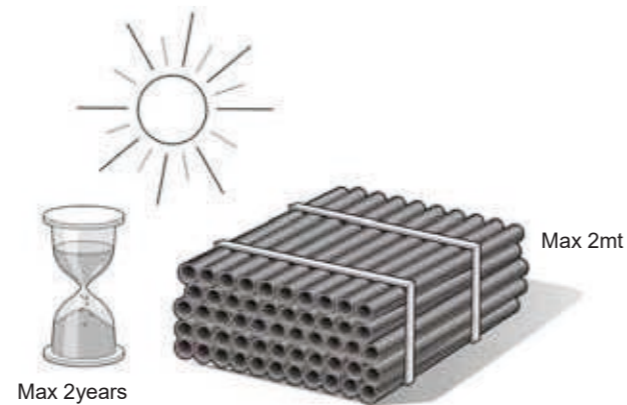

Fig. 3

Fittings storage

- The same criteria used for pipes also applies to fittings; they should be stored with care and protected from sunlight.



➤ Brymec Technical Support

We recognise the importance of having top quality support from the manufacturer throughout every phase of the construction process, so we are here to provide assurance, technical support and assistance to safeguard your project.

Our Technical Team can assist you from Pre-construction right through to Post Contract and make sure that our attention to detail will be an asset for you.

Key Areas of Support

Specification

To ensure that our products suit the application in the best possible way we can offer advice or assistance at this stage.

Project Support

This includes our excellent installation training, site attendance visits, verification and testing when required. Our Technical Laboratory provides quick results from all testing and analysis.

Post Contract

We can assist with full details for O & M Building Manuals, project information and records.

In-House Laboratory/Testing Facility

We have a purpose build laboratory to test our products to ensure they are of the utmost quality for your projects.

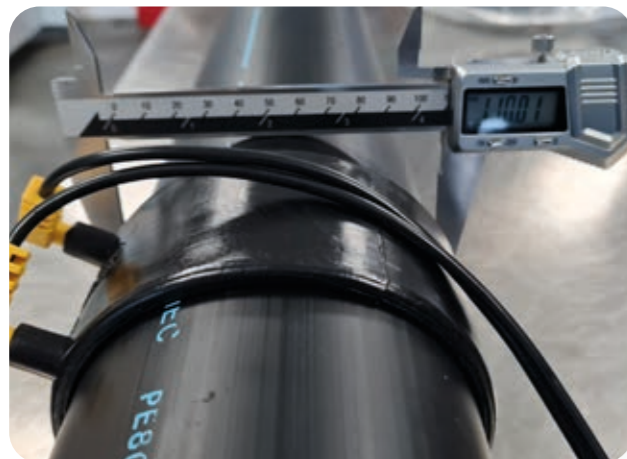

➤ Warranty On Brymec HDPE System

At Brymec we place a huge emphasis on the quality and design of our range of manufactured products. We carry out extensive research, evaluation and design and then integrate Quality Checks at all stages of our processes.

Our HDPE Drainage range has been carefully designed and selected to meet the highest quality standards and the requirements of EN 1519-1. Products undergo stringent testing in compliance with our ISO 9001:2015 Quality Management System.

Due to the proven quality and reliability of the products, when using the Brymec HDPE Drainage System, Brymec provide a product warranty up to a maximum of 10 years from the date of delivery.

This 10-year guarantee is against faults caused by defective manufacturing of Brymec HDPE.

To qualify for this warranty all items must be installed correctly, for the correct application, in conjunction with correct adjacent materials and in the correct environment, within stated limits of use and performance as stated in our product information, data and any installation, operation and maintenance instructions which can be requested from us and on our website. All systems must be installed and operated within the designed product standard of BS EN 1519-1 and be subject to a suitable regular inspection and maintenance schedule.

To view the full warranty terms and conditions visit brymec.com/warranty





➤ Mount Pleasant Phase 3 Case Study



The Project

Mount Pleasant is a 'Postmark' development in the small district of Farringdon, Central London. The new development was originally the site of the Royal Mail sorting office.

This exciting project involves the construction of a mixed-use development which will include:

- 336 residential units,
- Over 4,000 sqm office space
- Over 1,400 sqm community space
- Car and cycle parking and Public open space

The residential units are spread across 5 blocks, ranging from 3-11 storey buildings. The project has added complexity due to being constructed over a basement with complex structures of the existing underground postal tunnels.

The private & shared ownership residential units have been designed to achieve a BREEAM Very Good rating as well as a code for Sustainable Homes Level 4. With this, all products sourced for the construction is carefully reviewed to ensure that the completed homes meet the standards.

The Challenge

With every project, much thought and consideration is given to every single stage of the development, ensuring that the plans are safe and can accommodate all requirements. This was no exception for the Mount Pleasant project.



➤ Mount Pleasant Phase 3 Case Study (continued)



The project is on a strict deadline, with the housing development moving quickly to house residents into the new units by the end of 2023.

With installations moving along swiftly, the mechanical contractor [FG Mechanical] required the products on site without delay.

Product Selection

Brymec products including HDPE Drainage and Steel Tube & Fittings were amongst the items selected for use on the project.

The Brymec HDPE commercial waste & drainage system is a lightweight and highly efficient pipework system which is perfectly suited for soil & waste and rainwater drainage. Manufactured from high-density polyethylene it has numerous advantages over other materials.

The Result

Brymec carry vast stocks of products to enable us to support the largest projects in a unique way. The quality of the products, full availability and accuracy of delivery to site is spoken of as a great asset by our Customers.

With the collaboration between the mechanical contractor [FG Mechanical] and Brymec, regular orders were placed with the peace of mind that they

would be delivered next day at the requested time.

Being able to provide materials from stock as and when required and keeping up with the delivery demands has allowed the project to continue smoothly with no delay.

Matthew Bowden from FG Mechanical states

"Brymec is always on time with quick and efficient service, which we love. It's always quick deliveries and quick quotes and it makes a huge difference for us on site. Basically, am happy with the speed and efficient turnaround of every part of an order with Brymec Our account manager Danny is fantastic with communication and involved with the project all the way through and I know I can always give him a call and he will be able to help whether it be a technical, product or service question. He always helps. Very happy with everything the Brymec does to support us on projects."

➤ Terms of Business

1. BACKGROUND

1.1 These Terms apply to the Contract between Brymec and the Customer for the sale of Brymec Products. Any other terms, whether implied by custom or practice, or which the Customer may seek to include, are specifically excluded.

1.2 Capitalised words (such as 'Contract'), have a specific meaning which is set out in 10 below.

2. CONTRACT TO BUY PRODUCTS

2.1 The Products are described on Brymec's website and in its catalogue. Specifications for Products are subject to change, in which case, Brymec will endeavour to supply an equivalent or suitable alternative.

2.2 When the Customer wishes to place an order for Products, it will provide a purchase order to Brymec. If Brymec accepts such order, it will issue an Order Acceptance to the Customer, at which point the Contract shall come into existence.

2.3 The Customer is responsible for ensuring that the details in the Order Acceptance are complete and accurate.

3. DELIVERY

3.1 Each delivery of the Products will be accompanied by a delivery note that shows the date of the Order Acceptance, the relevant Brymec reference number, and the type and quantity of the Products.

3.2 Brymec shall deliver the Products to the Delivery Location at any time after Brymec notifies the Customer that the Products are ready.

3.3 Delivery is completed on the completion of unloading of the Products at the Delivery Location (and, if applicable, Signed For.)

3.4 Customer must notify any issues of non-delivery, discrepancy or damage to Brymec within 2 business days of Delivery (see further 4.2 below).

3.5 Any dates quoted for delivery are approximate only, and the time of delivery is not of the essence. Brymec shall use all reasonable commercial efforts to meet any specific delivery dates. However, Brymec will not be liable for any delay in delivery of the Products.

3.6 If Brymec fails or is unable to deliver the Products for any reason (except for an Unforeseen Event), its liability shall be limited to the costs and expenses incurred by the Customer in obtaining replacement Products of similar description and quality in the cheapest market available, less the price of the Products. Brymec shall have no liability for any failure to deliver the Products to the extent that such failure is caused

by an Unforeseen Event, or the Customer's failure to provide Brymec with adequate delivery instructions or any other instructions that are relevant to the supply of the Products.

3.7 Brymec may deliver the Products by instalments, which shall be invoiced and paid for separately. Any delay in delivery or defect in an instalment shall not entitle the Customer to cancel any other instalment.

4. QUALITY

4.1 Brymec warrants that, on delivery, the Products shall conform in all material respects with their description and any applicable Specification. For products sold by weight, or in the manufacturer's packaging, Brymec may supply quantities of up to 5% more or less than the amount ordered.

4.2 Subject to 4.3 and 4.4 below, if i) the Customer gives notice in writing to Brymec within 2 business days of delivery that the Products do not comply with the Specification, and ii) Brymec is given a reasonable opportunity to examine such Products, and iii) the Customer returns such Products to Brymec's place of business at the Customer's cost, Brymec shall, at its option, replace the defective Products or refund the price of the defective Products in full.

4.3 Brymec shall not be liable for the Products' failure to comply with the warranty set out in clause 4.1 if: i) the Customer makes any further use of such Products after giving notice under 4.2 above; ii) the defect arises because the Customer failed to follow good trade practice or instructions as to the storage, commissioning, installation or use of the Products; or iii) the Customer alters or attempts to repair such Products.

4.4 Brymec may accept Product returned to it no later than 10 business days after the date of Delivery for credit or exchange, provided that the correct delivery details are provided. In this case, Brymec may make a charge for handling and restocking equal to 25% of the price of the returned Products.

4.5 Non-stock Products purchased by Brymec at the Customer's request are non-returnable and non-refundable.

4.6 Other than as set out above, Brymec shall have no liability to the Customer in respect of the Products' failure to comply with the warranty set out in clause 4.1.

5. TITLE AND RISK

5.1 The risk in the Products shall pass to the Customer on completion of delivery.

5.2 Title to the Products shall not pass to the Customer until the earlier of: i) Brymec receives payment in full for the Products; and ii) the Customer resells the Products, in which

Terms of Business

case title to the Products shall pass to the Customer at the time specified in 5.4 below.

5.3 Until title to the Products has passed to the Customer, the Customer shall store the Products separately from all other products held by the Customer so that they remain readily identifiable as Brymec's property, maintain the Products in satisfactory condition, and keep them insured against all risks for their full price from the date of delivery.

5.4 The Customer may use or resell the Products before Brymec receives payment for the Products, in which case it does so as principal and not as Brymec's agent, and title to the Products shall pass from Brymec to the Customer immediately before the time at which such reuse or resale by the Customer occurs.

6. PRICE AND PAYMENT

6.1 The price of the Products shall be the price set out in the Order Acceptance issued by Brymec. Brymec may, by giving notice to the Customer at any time up to delivery, increase the price of the Products to reflect any increase in the cost of the Products that is due to i) any factor beyond Brymec's control (including foreign exchange fluctuations, increases in taxes and duties, and increases in labour, materials and other manufacturing costs), or ii) any request by the Customer to change the delivery date(s), quantities or types of Products ordered, or the Specification.

6.2 The price of the Products excludes amounts in respect of value added tax (VAT), which the Customer shall additionally be liable to pay.

6.3 Unless otherwise stated on the Order Acceptance, Brymec shall be responsible for the cost of insurance and transport of the Products to the Delivery Location.

6.4 Brymec may invoice the Customer for the Products on or at any time after the Products have been despatched.

6.5 Unless otherwise stated in the Order Acceptance, the Customer shall pay the invoice in full and in cleared funds by the end of the month following the month the invoice was dated to the bank account nominated by Brymec. Time for payment is of the essence.

6.6 The Customer must raise any invoice queries with Brymec by email to creditcontrol@brymec.com within 28 days of the invoice date. Brymec will endeavour to respond within 2 business days and to propose a resolution to the Customer within 3 working days. The Customer must communicate any non-acceptance of such resolution to Brymec within 3 business days, failing which the relevant invoice remains payable according to these Terms.

6.7 If the Customer fails to make any payment due to Brymec under the Contract by the due date for payment, then Brymec

shall be entitled to charge interest on the overdue amount at the rate of 4.0% per annum above the base rate from time to time of the Bank of England. Such interest shall accrue on a daily basis from the due date until actual payment of the overdue amount, whether before or after judgment. The Customer shall pay the interest together with the overdue amount.

6.8 The Customer shall pay all amounts due under the Contract in full without any set-off, counterclaim or deduction. Brymec may set off any amount owing to it by the Customer against any amount payable by Brymec to the Customer.

7. LIMITATION OF LIABILITY AND INSURANCE

7.1 Nothing in these Terms shall limit or exclude Brymec's liability for: (i) death or personal injury caused by its negligence; ii) fraud or fraudulent misrepresentation; iii) breach of the terms implied by section 12 of the Sale of Goods Act 1979; or defective products under the Consumer Protection Act 1987.

7.2 Subject to 7.1 above, Brymec shall under no circumstances whatsoever be liable to the Customer, whether in contract, tort (including negligence), breach of statutory duty, or otherwise, for any loss of profit, or any indirect or consequential loss arising under or in connection with the Contract; and

7.3 Brymec has obtained insurance cover in respect of its own legal liability for individual claims not exceeding £1,000,000 per claim. Therefore Brymec's total liability to the Customer in respect of all other losses arising under or in connection with the Contract, whether in contract, tort (including negligence), breach of statutory duty, or otherwise, shall in no circumstances exceed £1,000,000, and the Customer is responsible for making its own arrangements for the insurance of any excess loss.

8. UNFORESEEN EVENTS

8.1 Neither party shall be in breach of this Contract nor liable for delay in performing, or failure to perform, any of its obligations under this Contract if such delay or failure results from an Unforeseen Event. If the period of delay or non-performance continues for three months, the party not affected may terminate this Contract by giving one month's written notice to the affected party.

9. GENERAL

9.1 Assignment. The Customer may not assign, transfer, mortgage, charge, subcontract or deal in any other manner with any or all of its rights or obligations under the Contract without Brymec's prior written consent.

9.2 Confidentiality. Each party undertakes that it shall not at any time during this agreement, and for a period of 5 years after termination of this agreement, disclose to any person any confidential information concerning the business, affairs,

Terms of Business

customers, clients or suppliers of the other party, except as permitted by this paragraph. Each party may disclose the other party's confidential information: (i) to its employees, officers, representatives or advisers who need to know such information for the purposes of carrying out its obligations under or in connection with the Contract; and (ii) as may be required by law. No party shall use any other party's confidential information for any purpose other than to exercise its rights and perform its obligations under or in connection with this agreement.

9.3 Entire agreement. This Contract constitutes the entire agreement between the parties and supersedes and extinguishes all previous agreements and understandings between them, whether written or oral, relating to its subject matter. Each party agrees that it shall have no remedies in respect of any statement, representation, assurance or warranty (whether made innocently or negligently) that is not set out in this agreement.

9.4 Variation. No variation of this Contract shall be effective unless it is in writing and signed by the parties (or their authorised representatives).

9.5 Third party rights. No one other than a party to this Contract shall have any right to enforce any of its terms.

9.6 Law and jurisdiction. The Contract, and any dispute or claim arising out of or in connection with it shall be governed by and construed in accordance with the law of England and Wales. Each party agrees that the courts of England and Wales shall have exclusive jurisdiction to settle any dispute or claim arising out of or in connection with this Contract.

10. DEFINITIONS:

10.1 Brymec: Brymec Limited, whose registered office is at Unit C, Redlands, Coulsdon, Surrey, CR5 2HT.

10.2 Terms: the terms set out in this document.

10.3 Contract: the contract between Brymec and the Customer for the sale and purchase of the Products in accordance with these Terms.

10.4 Customer: the business or person who purchases the Products from Brymec.

10.5 Delivery Location: the location for delivery of the Products set out in the Order Acceptance, or such other location as the parties may agree.

10.6 Order Acceptance: a form issued by Brymec in response to a Customer's order for Products, specifying Product details, quantities, prices and costs of transportation.

10.7 Products: the products (or any part of them) set out in the Order Acceptance.

10.8 Signed For: a Customer requirement stated in the Order Acceptance that a delivery of Product must be signed for at the Delivery Location.

10.9 Specification: any specification for the Products set out on Brymec's website or in its catalogue.

10.10 Unforeseen Event: an event or circumstance beyond a party's reasonable control.

➤ Quality Policy

Brymec Ltd (the 'Organisation') aims to provide defect free products and services to its customer on time and within budget.

The Organisation operates a Quality Management System that has gained BS EN ISO 9001 : 2015 certification, including aspects specific to the stockholding and supply of mechanical, plumbing and air conditioning products and services.

This gives us a platform to guarantee a structured approach to our continuous improvement cycle, and ensure we continue to meet and exceed the following key goals:

- Excellence of service to our customers, delivering on site, in full, on time; in the relentless pursuit of total customer satisfaction.
- Offering quality products and systems. We work with worldwide manufacturing plants (in line with our social and ethical policy) to source the best products for the UK market. We ensure that the products are fit for purpose and comply with the relevant approvals and standards. We also research and develop innovative solutions which will add value to our customers, developers and end users
- To motivate, engage and continuously develop our team by providing training, coaching, knowledge sharing and investment to ensure their absolute competence.
- To continue to invest in technology, working to understand customers' needs and streamline their buying processes to maximise efficiencies via modern technology.

This quality policy is endorsed and regularly reviewed by our Senior Management Team, and its scope is communicated to all Brymec employees via our website and other appropriate methods.

Our vision is to become an essential and indispensable supplier to the Building Services Contractor by providing excellence of service, quality products and continually investing in technology.

In order to achieve our vision, we ensure Brymec is an organisation where people love to work, upholding our core values of excellence, courage and collaboration to actively engage our team in contributing towards providing the highest level of customer satisfaction.

Luke Reiner

Managing Director

➤ Ethical Global Procurement Policy

ETHICAL POLICY - SOURCING

At Brymec we recognise the importance of credibility, integrity and trustworthiness in our success as a business. We are committed to upholding high ethical standards in all our operations, everywhere in the world. We believe in the principles of honesty, fairness, and respect for individual and community freedoms. The ethics of our UK operations are demonstrated through responsible:

- Business processes
- Corporate governance
- Custom and practice
- Quality management
- Safe working practices
- Corporate social responsibility
- Facility management
- Equality and diversity
- Anti-bribery and corruption
- Employee care

The Ethical Trading Initiative Code forms the basis of this policy

Additionally, as we expand our network of suppliers to source products globally, it is increasingly necessary to ensure that the organisations that we undertake business with also meet our expectations of standards of supply.

As a minimum Brymec Ltd expects its supply partners to comply with all local laws and regulations and to respect internationally recognised human and labour rights as well as international initiatives for climate change.

In particular we require that suppliers ensure:

- Working hours and remuneration are reasonable and meet the required local wage and working time laws
- Working conditions are safe and hygienic
- No discrimination is practised
- Employment is freely chosen
- Children are not employed, and local minimum age rules are in place
- Freedom of Association and the right to collective bargaining are respected
- No improper advantage, including the payment of bribes.
- Packaging and waste are subject to recycling and safe disposal guidelines
- That all sourcing of materials and manufacturing processes are subject to sustainability and renewability rules

Brymec carry out initial assessments and, on agreeing terms of business, provide the criteria against which the company has been measured by way of regulating ongoing requirements.

Brymec then carry out periodic on-site audits to ensure that compliance is maintained.

Brymec will work with its suppliers to guide and advise them in maintaining and improving required levels of environmental standards.

The Brymec Sourcing Director has responsibility for this policy and will report to the management meetings on any issues arising.

A copy of the full Ethical trading initiative can be found at www.ethicaltrade.org.

Brymec 



CO₂e
Assessed
Organisation

brymec.com

2023-V1.0