

Brymec 

**Malleable Iron
Technical Manual 2023**





Contents

Introducing Brymec Products	4
Environmental Model	5
Introducing the Brymec Malleable Iron Fittings Range	6
Technical Information	8
Applications	10
Fittings Specifications	11
Part 2 Tube Specifications	12
Tube & Fittings Threads	14
Linear Pipe Expansion	17
Flange Chart	17
Gasket Specifications	18
Product Range	19
Technical Support	44
Warranty	45
Terms of Business	46
Quality Policy	49
Ethical Procurement Policy	50

➤ Introducing Brymec Products

Our philosophy has always been to provide the ultimate convenience and peace of mind to our clients. This also includes ensuring that you have the best possible products to select from.

By investing in innovation, we have been able to engineer our own range of products, all manufactured to our exacting specifications to deliver quality solutions for the Building Services Industry.

Every one of our Brymec products is manufactured to the highest quality standards possible and are backed up by our in-house technical support, robust quality controls and industry-leading guarantees.

Our innovative approach simplifies your supply chain, giving you direct access to the manufacturer. This gives you greater control and confidence in Brymec being the right partner for you.

With almost 50 years of experience, we understand the challenges you face and the solutions you require.

This complete understanding of industry products and systems enable us to collaborate with you more effectively and efficiently, to deliver a more comprehensive range of products that are specific to your needs.





➤ Our 3 Step Approach to an **Environmentally Friendly Build...**

Brymec cuts down the movement of products, which cuts the impact to the environment

This helps our customers reduce their carbon footprint of the products they buy from us

Traditional 6 Step Model

- | | | |
|---------------------------------|-------------------------|---------------------|
| 1 Manufacturer | 2 European Distribution | 3 UK Distribution |
| 4 Merchant Central Distribution | 5 Branches | 6 Construction Site |

Our Environmentally Friendly Business Model

1. Factory

2. Brymec

3. Construction Site

➤ Introducing the Brymec Malleable Iron Fittings range

Our Malleable Iron range has been carefully designed and selected to meet the highest quality standards. Brymec's high quality malleable iron fittings and tube will guarantee you a corrosion resistant, long lasting piping system.

The comprehensive range of fitting configurations are produced in compliance with EN 10242 Design Symbol "A".

Our malleable iron fittings are exclusively manufactured from blackheart malleable iron type EN-GJMB-350-10 and with Rp and R jointing threads. Our malleable range is also fully compliant with the Pressure Equipment Directive.

Our male taper to female parallel thread ensures total seal and positive tightening, offering a substantial pressure seal on the joint.

Typical applications include closed circuit heating systems, fire suppression systems, Natural gas and LPG, and compressed air.





Applications

Malleable cast iron fittings are used for conveying liquids and gases up to the pressure and temperature limits specified in standard ISO49 and EN 10242. Typical applications include:

- › Chilled/Heating systems
- › Spinkler Systems
- › Natural Gas and LPG
- › Compressed Air
- › Hot water & steam

The following working temperatures and pressures apply to Brymec malleable cast iron range:

Working Temperature (°C)	Max Working Pressure (Bar)
-20 to 120	25
From 120 up to 300	Interpolated Values
300	20

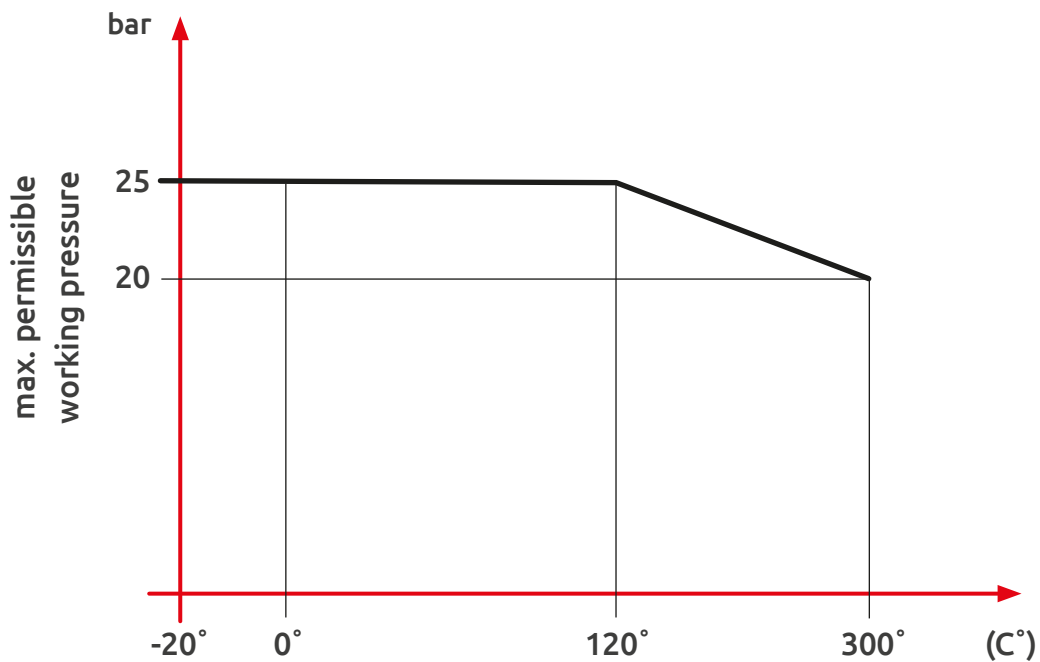

Fittings Specifications

The Brymec range of Malleable Cast iron fittings are manufactured from blackheart malleable cast iron type EN-GJMB-350-10 with internal parallel threads (Rp) and external tapered threads (R) compliant with the Pressure Equipment Directive (PED).

Our fittings are manufactured in accordance with the international fittings standard ISO 49 and the European malleable cast iron fittings standard EN 10242. The different grades of malleable cast iron and jointing threads within EN 10242 and ISO49 are grouped into 'Design Symbols'. These 'Design Symbols' have been introduced to enable specifiers and installers to ensure the correct fittings are being used. Brymec malleable cast iron fittings comply with Design Symbol A.

Design Symbols for malleable cast iron fittings:

Design Symbol	Type of material acc. to EN 1562	Tensile strength (N/mm ²)	Elongation (%)	Jointing Thread	
A	EN-GJMW-400-5	400	5	Parallel internal thread Rp and taper external thread R acc. To EN 10226-1/ISO7-1	
	EN-GJMB-350-10	350	10		
B	EN-GJMW-350-4	350	4		
	EN-GJMB-300-6	300	6		
C*	EN-GJMW-400-5	400	5		Taper internal thread Rc* and taper external thread R acc. To EN 10226-2/ISO 7-1
	EN-GJMB-350-10	350	19		
D*	EN-GJMW-350-4	350	4		
	EN-GJMB-300-6	300	6		

*Not used in Continental Europe, partially prohibited by national regulations.

Fittings Specifications (continued)

Material – Malleable Cast Iron

Malleable cast iron is an iron-carbon alloy which combines the outstanding properties of cast iron (pourability) and steel (strength and ductility). The chemical composition of the cast iron produces excellent castability, which makes malleable cast iron particularly suitable for making complicated shapes and producing thin-walled parts. In its cast state malleable cast iron is hard, brittle and unworkable, it only acquires its final microstructure after subsequent heat treatment known as annealing. As a result of the annealing process, very good workability and very good ductility are achieved while sufficiently high material strength is maintained.

Hot Dip Galvanising

Galvanising is a very commonly used process for increasing the corrosion resistance of iron based materials. The corrosion proofing effect of zinc is based on its anticorrosive properties. Zinc is in fact a relatively base metal and corrodes quickly in the presence of oxygen, but in the process it forms a very homogeneous outer layer, which protects from further corrosion. Hot dip galvanising achieves a zinc coating by repeatedly dipping the prepared workpieces in molten zinc bath. In the process, several iron-zinc alloy layers form on the workpiece surface which guarantee optimal bonding of zinc coating on the workpiece. Brymec Galvanised malleable cast iron fittings are hot dip galvanized to the requirements of EN 10242, using special procedural technique ensuring that uniform coating thicknesses (minimum 500g/m² equivalent to 70 µm) is achieved.

Part 2 Tube Specifications

Selecting the correct pipework is of utmost importance to ensure compliance with current regulations and to minimise the risk of failure. Brymec stock steel tube that is compliant with the latest regulations. Our carbon steel tubes are manufactured in accordance with the standards set out in EN10217-2 and EN10255 to satisfy both the Pressure Equipment Directive (PED) and the Construction Products Regulations (CPR), suitable for high temperature building and industrial installations.

Technical Specifications:

Standards - BS EN 10255 / 10217-2:2019 GH Part 2 - TC 1

Technical Delivery Condition	Hot Finished (Full Body Normalising)
Material Grade	S195T-P235GH
Temperature Classification	High Temperature (HT) -20°C to 300°C
PED Compliance	Yes
CPR CE Compliance	Yes - Category 3 (Fuel, Air & Gas) & Category 4 (water)
UKCA Compliance	Yes
TUV Certified	Yes

Tube Dimensions for Heavy weight:

Size (inch)	Size (mm)	Outside Diameter (mm)	Wall Thickness (mm)	Dry Weight (Kg/m)	Wet Weight (Kg/m)
1/2"	15	21.3	3.2	1.4	1.6
3/4"	20	26.9	3.2	1.9	2.2
1"	25	33.7	4.0	2.9	3.5
1 1/4"	32	42.4	4.0	3.8	4.7
1 1/2"	40	48.3	4.0	4.4	5.7
2"	50	60.3	4.5	6.2	8.3
2 1/2"	65	76.1	4.5	7.9	11.5
3"	80	88.9	5.0	10.3	15.2
4"	100	114.3	5.4	14.5	23.0

Chemical Compositions and Mechanical Properties:

Our carbon steel Part 2 compliant tubes are suitable for design temperatures from - 20°C to 300°C, with guaranteed elevated temperature properties. Our tubes conform to the requirements in the below tables, and are tested and inspected to ensure compliance with both BS EN 10255 and EN 10217-2.

Steel Grade S195T/P235GH:

Chemical Compositions				Mechanical Properties						
Max %				Mpa		Min %		Min Joule		
C Carbon	Mn Manganese	P Phosphorus	S Sulphur	Yield (min)	Tensile (min-max)	Elongation		Impact Energy		
0.16	1.2	0.025	0.020	235	360-500	L 25	T 23	L (0°) 40	L (-10°) 28	T (0°) 27

L: Longitudinal T: Transverse

Chemical Compositions and Mechanical Properties:

The below table details the maximum design pressures for our **Heavy weight** Part 2 complaint carbon steel tubes. Note that Screwed and Socketed joints must be made using suitable and appropriate jointing compounds and butt-welded joints must be prepared in accordance with current best practices.

	Tube Sizes inch/mm (Nb)										
	1/2	3/4	1	1 1/4	1 1/2	2	2 1/2	3	4	5	6
	15	20	25	32	40	50	65	80	100	125	150
	Pressure (bar)										
Water -20 to 100°C	100	90	85	70	60	55	45	40	35	N/A	N/A
Compressed Air	90	80	75	65	55	50	40	35	30	N/A	N/A
Steam to 220°C Max	22	22	22	21	21	19	19	19	17	N/A	N/A
-20 to 60°C	270	215	215	171	150	136	108	103	86	70	60
100°C Max	234	187	186	148	130	118	93	89	75	61	52
150°C Max	225	179	179	143	125	113	90	85	72	59	50
300°C Max	158	126	126	100	88	80	63	60	51	41	35

▶ Tube & Fittings Threads

Overview

There are international and national standards that determine threads for valves, pipes and fittings used within the building services industry. These can be divided into two categories:

- ▶ **Joining Threads** – Threads made to the standard ISO 7/1, where a pressure tight seal is created on the thread itself as a result of the compression between the interlocking taper/parallel threads. The joint seal is enhanced with the juice of a suitable jointing paste and hemp, sealing strips or other materials.
- ▶ **Fastening Threads** – Threads made according to the standard ISO 228/1. In contrast to a joining thread, a fastening thread is purely a mechanical joint where a seal is created between the two components by using a flat seal gasket.

Malleable Fitting and Steel Tube Threads to ISO 7/1

The ISO7/1 thread profile on Brymec malleable fittings ensures a pressure tight joint. The internal parallel to external tapered pipe thread joint is so defined that the sealing takes place mainly by compressing metal on metal. The sealing material has only the task of equalising small irregularities of the thread surface. In creating a pressure tight joint, a suitable sealing paste with hemp or a sealing tape should be used to ensure a complete seal.

Internal Threads:

The internal threads on Brymec fittings are a parallel thread as per Fig.1. The fittings have a thread length (L2) that allows the external thread to screw in completely until compression and sealing are sufficient, even when the allowable gauge length is at its maximum value.

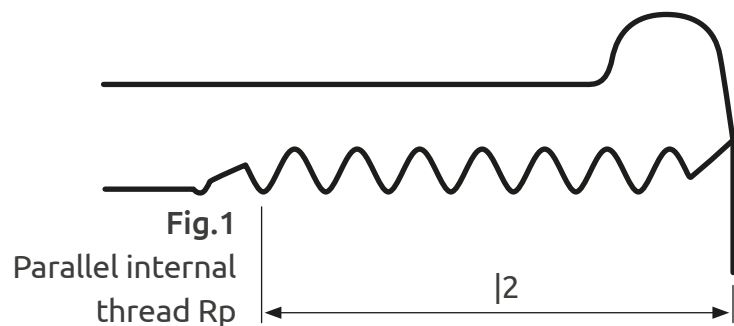

External Threads:

External threads on both Brymec Fittings and steel tube are a parallel thread as per Fig.2. The taper external thread is cut to a ratio of 1:16.

The total thread length is divided into 2 sections as show in Fig. 2:

- ▶ The distance "a" of the gauge plane is laid out in such a way that the external thread can be easily screwed in, even into smallest internal thread and that the sealing material will be drawn into the joint.

- The “b” dimension is the portion of the thread where the sealing between the two components is made. This thread portion behind the gauge plane has fully formed roots, and its length is designed to ensure a sufficient tightening path, even at maximum allowable internal thread diameter, creating a strong and leak proof compression between the internal parallel thread and external taper thread.
- The “c” dimension is the washout thread which means that the last 1 or 2 threads with partially formed and incomplete roots remain visible. If the external thread is screwed into too far so that washout threads are no longer visible, there is a potential risk of stress cracking and leakage.

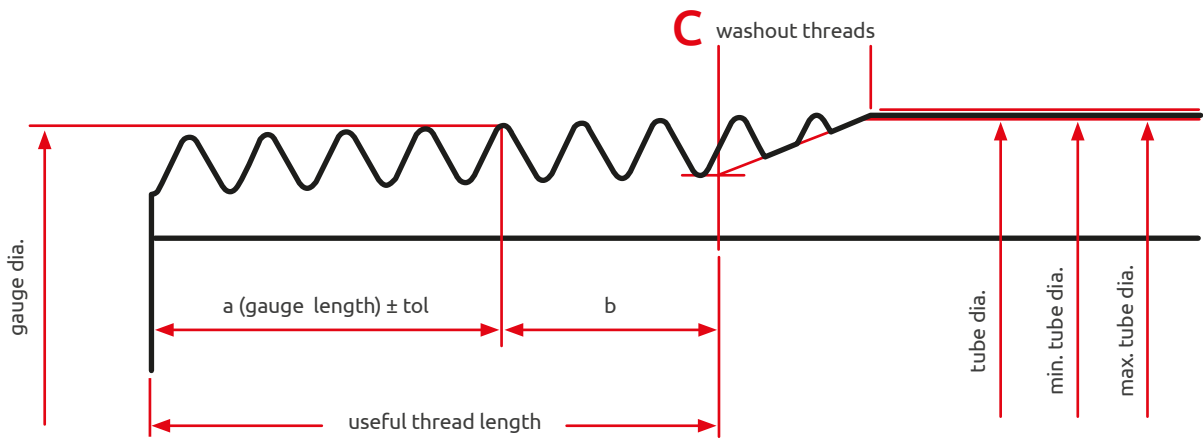
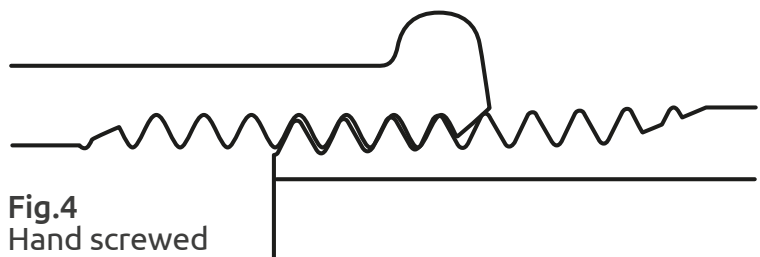

Fig.2 Taper external thread on steel tube and male malleable fittings.

The tube outside diameter is normally large enough so that the crests of the threads can be fully formed along the useful thread length (A+B) as illustrated in Fig. 2 when the thread is being cut. Even if the tube outside diameter is at the minimum allowable tolerance, the crests will still be fully formed beyond the gauge plane, which ensures no gap can arise between the internal and external threads. The joint between the pipe and fitting is so defined that the sealing is mainly created by compressing metal on metal. The joint sealant such as hemp and paste is used to seal the potential small irregularities on the thread surface.

Fig.4 illustrates when a fitting is hand tightened on to a tube thread. There will be between 2 ¾ to 4 ½ turns of external thread left to be tightened using a wrench.



▶ Tube & Fittings Threads (continued)

Once the fitting is hand tightened, the joint needs to be tightened using a wrench for between 2 ¾ to 4 ½ turns as per the below table.

Thread Size	1/4"	3/8"	1/2"	3/4"	1"	1 1/4"	1 1/2"	2"	2 1/2"	3"	4"
Hand Screwed length (mm)	6	6	8	10	10	13	13	16	18	21	26
Tool tightened length in number of turns	2 3/4	2 3/4	2 3/4	2 3/4	2 3/4	2 3/4	2 3/4	3 1/4	4	4	4 1/2
Average length of engagement	10	10	13	15	17	19	19	24	27	30	36

Fig. 5 below illustrates the thread connection tightened with a wrench according to the standard. It can be screwed a little more or little less, to adjust the outlet direction of the fitting without compromising the integrity of the leak proof joint.

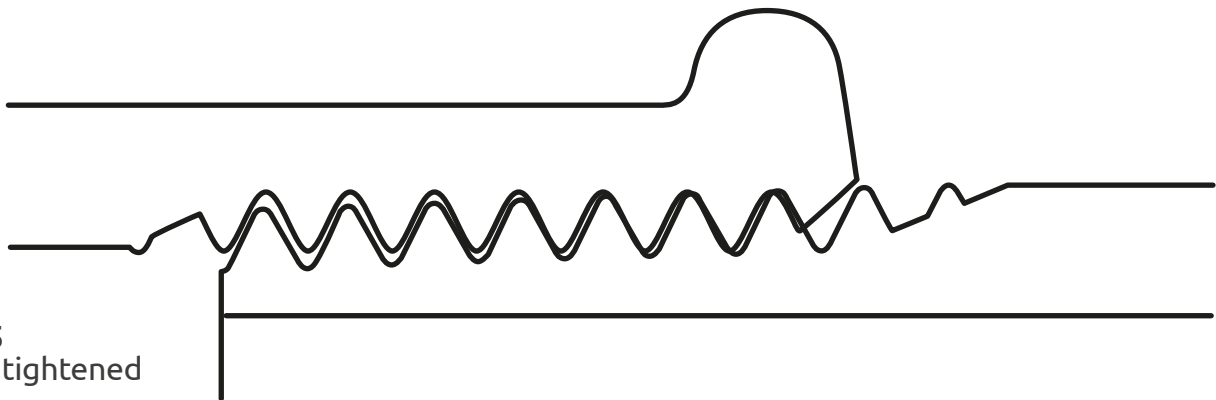

Fig.5
Tool tightened

Linear Pipe Expansion

Changes in temperature cause pipework systems to expand and contract to different degrees depending on the temperature and material differences. It is of key importance that this thermal movement is considered when designing and installing pipework systems. Fixing pipework too rigidly, can restrict the natural expansion that comes from thermal fluctuations, causing mechanical stress and tension and compromise the integrity of joints.

The heat expansion co-efficient in steel pipelines can be calculated with the below formula:

$$\Delta L = L * \alpha * \Delta T$$

Whereby:

ΔL = total extension in mm.

L = length of the pipe in m.

α = Linear expansion coefficient ($\alpha = 0.012$ mm/m for steel pipelines).

ΔT = Temperature fluctuation in °K.

The following table can be used to calculate the thermal extension of carbon steel pipelines:

Change in Length ΔL (mm) for carbon steel pipelines with temperature difference Δt °C										
Pipe Length (m)	$\Delta t=10^\circ$	$\Delta t=20^\circ$	$\Delta t=30^\circ$	$\Delta t=40^\circ$	$\Delta t=50^\circ$	$\Delta t=60^\circ$	$\Delta t=70^\circ$	$\Delta t=80^\circ$	$\Delta t=90^\circ$	$\Delta t=100^\circ$
1	0.12	0.24	0.36	0.48	0.60	0.72	0.84	0.96	1.08	1.20
2	0.24	0.48	0.72	0.96	1.20	1.44	1.68	1.92	2.16	2.40
3	0.36	0.72	1.08	1.44	1.80	2.16	2.52	2.88	3.24	3.60
4	0.48	0.96	1.44	1.92	2.40	2.88	3.36	3.84	4.32	4.80
5	0.60	1.20	1.80	2.40	3.00	3.60	4.20	4.80	5.40	6.00
6	0.72	1.44	2.16	2.88	3.60	4.32	5.04	5.76	6.48	7.20
7	0.84	1.68	2.52	3.36	4.20	5.04	5.88	6.72	7.56	8.40
8	0.96	1.92	2.88	3.84	4.80	5.76	6.72	7.68	8.64	9.60
9	1.08	2.16	3.24	4.32	5.40	6.48	7.56	8.64	9.72	10.80
10	1.20	2.40	3.60	4.80	6.00	7.20	8.40	9.60	10.80	12.00
15	1.80	3.60	5.40	7.20	9.00	10.80	12.60	14.40	16.20	18.00
20	2.40	4.80	7.20	9.60	12.00	14.40	16.80	19.20	21.60	24.00

The basic principle is that there must always be adequate capacity for expansion between two fixed points.

The inherent elasticity of the pipework can often be used to compensate for expansion, however wherever there is a change in pipework direction it is necessary to arrange pipe clamps to provide sufficiently flexible pipe limbs.

Flange Sizing Table

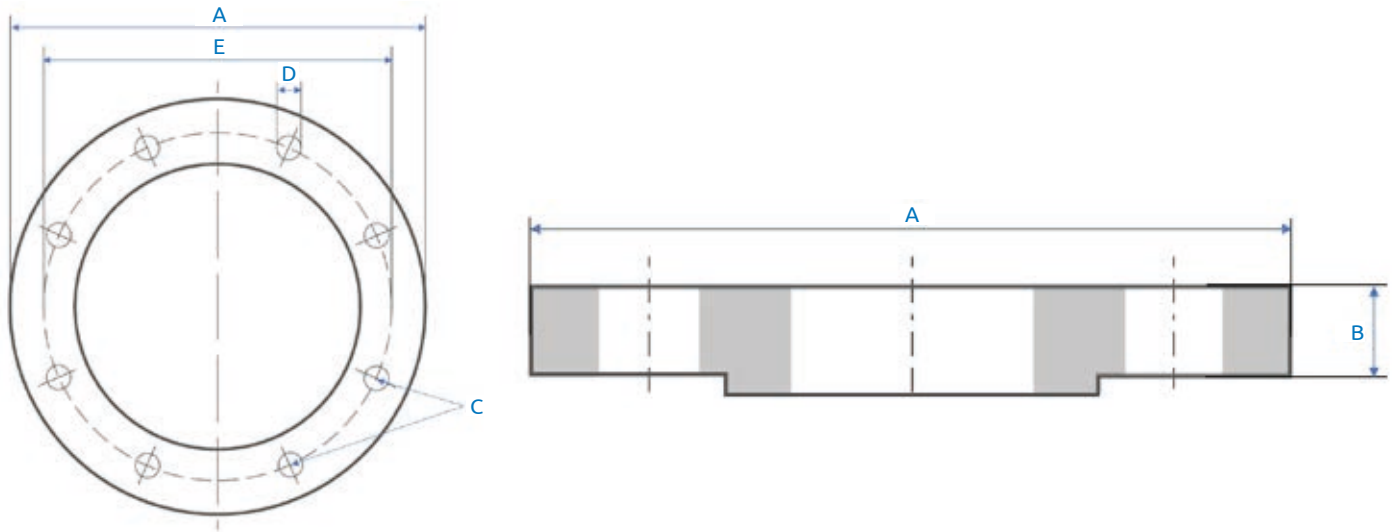

Nominal Bore	Nominal Bore mm	Pressure Rating	Flange Dia A (mm)	Thickness B	Length & Dia of Bolts	No of Holes C	Dia of Holes D (mm)	PCD E (mm)
1/2"	DN15	PN6	80	12	M10 x 50	4	11	55
		PN10	95	14	M12 x 55	4	14	65
		PN16	95	14	M12 x 55	4	14	65
3/4"	DN20	PN6	90	14	M10 x 55	4	11	65
		PN10	105	16	M12 x 60	4	14	75
		PN16	105	16	M12 x 60	4	14	75
1"	DN25	PN6	100	14	M10 x 55	4	11	75
		PN10	115	16	M12 x 60	4	14	85
		PN16	115	16	M12 x 60	4	14	85
1 1/4"	DN32	PN6	120	14	M12 x 55	4	14	90
		PN10	140	16	M16 x 60	4	18	100
		PN16	140	16	M16 x 60	4	18	100
1 1/2"	DN40	PN6	130	14	M12 x 55	4	14	100
		PN10	150	16	M16 x 60	4	18	110
		PN16	150	16	M16 x 60	4	18	110
2"	DN50	PN6	140	14	M12 x 55	4	14	110
		PN10	165	18	M16 x 60	4	18	125
		PN16	165	18	M16 x 60	4	18	125
2 1/2"	DN65	PN6	160	14	M12 x 55	4	14	130
		PN10	185	18	M16 x 60	4	18	145
		PN16	185	18	M16 x 60	4	18	145
3"	DN80	PN6	190	16	M16 x 60	8	18	150
		PN10	200	20	M16 x 65	8	18	160
		PN16	200	20	M16 x 65	8	18	160
4"	DN100	PN6	210	16	M16 x 60	8	18	170
		PN10	220	20	M16 x 70	8	18	180
		PN16	220	20	M16 x 70	8	18	180

Gasket Specifications

Our flange gaskets are I.B.C (Inner Bolt Circle) style gaskets, otherwise known as ring-type or raised-faced, and sit inside the ring of bolts which fasten the pipe flanges.

Specification:

- › Designed to BS EN 1514-1:1997 standard
- › Material is asbestos free, to BS7531 standard. Novus 30
- › WRAS approved
- › Thickness 1.5mm,
- › Pressure rated PN16
- › Max Temperature 200°C
- › Max Pressure 40 Bar
- › Density 2.0g/cc
- › Tensile Strength 12Mpa - ASTM F152
- › Compression 9% - ASTM F36

We recommend the following best practices to ensure correct gasket fitting:

- › Check the gasket is in good condition
- › Clean the flange faces and remove any dirt on the studs / bolts /nuts
- › Do not use jointing compounds in assembly
- › Lubricate the threads and the nut face only, NOT the flange or gasket faces
- › Before assembly ensure that the nuts run freely on the threads
- › Carefully fit the gasket taking care not to damage the gasket surface
- › Tighten the bolts in the recommended sequence (e.g. diametrically opposite) to about half load
- › Check visually that the flanges are uniformly loading the gasket
- › Tighten to the recommended torque for the flange system
- › After 24 hours of operation, or one process cycle, re-tighten to the correct torque (the gasket will have relaxed)
- › If the flange has not been in service and is unlikely to be so in the short term, then still re-tighten



Product Range

▶ Part 2 - Hot Form Heavy Weight - Screwed and Socketed



STOCK NO	Size (Inch)	Size (mm)	Nominal Length (m)
400242	1/2"	15	3.25
400252	3/4"	20	3.25
400262	1"	25	3.25
400272	1 1/4"	32	3.25
400282	1 1/2"	40	3.25
400292	2"	50	3.25
400302	2 1/2"	65	3.25
400312	3"	80	3.25
400322	4"	100	3.25

6.5 metre lengths available

▶ Heavy Weight Galvanised Steel Tube - Screwed and Socketed*



STOCK NO	Size (Inch)	Size (mm)	Length (m)
406040	1/2"	15	3.25
406050	3/4"	20	3.25
406060	1"	25	3.25
406070	1 1/4"	32	3.25
406080	1 1/2"	40	3.25
406090	2"	50	3.25
406110	3"	80	3.25
406120	4"	100	3.25

*Lead times may apply

➤ Flange Range

➤ Threaded Flange PN16 Type 113 (16/4)



STOCK NO	Size (Inch)	Size (mm)
405130	1/2"	15
405150	1"	25
405160	1 1/4"	32
405170	1 1/2"	40
405180	2"	50
405190	2 1/2"	65
405200	3"	80
405210	4"	100

➤ Galvanised Threaded Flange PN16 Type 113 (16/4)



STOCK NO	Size (Inch)	Size (mm)
410340	1"	25
410350	1 1/4"	32
410360	1 1/2"	40
410370	2"	50
410380	2 1/2"	65
410390	3"	80
410400	4"	100

➤ Blanking Plate PN16 Type 105 (16/8)



STOCK NO	Size (Inch)	Size (mm)
50249	2"	50
50250	2 1/2"	65
50251	3"	80
50252	4"	100

➤ IBC Ring Gaskets PN16



STOCK NO	Size (Inch)	Size (mm)
38780	1/2"	15
38781	3/4"	20
38782	1"	25
38783	1 1/4"	32
38784	1 1/2"	40
38785	2"	50
38786	2 1/2"	65
38787	3"	80
38788	4"	100

➤ **Black Malleable Fittings**

Equal Sockets

176/271/M2 R-L

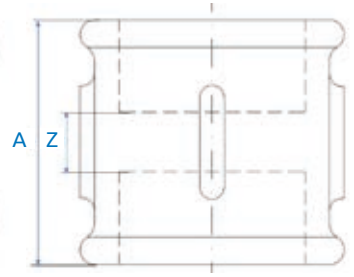

STOCK NO	Size (Inch)	DIM A (mm)	DIM Z (mm)
420000	1/2"	36	10
420001	3/4"	39	9
420002	1"	45	11
420003	1 1/4"	50	12
420004	1 1/2"	55	17
420005	2"	64	17
420006	2 1/2"	74	20
420007	3"	80	20
420008	4"	91	22

Concentric Reducing Sockets

179/210/M2

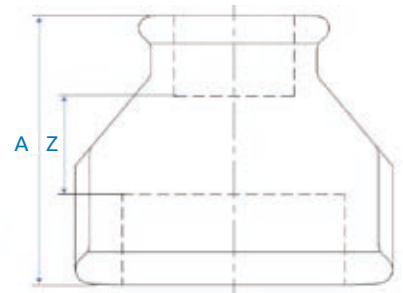

STOCK NO	Size (Inch)	DIM A (mm)	DIM Z (mm)
420023	1/2 x 3/8"	36	13
420024	3/4 x 3/8"	39	14
420025	3/4 x 1/2"	39	11
420026	1 x 1/2"	45	15
420027	1 x 3/4"	45	13
420029	1 1/4 x 3/4"	50	16
420030	1 1/4 x 1"	50	14
420031	1 1/2 x 1/2"	55	23
420032	1 1/2 x 3/4"	55	21
420033	1 1/2 x 1"	55	19
420034	1 1/2 x 1 1/4"	55	17
420028	1 1/4 x 1/2"	50	18
420040	2 1/2 x 1 1/2"	74	28
420041	2 1/2 x 2"	74	23

Concentric Reducing Sockets (Continued)

179/210/M2

STOCK NO	Size (Inch)	DIM A (mm)	DIM Z (mm)
420035	2 x 1/2"	65	28
420036	2 x 3/4"	65	26
420037	2 x 1"	65	24
420038	2 x 1 1/4"	65	22
420039	2 x 1 1/2"	65	22
420042	3 x 2"	80	26
420043	3 x 2 1/2"	80	23

Eccentric Reducing Sockets

180/260/M3

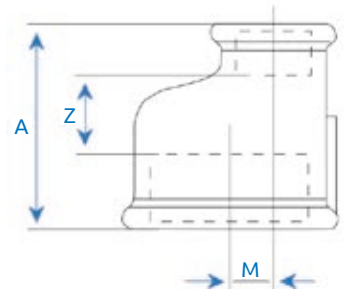

STOCK NO	Size (Inch)	DIM A (mm)	DIM Z (mm)	DIM M (mm)
420009	3/4 x 1/2"	41	13	3
420010	1 x 1/2"	45	15	6
420011	1 x 3/4"	45	13	3.5
420012	1 1/4 x 1/2"	50	18	11
420013	1 1/4 x 3/4"	50	16	8
420014	1 1/4 x 1"	50	14	5
420015	1 1/2 x 3/4"	56	22	11
420016	1 1/2 x 1"	56	20	8
420017	1 1/2 x 1 1/4"	56	18	3
420018	2 x 1/2"	65	28	20
420020	2 x 1"	65	24	14
420021	2 x 1 1/4"	65	22	10
420022	2 x 1 1/2"	65	22	7

▶ F X F Twin 90° Elbows

197/132/E2

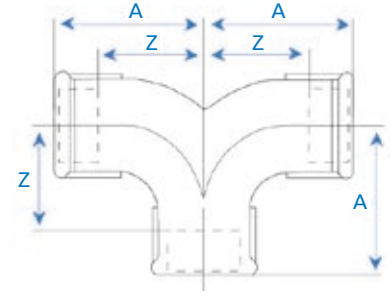

STOCK NO	Size (Inch)	DIM A (mm)	DIM Z (mm)
420154	1/2"	45	32
420155	3/4"	50	35
420156	1"	63	46
420157	1 1/4"	76	57
420158	1 1/2"	85	66
420159	2"	102	78

▶ F X F 90° Elbows

151/90/A1

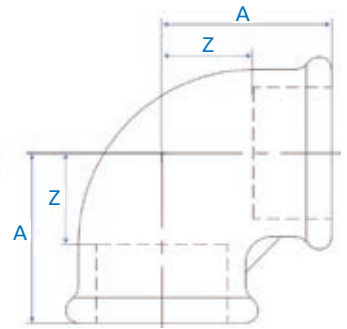

STOCK NO	Size (Inch)	DIM A (mm)	DIM Z (mm)
420060	1/2"	28	15
420061	3/4"	33	18
420062	1"	38	21
420063	1 1/4"	45	26
420064	1 1/2"	50	31
420065	2"	58	34
420066	2 1/2"	69	42
420067	3"	78	48
420068	4"	96	60

➤ M X F 90° Elbows

152/92/A4

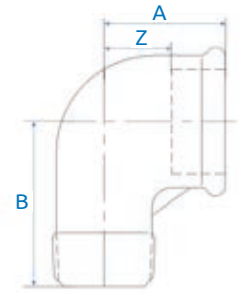

STOCK NO	Size (Inch)	DIM A (mm)	DIM B (mm)	DIM Z (mm)
420350	1/2"	28	37	15
420351	3/4"	33	43	18
420352	1"	38	52	21
420353	1 1/4"	45	60	26
420354	1 1/2"	50	65	31
420355	2"	58	74	34
420356	2 1/2"	69	88	42
420357	3"	78	98	48
420358	4"	96	118	60

➤ F X F 45° Elbows

155/120/A1-45

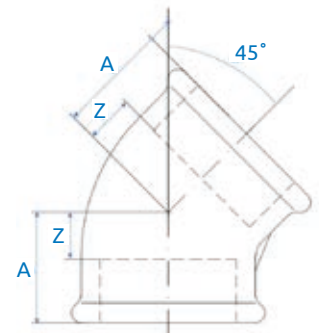

STOCK NO	Size (Inch)	DIM A (mm)	DIM Z (mm)
420077	1/2"	22	9
420078	3/4"	25	10
420079	1"	28	11
420080	1 1/4"	33	14
420081	1 1/2"	36	17
420082	2"	43	19
420083	2 1/2"	48	21
420084	3"	54	24

M X F 45° Elbows

156/121/A4-45

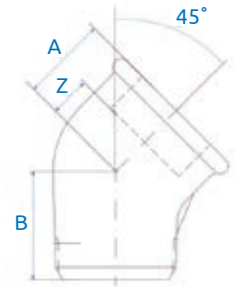

STOCK NO	Size (Inch)	DIM A (mm)	DIM B (mm)	DIM Z (mm)
420360	1/2"	22	28	9
420361	3/4"	25	32	10
420362	1"	28	37	11
420363	1 1/4"	33	43	14
420364	1 1/2"	36	46	17
420365	2"	43	55	19

F X F 90° Short Bends

193/2A/D1

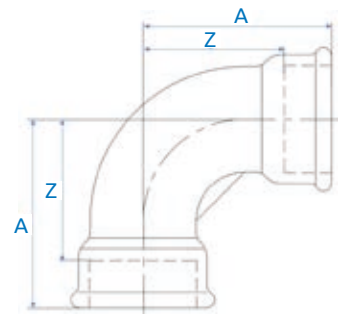

STOCK NO	Size (Inch)	DIM A (mm)	DIM Z (mm)
420044	1/2"	45	32
420045	3/4"	50	35
420046	1"	63	46
420047	1 1/4"	76	57
420048	1 1/2"	85	66
420049	2"	102	78
420050	2 1/2"	119	92
420051	3"	127	97

M X F 90° Short Bends

192/1A/D4

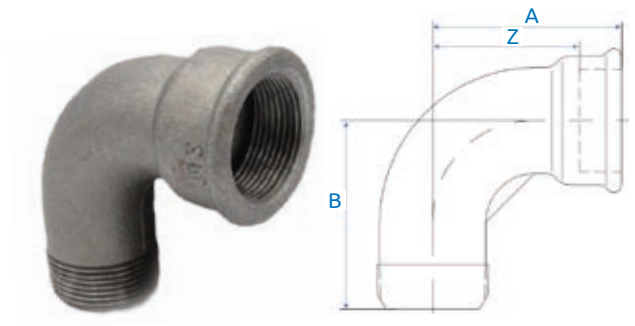

STOCK NO	Size (Inch)	DIM A (mm)	DIM B (mm)	DIM Z (mm)
420052	1/2"	45	45	32
420053	3/4"	50	50	35
420054	1"	63	63	46
420055	1 1/4"	76	76	57
420056	1 1/2"	85	85	66
420057	2"	102	102	78
420058	2 1/2"	115	115	88
420059	3"	127	127	97

M X F 90° Long Swept Bends

1/G4

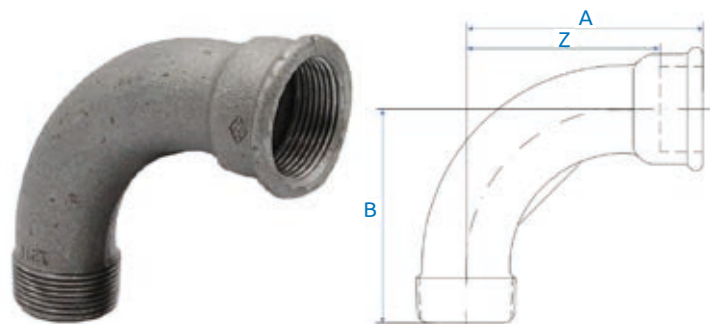

STOCK NO	Size (Inch)	DIM A (mm)	DIM B (mm)	DIM Z (mm)
420069	1/2"	55	48	42
420070	3/4"	69	60	54
420071	1"	85	75	68
420072	1 1/4"	105	95	86
420073	1 1/2"	116	105	97
420074	2"	140	130	116

➤ M X F 45° Long Swept Bends

40/G4

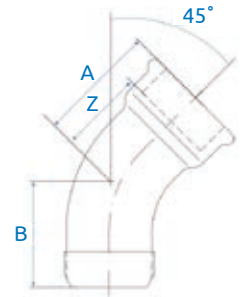

STOCK NO	Size (Inch)	DIM A (mm)	DIM B (mm)	DIM Z (mm)
420085	1/2"	36	30	23
420086	3/4"	43	36	28
420087	1"	51	42	34
420088	1 1/4"	64	54	45
420089	1 1/2"	68	58	49
420090	2"	81	70	57

➤ 90° Degree Equal Tees

161/130/B1

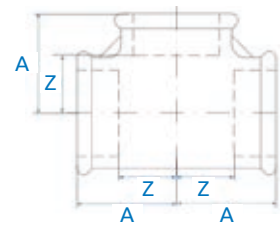

STOCK NO	Size (Inch)	DIM A (mm)	DIM Z (mm)
420093	1/2"	28	15
420094	3/4"	33	18
420095	1"	38	21
420096	1 1/4"	45	26
420097	1 1/2"	50	31
420098	2"	58	34
420099	2 1/2"	69	42
420100	3"	78	48
420101	4"	96	60

90° Degree Reducing Tees

161/130/B1

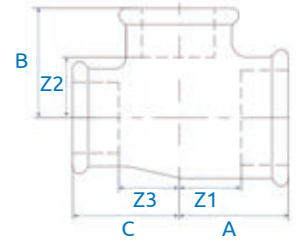

STOCK NO	Size (End x End x Centre) (Inch)	DIM A (mm)	DIM B (mm)	DIM C (mm)	DIM Z1 (mm)	DIM Z2 (mm)	DIM Z3 (mm)
420102	3/4" x 3/4" x 1/2"	30	31	30	15	18	15
420125	3/4" x 1/2" x 1/2"	30	31	30	15	18	15
420126	3/4" x 1/2" x 3/4"	30	31	30	15	18	15
420103	1" x 1" x 1/2"	32	34	32	15	21	15
420104	1" x 1" x 3/4"	35	36	35	18	21	18
420127	1" x 1/2" x 1"	32	34	32	15	21	15
420128	1" x 3/4" x 1/2"	32	34	30	15	21	15
420129	1" x 3/4" x 3/4"	35	36	33	18	21	18
420105	1 1/4" x 1 1/4" x 1/2"	34	38	34	15	25	15
420130	1 1/4" x 1/2" x 1 1/4"	34	38	34	15	25	15
420106	1 1/4" x 1 1/4" x 3/4"	36	41	36	17	26	17
420107	1 1/4" x 1 1/4" x 1"	40	42	40	21	25	21
420108	1 1/2" x 1 1/2" x 1/2"	36	42	36	17	29	17
420109	1 1/2" x 1 1/2" x 3/4"	38	44	38	19	26	19
420110	1 1/2" x 1 1/2" x 1"	42	46	42	23	29	23
420111	1 1/2" x 1 1/2" x 1 1/4"	46	48	46	27	29	27
420112	2" x 2" x 1/2"	38	48	38	14	35	14
420131	2" x 1/2" x 2"	58	58	48	34	34	35
420113	2" x 2" x 3/4"	40	50	40	16	35	16
420114	2" x 2" x 1"	44	52	44	20	35	20
420115	2" x 2" x 1 1/4"	48	54	48	24	35	24
420116	2" x 2" x 1 1/2"	52	55	52	28	36	28
420117	2 1/2" x 2 1/2" x 1/2"	41	56	41	14	43	14
420118	2 1/2" x 2 1/2" x 1"	47	60	47	20	43	20
420119	2 1/2" x 2 1/2" x 1 1/4"	52	62	52	25	43	25
420120	2 1/2" x 2 1/2" x 1 1/2"	55	63	55	28	44	28
420121	3" x 3" x 1/2"	46	63	46	15	50	15
420122	3" x 3" x 1 1/4"	55	70	55	28	44	28
420123	3" x 3" x 1 1/2"	58	71	58	28	52	28
420124	3" x 3" x 2"	64	73	64	34	49	34

Equal Pitcher Tees

199/131/E1

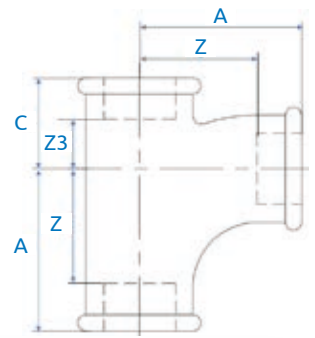

STOCK NO	Size (Inch)	DIM A (mm)	DIM C (mm)	DIM Z (mm)	DIM Z3 (mm)
420132	1/2"	45	24	32	11
420133	3/4"	50	28	35	13
420134	1"	63	33	46	16
420135	1 1/4"	76	40	57	21
420136	1 1/2"	85	43	66	24
420137	2"	102	53	78	29
420138	2 1/2"	115	62	88	35

Reducing Pitcher Tees

199/131/E1

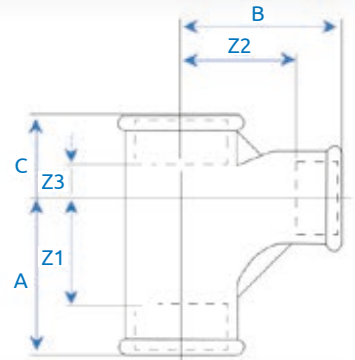

STOCK NO	Size (End x Centre x End) (Inch)	DIM A (mm)	DIM B (mm)	DIM C (mm)	DIM Z1 (mm)	DIM Z2 (mm)	DIM Z3 (mm)
420139	3/4 x 1/2"	47	48	25	32	35	10
420140	1 x 1/2"	49	51	28	32	38	11
420141	1 x 3/4"	53	54	30	36	39	13
420142	1 1/4 x 1/2"	51	56	30	32	42	11
420143	1 1/4 x 3/4"	55	58	33	36	43	14
420144	1 1/4 x 1"	66	68	36	47	51	17
420145	1 1/2 x 1/2"	52	58	29	33	45	10
420146	1 1/2 x 3/4"	55	61	33	36	46	14
420147	1 x 3/4 x 3/4"	53	54	28	36	39	13
420148	1 1/2 x 1"	66	71	36	47	54	17
420149	1 1/2 x 1 1/4"	77	79	41	58	60	22
420150	2 x 1/2"	54	64	32	30	51	8
420151	2 x 3/4"	69	75	39	45	60	15
420152	2 x 1"	70	77	40	46	60	16
420153	2 x 1 1/4"	80	85	45	56	66	21
420366	2 x 1 1/2"	91	94	48	67	75	24

▶ F X F Union Cone Seats

256/340/U11

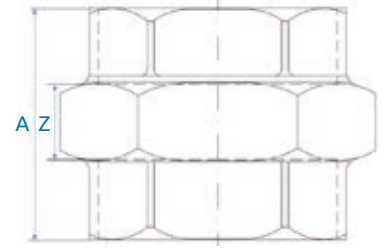

STOCK NO	Size (Inch)	DIM A (mm)	DIM Z (mm)
420160	1/2"	48	22
420161	3/4"	52	22
420162	1"	58	24
420163	1 1/4"	65	27
420164	1 1/2"	70	32
420165	2"	78	30
420166	2 1/2"	85	31
420167	3"	95	35
420168	4"	110	38

▶ M X F Union Cone Seats

257/341/U12

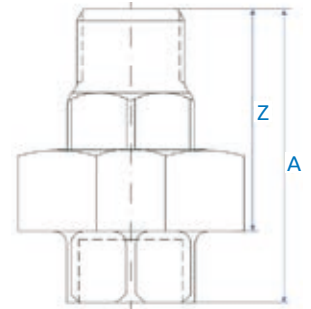

STOCK NO	Size (Inch)	DIM A (mm)	DIM Z (mm)
420175	1/2"	66	53
420176	3/4"	72	57
420177	1"	80	63
420178	1 1/4"	90	71
420179	1 1/2"	95	76
420180	2"	106	82
420181	2 1/2"	118	91
420182	3"	130	100

F X F 2BS Union Brass Seats

289/342A/U11



STOCK NO	Size (Inch)
404550	1/2"
404560	3/4"
404570	1"
404580	1 1/4"
404590	1 1/2"
404600	2" FxF

Plain Plugs

147/290/T8

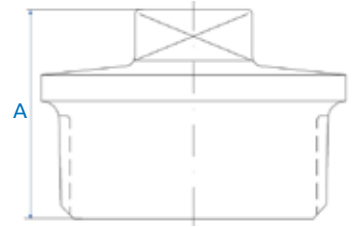

STOCK NO	Size (Inch)	DIM A (mm)
420183	1/2"	26
420184	3/4"	32
420185	1"	36
420186	1 1/4"	39
420187	1 1/2"	41
420188	2"	48
420189	2 1/2"	54
420190	3"	60

Heavy Barrel Nipples

BS EN 10241



STOCK NO	Size (Inch)	Size (mm)	DIM A (mm)
420198	1/2"	15	51
420199	3/4"	20	54
420200	1"	25	60
420201	1 1/4"	32	70
420202	1 1/2"	40	70
420203	2"	50	79
420204	2 1/2"	65	89
420205	3"	80	102

Close Taper Nipples

BS EN 10241

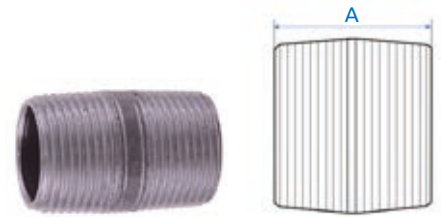

STOCK NO	Size (Inch)	Size (mm)	DIM A (mm)
420206	1/2"	15	37
420207	3/4"	20	39
420208	1"	25	46
420209	1 1/4"	32	51
420210	1 1/2"	40	51
420211	2"	50	60
420212	2 1/2"	65	69

Hex Nipples

144/280/N8

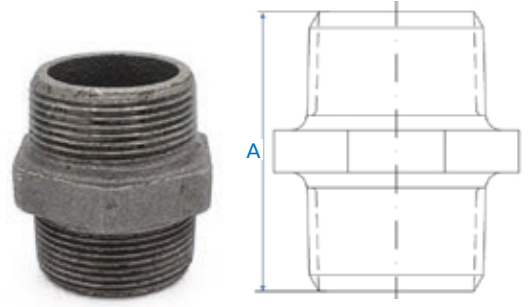

STOCK NO	Size (Inch)	DIM A (mm)
420213	1/2"	44
420214	3/4"	47
420215	1"	53
420216	1 1/4"	57
420217	1 1/2"	59
420218	2"	68
420219	2 1/2"	75
420220	3"	83

Hex Reducing Bushes

140/241/N4

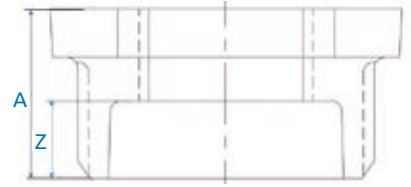

STOCK NO	Size (Inch)	DIM A (mm)	DIM Z (mm)
420223	1/2 x 3/8"	24	14
420225	3/4 x 3/8"	26	18
420226	3/4 x 1/2"	26	13
420228	1 x 3/8"	29	19
420229	1 x 1/2"	29	16
420230	1 x 3/4"	29	14
420232	1 1/4 x 1/2"	31	18
420233	1 1/4 x 3/4"	31	16
420234	1 1/4 x 1"	31	14
420236	1 1/2 x 1/2"	31	18
420237	1 1/2 x 3/4"	31	16
420238	1 1/2 x 1"	31	14
420239	1 1/2 x 1 1/4"	31	12
420240	2 x 1/2"	48	18
420241	2 x 3/4"	48	18
420242	2 x 1"	35	18
420243	2 x 1 1/4"	35	16
420244	2 x 1 1/2"	35	16
420246	2 1/2 x 1"	44	37
420247	2 1/2 x 1 1/4"	54	21
420248	2 1/2 x 1 1/2"	40	21
420249	2 1/2 x 2"	40	16
420250	3 x 1"	59	19
420251	3 x 2 1/2"	44	17
420252	4 x 3"	51	21

Caps
185/300/T1

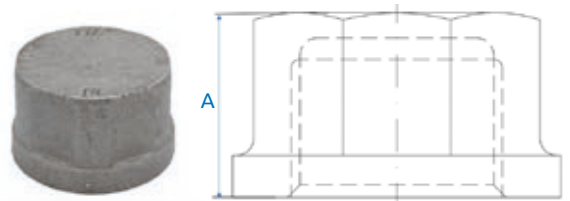

STOCK NO	Size (Inch)	DIM A (mm)
420191	1/2"	19
420192	3/4"	22
420193	1"	24
420194	1 1/4"	27
420195	1 1/2"	27
420196	2"	32
420197	2 1/2"	35

Back Nuts
150/310/P4

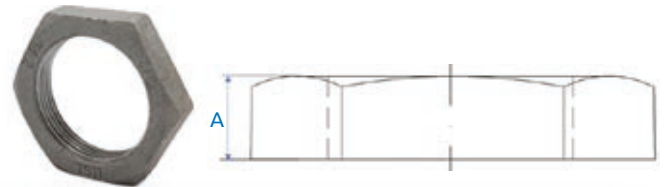

STOCK NO	Size (Inch)	DIM A (mm)
420253	1/2"	8
420254	3/4"	9
420255	1"	10
420256	1 1/4"	11
420257	1 1/2"	12
420258	2"	13
420259	2 1/2"	16

➤ Galvanised Fittings

▶ F X F 90° Short Bends

193/2A/D1

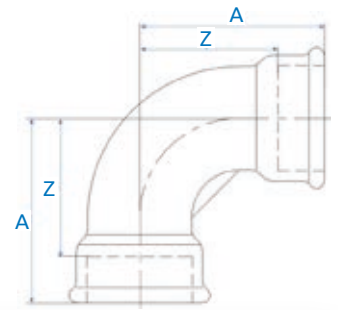

STOCK NO	Size (Inch)	DIM A (mm)	DIM Z (mm)
420267	1/2"	45	32
420268	3/4"	50	35
420269	1"	63	46
420270	1 1/4"	76	57
420271	1 1/2"	85	66
420272	2"	102	78
420273	3"	127	97

▶ F X F 90° Elbows

151/90/A1

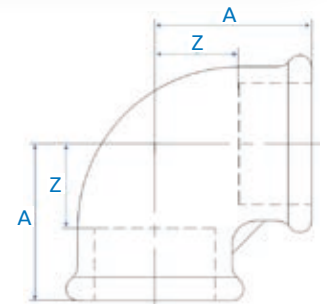

STOCK NO	Size (Inch)	DIM A (mm)	DIM Z (mm)
420274	1/2"	28	15
420275	3/4"	33	18
420276	1"	38	21
420277	1 1/4"	45	26
420278	1 1/2"	50	31
420279	2"	58	34

▶ F x F 45° Elbows

155/120/A1-45

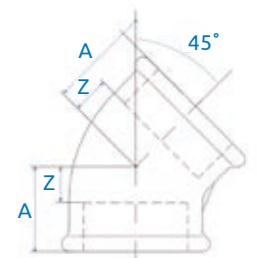

STOCK NO	Size (Inch)	DIM A (mm)	DIM Z (mm)
420280	1 1/2"	36	17
420281	2"	43	19
420282	3"	54	24

90° Tees

161/130/B1

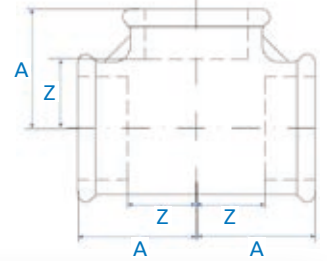

STOCK NO	Size (Inch)	DIM A (mm)	DIM Z (mm)
420283	1/2"	28	15
420284	3/4"	33	18
420285	1"	38	21
420286	1 1/4"	45	26
420287	1 1/2"	50	31
420288	2"	58	34

90° Reducing Tees

161/130/B1

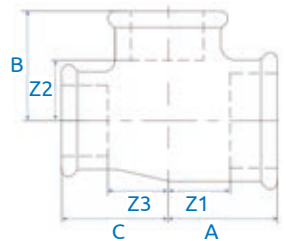

STOCK NO	Size (Inch)	DIM A (mm)	DIM B (mm)	DIM C (mm)	DIM Z1 (mm)	DIM Z2 (mm)	DIM Z3 (mm)
420289	1 x 1/2"	32	34	32	15	21	15
420290	2 x 1/2"	38	48	38	14	35	14
420291	2 x 3/4"	40	50	40	16	35	16

Hex Bushes

140/241/N4

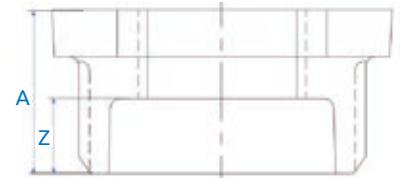

STOCK NO	Size (Inch)	DIM A (mm)	DIM Z (mm)
420299	1/2 x 3/8"	24	14
420300	3/4 x 1/2"	26	13
420301	1 x 1/2"	29	16
420302	1 x 3/4"	29	14
420303	1 1/4 x 1"	31	14
420304	1 1/2 x 1/2"	31	18
420305	1 1/2 x 1"	31	14
420306	1 1/2 x 1 1/4"	31	12
420307	2 x 1/2"	48	18
420308	2 x 3/4"	48	18
420309	2 x 1"	35	18
420310	2 x 1 1/4"	35	16
420311	2 x 1 1/2"	35	16
420312	2 1/2 x 2"	40	16

Equal Sockets

177/270/M2

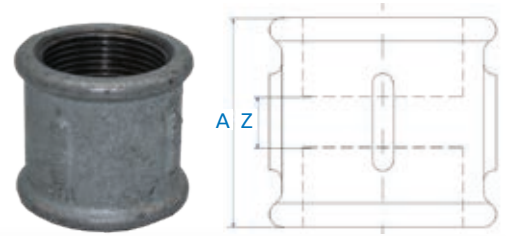

STOCK NO	Size (Inch)	DIM A (mm)	DIM B (mm)
420261	1/2"	36	10
420262	3/4"	39	9
420263	1"	45	11
420264	1 1/4"	50	12
420265	1 1/2"	55	17
420266	2"	65	17

Hex Nipples

144/280/N8

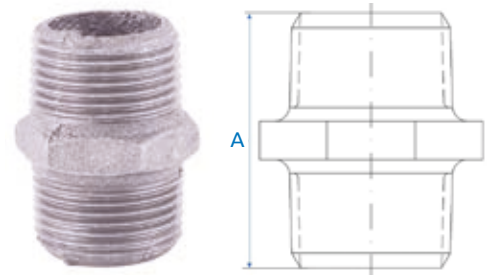

STOCK NO	Size (Inch)	DIM A (mm)
420320	1/2"	44
420321	3/4"	47
420322	1"	53
420323	1 1/4"	57
420324	1 1/2"	59
420325	2"	68

Plain Plugs

147/290/T8

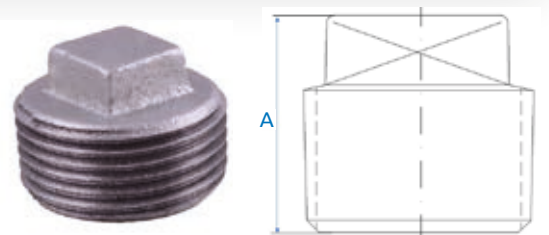

STOCK NO	Size (Inch)	DIM A (mm)
420292	1/2"	18
420293	3/4"	20
420294	1"	23
420295	1 1/4"	29
420296	1 1/2"	30
420297	2"	36

▶ Heavy Barrel Nipple

BS EN 10241



STOCK NO	Size (Inch)	Size (mm)	DIM A (mm)
420313	1/2"	15	51
420314	3/4"	20	54
420315	1	25	60
420316	1 1/4"	32	70
420317	1 1/2"	40	70
420318	2"	50	79
420319	2 1/2"	65	89

▶ F x F Union Cone Seats

256/240/U11

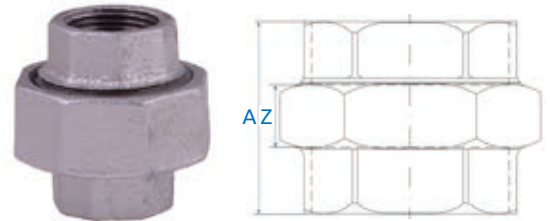

STOCK NO	Size (Inch)	DIM A (mm)	DIM Z (mm)
420326	1/2"	48	22
420327	3/4"	52	22
420328	1"	58	24
420329	1 1/4"	65	27
420330	1 1/2"	70	32
420331	2"	78	30

Brymec Technical Support

We recognise the importance of having top quality support from the manufacturer throughout every phase of the construction process, so we are here to provide assurance, technical support and assistance to safeguard your project.

Our Technical Team can assist you from Pre-construction right through to Post Contract and make sure that our attention to detail will be an asset for you.

Key Areas of Support

Specification

To ensure that our products suit the application in the best possible way we can offer advice or assistance at this stage

Project Support

This includes our excellent installation training, site attendance visits, verification and testing when required. Our Technical Laboratory provides quick results from all testing and analysis.

Post Contract

We can assist with full details for O & M Building Manuals, project information and records.

In-House Laboratory/Testing Facility

We have a purpose build laboratory to test our products to ensure they are of the utmost quality for your projects.



Warranty On Brymec Malleable Fittings and Threaded Steel Tube

At Brymec we place a huge emphasis on the quality and design of our range of manufactured products. We carry out extensive research, evaluation and design and then integrate Quality Checks at all stages of our processes.

Our Malleable Iron range has been carefully designed and selected to meet the highest quality standards. Products undergo stringent testing in compliance with our ISO 9001:2015 Quality Management System.

Due to the proven quality and reliability of the products, when using the Brymec Malleable Iron Fittings and Threaded Steel Tube, Brymec provide a market-leading warranty up to a maximum of 3 years from the date of delivery.

To qualify for this warranty all items must be installed correctly, for the correct application, in conjunction with correct adjacent materials and in the correct environment, within stated limits of use and performance as stated in our product information, data and any installation, operation and maintenance instructions which can be requested from us and on our website.

To view the full warranty terms and conditions visit [brymec.com/warranty](https://www.brymec.com/warranty)



Terms of Business

1. BACKGROUND

1.1 These Terms apply to the Contract between Brymec and the Customer for the sale of Brymec Products. Any other terms, whether implied by custom or practice, or which the Customer may seek to include, are specifically excluded.

1.2 Capitalised words (such as 'Contract'), have a specific meaning which is set out in 10 below.

2. CONTRACT TO BUY PRODUCTS

2.1 The Products are described on Brymec's website and in its catalogue. Specifications for Products are subject to change, in which case, Brymec will endeavour to supply an equivalent or suitable alternative.

2.2 When the Customer wishes to place an order for Products, it will provide a purchase order to Brymec. If Brymec accepts such order, it will issue an Order Acceptance to the Customer, at which point the Contract shall come into existence.

2.3 The Customer is responsible for ensuring that the details in the Order Acceptance are complete and accurate.

3. DELIVERY

3.1 Each delivery of the Products will be accompanied by a delivery note that shows the date of the Order Acceptance, the relevant Brymec reference number, and the type and quantity of the Products.

3.2 Brymec shall deliver the Products to the Delivery Location at any time after Brymec notifies the Customer that the Products are ready.

3.3 Delivery is completed on the completion of unloading of the Products at the Delivery Location (and, if applicable, Signed For.)

3.4 Customer must notify any issues of non-delivery, discrepancy or damage to Brymec within 2 business days of Delivery (see further 4.2 below).

3.5 Any dates quoted for delivery are approximate only, and the time of delivery is not of the essence. Brymec shall use all reasonable commercial efforts to meet any specific delivery dates. However, Brymec will not be liable for any delay in delivery of the Products.

3.6 If Brymec fails or is unable to deliver the Products for any reason (except for an Unforeseen Event), its liability shall be limited to the costs and expenses incurred by the Customer in obtaining replacement Products of similar description and quality in the cheapest market available, less the price of the Products. Brymec shall have no liability for any failure to deliver the Products to the extent that such failure is caused by an Unforeseen Event, or the Customer's failure to provide Brymec

with adequate delivery instructions or any other instructions that are relevant to the supply of the Products.

3.7 Brymec may deliver the Products by instalments, which shall be invoiced and paid for separately. Any delay in delivery or defect in an instalment shall not entitle the Customer to cancel any other instalment.

4. QUALITY

4.1 Brymec warrants that, on delivery, the Products shall conform in all material respects with their description and any applicable Specification. For products sold by weight, or in the manufacturer's packaging, Brymec may supply quantities of up to 5% more or less than the amount ordered.

4.2 Subject to 4.3 and 4.4 below, if i) the Customer gives notice in writing to Brymec within 2 business days of delivery that the Products do not comply with the Specification, and ii) Brymec is given a reasonable opportunity to examine such Products, and iii) the Customer returns such Products to Brymec's place of business at the Customer's cost, Brymec shall, at its option, replace the defective Products or refund the price of the defective Products in full.

4.3 Brymec shall not be liable for the Products' failure to comply with the warranty set out in clause 4.1 if: i) the Customer makes any further use of such Products after giving notice under 4.2 above; ii) the defect arises because the Customer failed to follow good trade practice or instructions as to the storage, commissioning, installation or use of the Products; or iii) the Customer alters or attempts to repair such Products.

4.4 Brymec may accept Product returned to it no later than 10 business days after the date of Delivery for credit or exchange, provided that the correct delivery details are provided. In this case, Brymec may make a charge for handling and restocking equal to 25% of the price of the returned Products.

4.5 Non-stock Products purchased by Brymec at the Customer's request are non-returnable and non-refundable.

4.6 Other than as set out above, Brymec shall have no liability to the Customer in respect of the Products' failure to comply with the warranty set out in clause 4.1.

5. TITLE AND RISK

5.1 The risk in the Products shall pass to the Customer on completion of delivery.

5.2 Title to the Products shall not pass to the Customer until the earlier of: i) Brymec receives payment in full for the Products; and ii) the Customer resells the Products, in which case title to the Products shall pass to the Customer at the time specified in 5.4 below.

5.3 Until title to the Products has passed to the Customer, the Customer shall store the Products separately from all other products held by the Customer so that they remain readily identifiable as Brymec's property, maintain the Products in satisfactory condition, and keep them insured against all risks for their full price from the date of delivery.

5.4 The Customer may use or resell the Products before Brymec receives payment for the Products, in which case it does so as principal and not as Brymec's agent, and title to the Products shall pass from Brymec to the Customer immediately before the time at which such reuse or resale by the Customer occurs.

6. PRICE AND PAYMENT

6.1 The price of the Products shall be the price set out in the Order Acceptance issued by Brymec. Brymec may, by giving notice to the Customer at any time up to delivery, increase the price of the Products to reflect any increase in the cost of the Products that is due to i) any factor beyond Brymec's control (including foreign exchange fluctuations, increases in taxes and duties, and increases in labour, materials and other manufacturing costs), or ii) any request by the Customer to change the delivery date(s), quantities or types of Products ordered, or the Specification.

6.2 The price of the Products excludes amounts in respect of value added tax (VAT), which the Customer shall additionally be liable to pay.

6.3 Unless otherwise stated on the Order Acceptance, Brymec shall be responsible for the cost of insurance and transport of the Products to the Delivery Location.

6.4 Brymec may invoice the Customer for the Products on or at any time after the Products have been despatched.

6.5 Unless otherwise stated in the Order Acceptance, the Customer shall pay the invoice in full and in cleared funds by the end of the month following the month the invoice was dated to the bank account nominated by Brymec. Time for payment is of the essence.

6.6 The Customer must raise any invoice queries with Brymec by email to creditcontrol@brymec.com within 28 days of the invoice date. Brymec will endeavour to respond within 2 business days and to propose a resolution to the Customer within 3 working days. The Customer must communicate any non-acceptance of such resolution to Brymec within 3 business days, failing which the relevant invoice remains payable according to these Terms.

6.7 If the Customer fails to make any payment due to Brymec under the Contract by the due date for payment, then Brymec shall be entitled to charge interest on the overdue amount at the rate of 4.0% per annum above the base rate from time to

time of the Bank of England. Such interest shall accrue on a daily basis from the due date until actual payment of the overdue amount, whether before or after judgment. The Customer shall pay the interest together with the overdue amount.

6.8 The Customer shall pay all amounts due under the Contract in full without any set-off, counterclaim or deduction. Brymec may set off any amount owing to it by the Customer against any amount payable by Brymec to the Customer.

7. LIMITATION OF LIABILITY AND INSURANCE

7.1 Nothing in these Terms shall limit or exclude Brymec's liability for: (i) death or personal injury caused by its negligence; ii) fraud or fraudulent misrepresentation; iii) breach of the terms implied by section 12 of the Sale of Products Act 1979; or defective products under the Consumer Protection Act 1987.

7.2 Subject to 7.1 above, Brymec shall under no circumstances whatsoever be liable to the Customer, whether in contract, tort (including negligence), breach of statutory duty, or otherwise, for any loss of profit, or any indirect or consequential loss arising under or in connection with the Contract; and

7.3 Brymec has obtained insurance cover in respect of its own legal liability for individual claims not exceeding £1,000,000 per claim. Therefore Brymec's total liability to the Customer in respect of all other losses arising under or in connection with the Contract, whether in contract, tort (including negligence), breach of statutory duty, or otherwise, shall in no circumstances exceed £1,000,000, and the Customer is responsible for making its own arrangements for the insurance of any excess loss.

8. UNFORESEEN EVENTS

8.1 Neither party shall be in breach of this Contract nor liable for delay in performing, or failure to perform, any of its obligations under this Contract if such delay or failure results from an Unforeseen Event. If the period of delay or non-performance continues for three months, the party not affected may terminate this Contract by giving one month's written notice to the affected party.

9. GENERAL

9.1 Assignment. The Customer may not assign, transfer, mortgage, charge, subcontract or deal in any other manner with any or all of its rights or obligations under the Contract without Brymec's prior written consent.

9.2 Confidentiality. Each party undertakes that it shall not at any time during this agreement, and for a period of 5 years after termination of this agreement, disclose to any person any confidential information concerning the business, affairs, customers, clients or suppliers of the other party, except as permitted by this paragraph. Each party may disclose the other

Terms of Business

party's confidential information: (i) to its employees, officers, representatives or advisers who need to know such information for the purposes of carrying out its obligations under or in connection with the Contract; and (ii) as may be required by law. No party shall use any other party's confidential information for any purpose other than to exercise its rights and perform its obligations under or in connection with this agreement.

9.3 Entire agreement. This Contract constitutes the entire agreement between the parties and supersedes and extinguishes all previous agreements and understandings between them, whether written or oral, relating to its subject matter. Each party agrees that it shall have no remedies in respect of any statement, representation, assurance or warranty (whether made innocently or negligently) that is not set out in this agreement.

9.4 Variation. No variation of this Contract shall be effective unless it is in writing and signed by the parties (or their authorised representatives).

9.5 Third party rights. No one other than a party to this Contract shall have any right to enforce any of its terms.

9.6 Law and jurisdiction. The Contract, and any dispute or claim arising out of or in connection with it shall be governed by and construed in accordance with the law of England and Wales. Each party agrees that the courts of England and Wales shall have exclusive jurisdiction to settle any dispute or claim arising out of or in connection with this Contract.

10. DEFINITIONS:

10.1 Brymec: Brymec Limited, whose registered office is at Unit C, Redlands, Coulsdon, Surrey, CR5 2HT.

10.2 Terms: the terms set out in this document.

10.3 Contract: the contract between Brymec and the Customer for the sale and purchase of the Products in accordance with these Terms.

10.4 Customer: the business or person who purchases the Products from Brymec.

10.5 Delivery Location: the location for delivery of the Products set out in the Order Acceptance, or such other location as the parties may agree.

10.6 Order Acceptance: a form issued by Brymec in response to a Customer's order for Products, specifying Product details, quantities, prices and costs of transportation.

10.7 Products: the products (or any part of them) set out in the Order Acceptance.

10.8 Signed For: a Customer requirement stated in the Order Acceptance that a delivery of Product must be signed for at the Delivery Location.

10.9 Specification: any specification for the Products set out on Brymec's website or in its catalogue.

10.10 Unforeseen Event: an event or circumstance beyond a party's reasonable control.

Quality Policy

Brymec Ltd (the 'Organisation') aims to provide defect free products and services to its customer on time and within budget.

The Organisation operates a Quality Management System that has gained BS EN ISO 9001 : 2015 certification, including aspects specific to the stock holding and supply of mechanical, plumbing and air conditioning products and services.

This gives us a platform to guarantee a structured approach to our continuous improvement cycle, and ensure we continue to meet and exceed the following key goals:

- › Excellence of service to our customers, delivering on site, in full, on time; in the relentless pursuit of total customer satisfaction.
- › Offering quality products and systems. We work with worldwide manufacturing plants (in line with our social and ethical policy) to source the best products for the UK market. We ensure that the products are fit for purpose and comply with the relevant approvals and standards. We also research and develop innovative solutions which will add value to our customers, developers and end users
- › To motivate, engage and continuously develop our team by providing training, coaching, knowledge sharing and investment to ensure their absolute competence.
- › To continue to invest in technology, working to understand customers' needs and streamline their buying processes to maximise efficiencies via modern technology.

This quality policy is endorsed and regularly reviewed by our Senior Management Team, and its scope is communicated to all Brymec employees via our website and other appropriate methods.

Our vision is to become an essential and indispensable supplier to the Building Services Contractor by providing excellence of service, quality products and continually investing in technology.

In order to achieve our vision, we ensure Brymec is an organisation where people love to work, upholding our core values of excellence, courage and collaboration to actively engage our team in contributing towards providing the highest level of customer satisfaction.

Luke Reiner
Managing Director

➤ Ethical Global Procurement Policy

ETHICAL POLICY - SOURCING

At Brymec we recognise the importance of credibility, integrity and trustworthiness in our success as a business. We are committed to upholding high ethical standards in all our operations, everywhere in the world. We believe in the principles of honesty, fairness, and respect for individual and community freedoms. The ethics of our UK operations are demonstrated through responsible:

- Business processes
- Corporate governance
- Custom and practice
- Quality management
- Safe working practices
- Corporate social responsibility
- Facility management
- Equality and diversity
- Anti-bribery and corruption
- Employee care

The Ethical Trading Initiative Code forms the basis of this policy

Additionally, as we expand our network of suppliers to source products globally, it is increasingly necessary to ensure that the organisations that we undertake business with also meet our expectations of standards of supply.

As a minimum Brymec Ltd expects its supply partners to comply with all local laws and regulations and to respect internationally recognised human and labour rights as well as international initiatives for climate change.

In particular we require that suppliers ensure:

- Working hours and remuneration are reasonable and meet the required local wage and working time laws
- Working conditions are safe and hygienic
- No discrimination is practised
- Employment is freely chosen
- Children are not employed, and local minimum age rules are in place
- Freedom of Association and the right to collective bargaining are respected
- No improper advantage, including the payment of bribes.
- Packaging and waste are subject to recycling and safe disposal guidelines
- That all sourcing of materials and manufacturing processes are subject to sustainability and renewability rules

Brymec carry out initial assessments and, on agreeing terms of business, provide the criteria against which the company has been measured by way of regulating ongoing requirements.

Brymec then carry out periodic on-site audits to ensure that compliance is maintained.

Brymec will work with its suppliers to guide and advise them in maintaining and improving required levels of environmental standards.

The Brymec Sourcing Director has responsibility for this policy and will report to the management meetings on any issues arising.

A copy of the full Ethical trading initiative can be found at www.ethicaltrade.org.

Notes

A series of horizontal dashed lines for writing notes.

Brymec



CO₂e
Assessed
Organisation

brymec.com

2023-V1.0