

Flange Mount Fully Lugged Ductile Iron Butterfly Valve

CIV 02



Technical Data

- Lugged & tapped butterfly valve
- Lever operation
- Body: ductile iron
- Disc: CF8M
- Stem: SS410
- Seat: WRAS EPDM
- Size: DN65 - DN300 (2½" to 10")
- Nominal Pressure: PN 16
- Temp. Range: -10°C to 120°C
- WRAS Temp. Range: -10°C to 85°C
- Suitable For: Water and neutral liquids



Features and Benefits

- Lug pattern design, safety for high pressure application
- O-ring stem sealing, low torque operation
- Streamlined stainless steel disc, lower water head lost
- ISO top flange as standard, easy to suit actuators
- Bi-directional shut-off seat
- Eccentric pin on the stem, protects the structure of the stem, providing safety and strength
- Both gear operated and lever operated are available

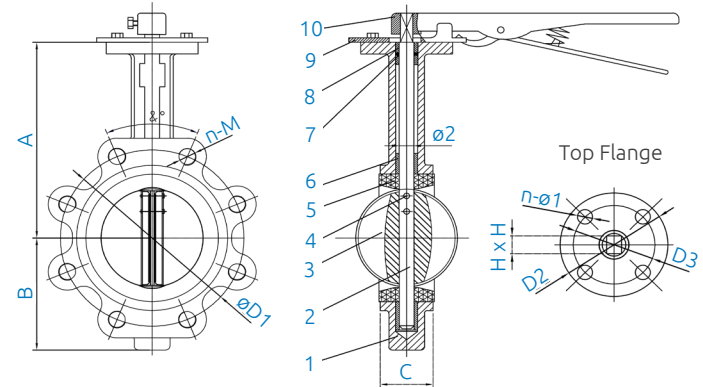

Applicable Standards

- Design standard: EN 593, BS 5155
- Connection standard: Suitable for EN1092-2
- Face to face standard: EN 558-1 BS 5155
- Top flange standard: ISO5211/1
- Testing standard: EN 12266-1

Material Specifications

NO	NAME	MATERIAL
1	Body	Ductile Iron JS1040
2	Disc	Stainless Steel CF8M
3	Stem	Stainless Steel SS410
4	Seat	EPDM
5	O-ring	EPDM

Dimensions

STOCK NO.	SIZE	A	B	C	D	$\phi 2$	ISO5211	K	E	$n-\phi$	HxH	L	OD	ID	WEIGHT (kg)	TORQUE
38942	DN50	140	80	43	52.9	12.6	F07	90	70	4 - 10	11 x 11	14	165	125	4.5	12
38943	DN65	150	89	46	64.5	12.6	F07	90	70	4 - 10	11 x 11	14	185	145	4.8	20
38944	DN80	158	95	46	78.8	12.6	F07	90	70	4 - 10	11 x 11	14	200	160	5.6	30
38945	DN100	176	114	52	104.0	15.8	F07	90	70	4 - 10	11 x 11	14	220	180	7.7	50
38946	DN125	190	127	56	123.3	18.9	F07	90	70	4 - 10	14 x 14	17	250	210	9.6	77
38947	DN150	212	139	56	155.6	18.9	F07	90	70	4 - 10	14 x 14	17	285	240	10.7	121
38948	DN200	235	174	60	202.5	22.1	F10	125	102	4 - 12	17 x 17	22	340	295	17.5	242
38949	DN250	265	203	68	250.5	28.5	F10	125	102	4 - 12	22 x 22	22	405	355	28.3	352
38841	DN300	305	242	78	301.6	31.6	F10	125	102	4 - 12	22 x 22	22	460	410	41.0	490