

Lockshield Bronze Gate Valve

GVA 02



Features and Benefits

- Screwed BSP Taper (ISO 7/1)
- Bronze Body and Disc
- Screwed Bonnet
- Lock shield

Pressure - Temperature Diagram

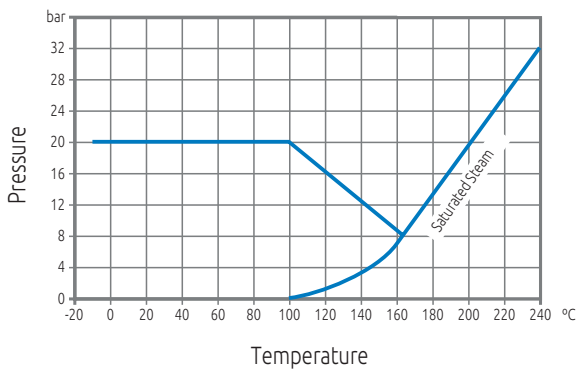

Dimensions

STOCK NO.	DN	L	H	S	WEIGHT (kg)
38863	15	47.5	70.0	6.3	0.3
38864	20	51.5	80.5	6.3	0.4
38865	25	58.6	94.0	6.3	0.6
38866	32	63.0	110.5	8.0	0.8
38867	40	66.5	123.5	8.0	1.1
38868	50	73.5	146.5	9.5	1.62

Technical Data

- Maximum working pressure: PN20
- Working temperature range: -10°C to +180°C

Applicable Standards

- PN20 Rated
- BS 5154 (BS EN 12288)
- WRAS Approved

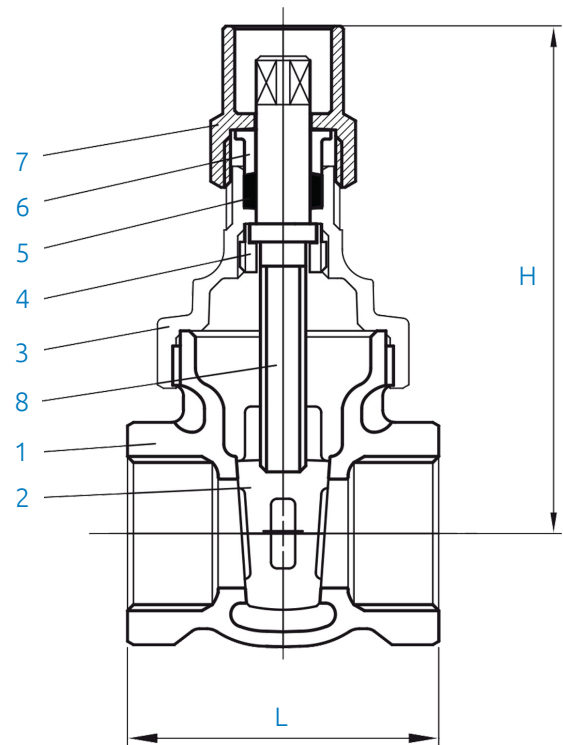

Material Specifications

NO	COMPONENT	MATERIAL
1	Body	Bronze
2	Disc	Bronze
3	Bonnet	Bronze
4	Lock nut	Brass
5	Stem packing	PTFE
6	Gland	Brass
7	Packing nut	Brass
8	Stem	Brass