

# DZR Brass Lever Ball Valve

## LBV 02



### Features and Benefits

- Compression ended
- DZR brass construction
- Full bore, bi-directional flow
- PTFE seats & seals
- WRAS approved
- Locking lever & spindle extension
- Options available

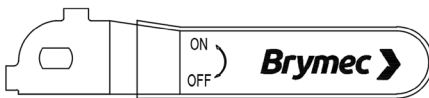
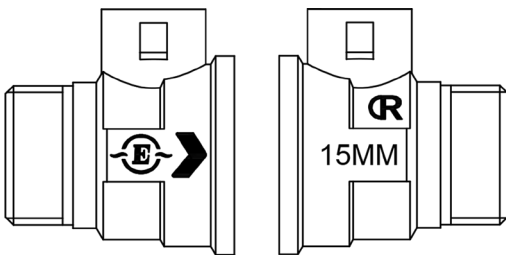

### Versions and Products Codes

STOCK NO	DN/A	B	C	D	E
38849	15	13	63.5	47.5	86
38850	22	19	80.0	51.5	86
38851	28	24	82.5	63.5	111.4
38852	35	32	110.5	74.3	138.5
38853	42	40	120.0	84	138.5
38854	54	49	136.5	90	169

### Technical Data

- Fields of applications: water
- Maximum working pressure: PN25
- Working temperature: -10°C to +110°C

### Applicable Standards

- Compression connections comply with BS EN 1254-2
- WRAS approved

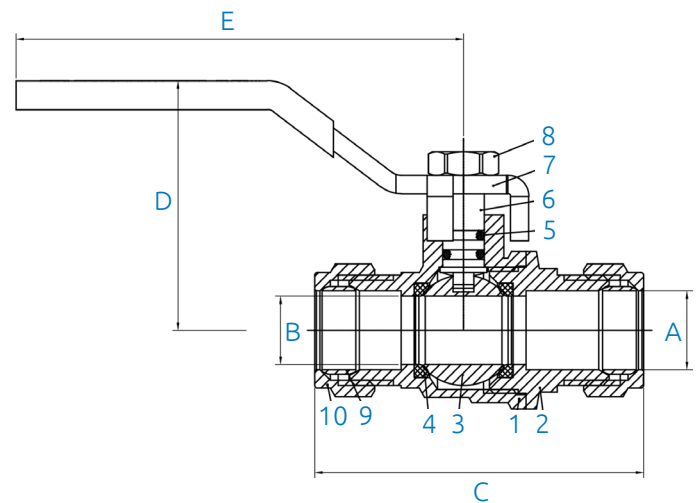

### Material Specifications

NO	NAME	MATERIAL	QUANTITY	OTHER
1	Body	CZ132	1	Natural
2	Bonnet	CZ132	1	Natural
3	Ball	Brass	1	Chrome Plated
4	Ball Seat	PTFE	2	WRAS Approved
5	O Ring	NBR	2	WRAS Approved
6	Stem	Brass	1	Natural
7	Nut	Q235	1	Nickel Plating
8	Handle	Q235+PVC	1	Red & Blue Chrome Plated
9	Comp Nut	Brass	2	Natural
10	Olive	T2	2	-

# Compression ¼ Turn Full Bore Lever Handle Brass Ball Valve - LBV 09



## Features and Benefits

- Compression connections
- PTFE seats & seals
- Full Bore, bi-directional flow
- Red & Blue handle included
- Locking lever and spindle extension options available

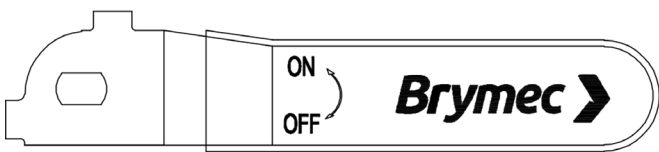
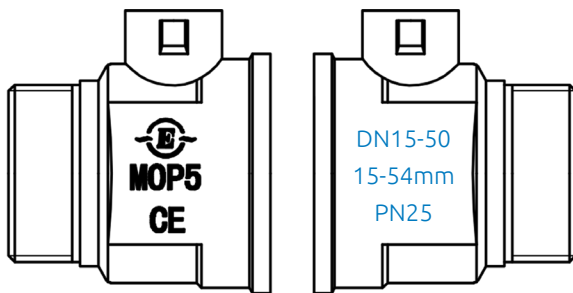

## Technical Data

- Fields of applications: water
- Maximum working pressure: 25 Bar
- Operating temperature range: -20°C to +110°C

## Applicable Standards

- Valves are manufactured in accordance with EN13828
- Compression connections comply with EN1254-2
- WRAS approved, full bore

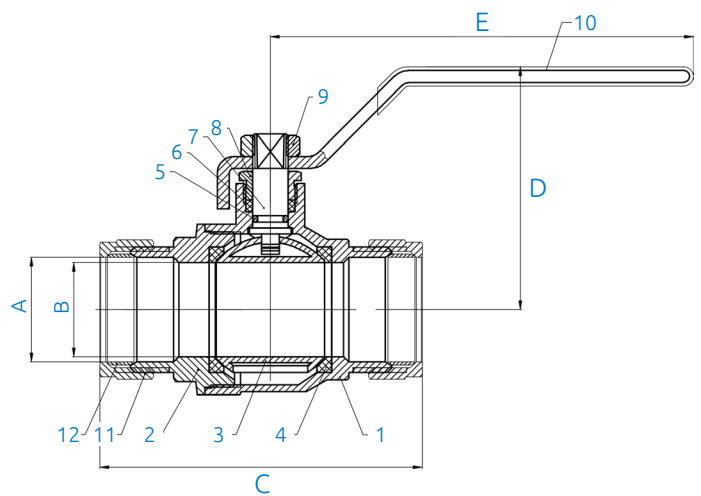

## Material Specifications

ITEM	PARTS	MATERIAL	QTY	OTHER
1	Body	HPb59-T	1	NP
2	Bonnet	HPb59-T	1	NP
3	Ball	HPb59-T	1	Chrome Plated
4	Ball Seat	PTFE	2	WRAS
5	O-ring	EPDM	1	WRAS
6	Packing	PTFE	1	WRAS
7	Stem	HPb59-T	1	NP
8	Lock nut	HPb59-T	1	NP
9	Nut	SS304	1	-
10	Handle	Q235+PVC	2	Red & Blue
11	Compression nut	HPb59-T	2	NP
12	Olive	H65	2	-

## Versions and Products Codes

STOCK NO	DN	SIZE	A	B	C	D	E
30750	½"	15	14.4	70.5	47	88	
30751	¾"	22	19	82	52	100	
30752	1"	28	24.5	91	65	125	
30753	1¼"	35	31.5	108	78	142	
30754	1½"	42	39.5	123	88	142	
30755	2"	54	49.5	144	96	165	

# ¼ Turn Compression Full Bore Brass Ball Valve

## LBV 10



### Features and Benefits

- Red & Blue butterfly T handle
- Full Bore, Bi-directional flow
- Compression connections for copper

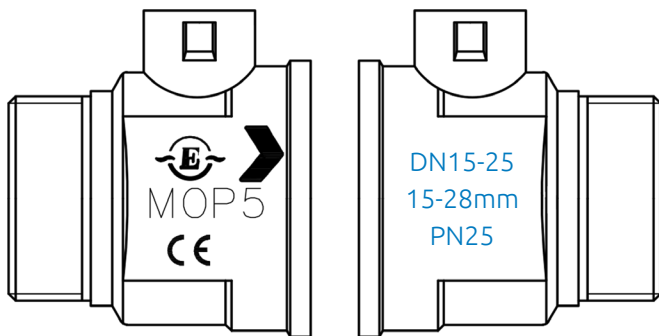

### Technical Data

- Fields of applications: water
- Maximum working pressure: 25 Bar
- Operating temperature range: -20°C to +110°C

### Applicable Standards

- Valves are manufactured in accordance with EN13828
- Compression connections comply with EN1254-2
- WRAS approved, full bore

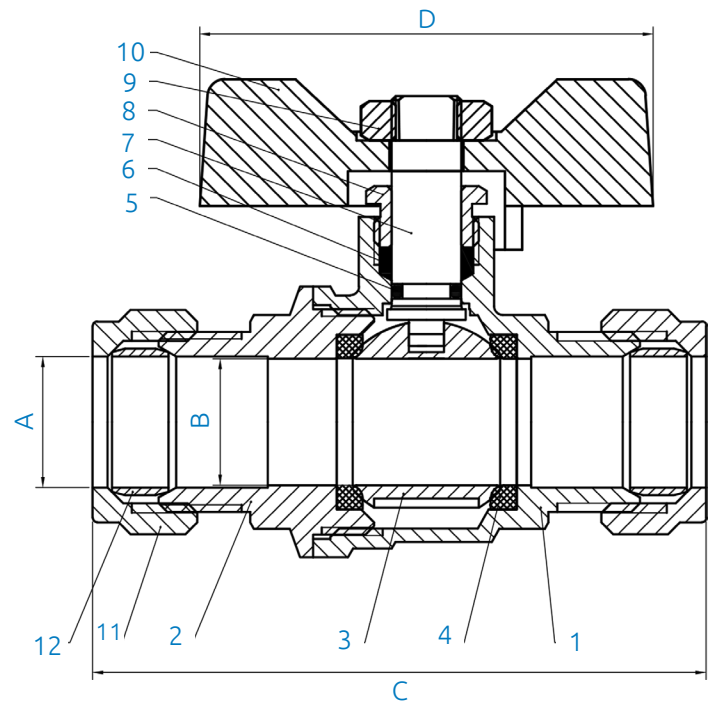

### Versions and Products Codes

STOCK NO	DN	A	B	C	D
30770	½"	15	14.5	70.5	52
30771	¾"	22	19	82	52
30772	1"	28	24.5	91	62

### Material Specifications

ITEM	PARTS	MATERIAL	QTY	OTHER
1	Body	ND15-25	1	NP
2	Bonnet	HPb59-T	1	NP
3	Ball	HPb59-T	1	Crome plated
4	Ball Seat	PTFE	2	WRAS
5	O-ring	EPDM	1	WRAS
6	Packing	PTFE	1	WRAS
7	Stem	HPb59-T	1	NP
8	Lock nut	HPb59-T	1	NP
9	Nut	SS304	1	-
10	Handle	Aluminium Alloy	2	Red & Blue
11	Compression nut	HPb59-T	2	NP
12		H65	2	-

# Press Fit DZR Brass Lever Ball Valve (M Profile)

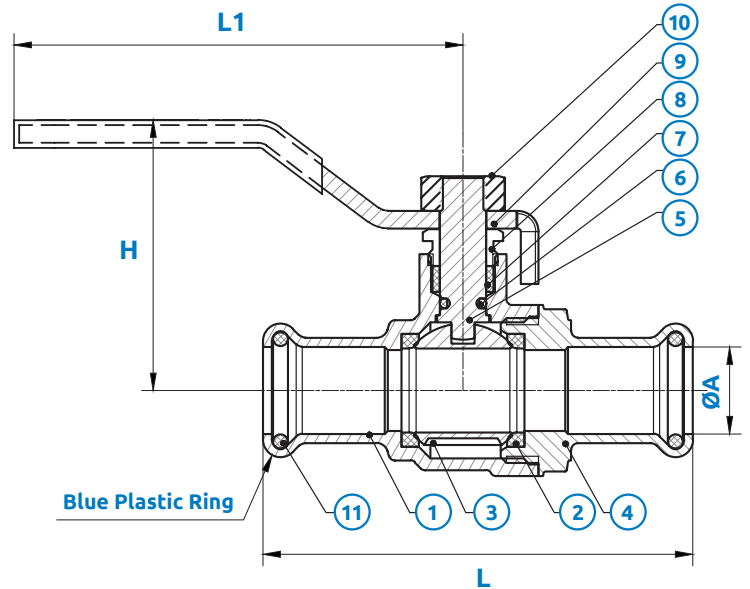

## Features and Benefits

- PTFE Seats and Seams
- EPDM 'O' Ring
- Red & Blue Levers Included
- Can be equipped with a Spindle Extension
- Can be equipped with a Locking Handle

## Applicable Standards

- WRAS Approved
- Press-Fit end comply with EN1254-7

## Technical Data

- Field of applications: Water
- Pressure Rating: PN16
- Working temperature: -10°C to +100°C
- Full Bore Design
- Press Profile: M Profile

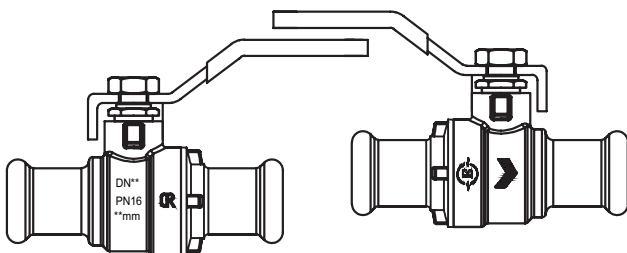

## Product Codes and Dimensions

STOCK NO	A (mm)	L (mm)	L1 (mm)	H (mm)
38806	15	74	92	47.5
38807	22	85.5	92	51.5
38808	28	99	115	63.5
38809	35	113.2	115	74.5
38810	42	135	180	84
38811	54	164.5	180	90

## Material Specifications

NO	NAME	MATERIAL	QTY	OTHER
1	Body	DZR brass / CW617N	1	Brass Colour / Nickel Plating
2	Ball Seat	PTFE	2	WRAS Approved
3	Ball	Brass / SUS304	1	Chrome Plated
4	Bonnet	DZR brass / CW617N	1	Brass Colour / Nickel Plating
5	Stem	Brass	1	
6	O-Ring	EPDM	2	WRAS Approved
7	Packing	PTFE	1	
8	Lock Nut	Brass	1	Brass Colour / Nickel Plating
9	Handle	Q235 + PVC / AL	2	
10	Nut	SS304	1	
11	O-Ring	EPDM	2	WRAS Approved

# F x F Threaded ¼ Turn Full Bore Brass DZR Ball Valve

## LBV 14



### Features and Benefits

- Screwed BSP Taper threads
- PTFE seats & seals
- Anti blow out stem
- Full bore, bi-directional flow
- Red & Blue handle included
- Locking lever & extension

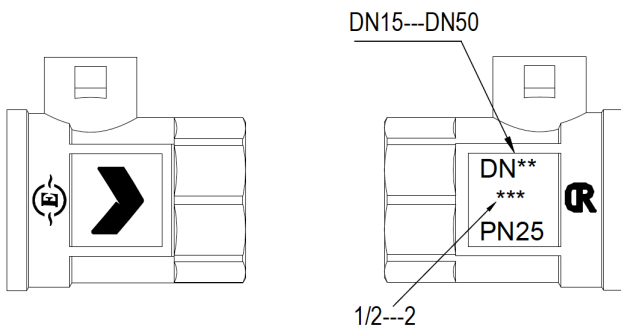

### Dimensions

STOCK NO.	A (DN)	B (mm)	C (mm)	D (mm)	E (mm)
38835	1/2"	14.5	55	50	93
38836	3/4"	19	67	53	93
38837	1"	24	75	62	115
38838	1 ¼"	30	75	72	127
38839	1 ½"	40	95	76	162
38840	2"	45	117	91	180

### Technical Data

- Fields of applications: water
- Maximum working pressure: PN25
- Working temperature: -20°C to +120°C
- Full bore

### Applicable Standards

- Valves are manufactured in accordance with: EN13828
- Female thread connections are to: ISO 7/1
- WRAS approved

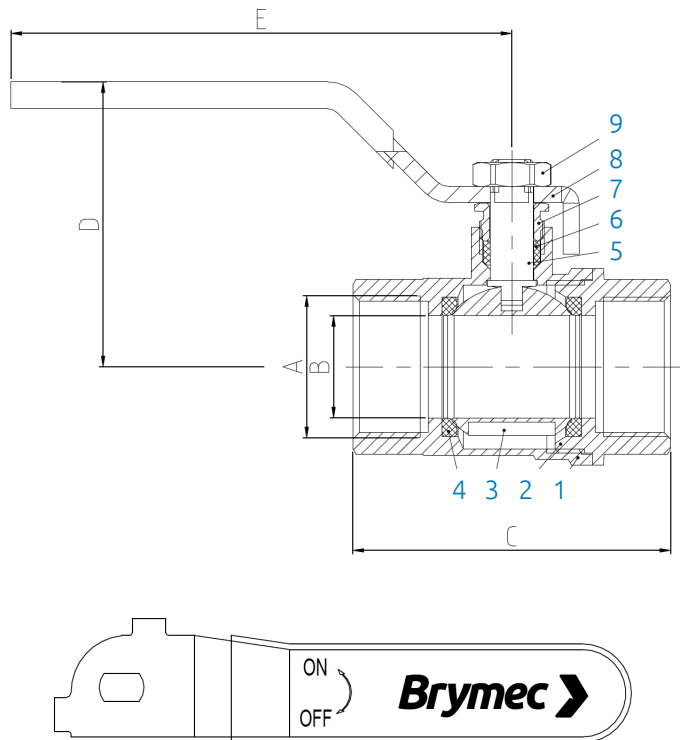

### Material Specifications

NO	COMPONENT	MATERIAL	QUANTITY	OTHER
1	Body	CW602N	1	Natural
2	Seat	CW602N	2	Natural
3	Ball	CW602N	1	Chrome Plated
4	Ball Seat	PTFE	1	-
5	Stem	Brass	1	Natural
6	Packing	PTFE	1	-
7	Lock Nut	Brass	1	Natural
8	Handle	Q235+PVC	1	Red & Blue
9	Nut	Q235	1	Zinc Plated

# F x F Threaded ¼ Turn Full Bore Brass Ball Valve

## LBV 05

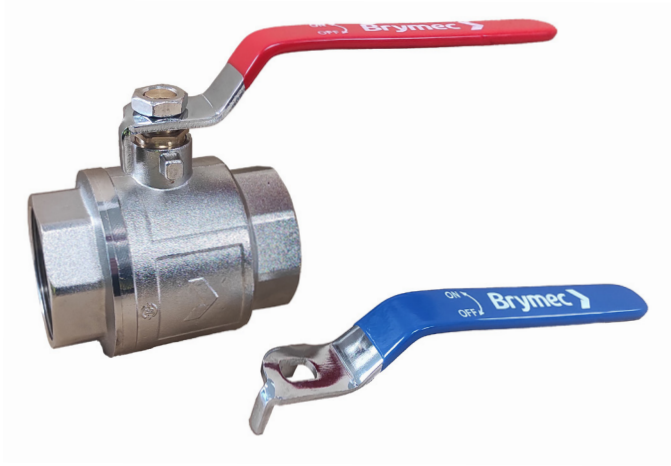

### Features and Benefits

- Screwed BSP parallel
- PTFE seats & seals
- Anti blow out stem
- Full bore, bi-directional flow
- Locking lever handles available
- Thermal extension spindle options

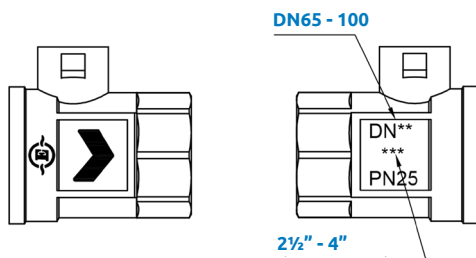

### Product Codes and Dimensions

STOCK NO	DN	A	B (mm)	C (mm)	D (mm)	E (mm)
30725	2 ½"	2 ½"	62	138	128.5	24.1
30726	3"	3"	73	168	132	225
30727	4"	4"	90	199	143	280

### Technical Data

- Fields of applications: Water
- Max. working pressure: PN25
- Operating temperature range: -20°C to +120°C

### Applicable Standards

- Valves are manufactured in accordance with: EN13828
- Female thread connections are to: ISO228
- WRAS approved, full bore

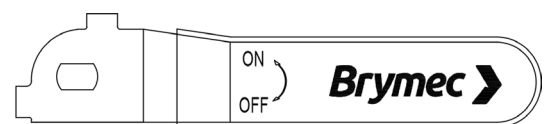
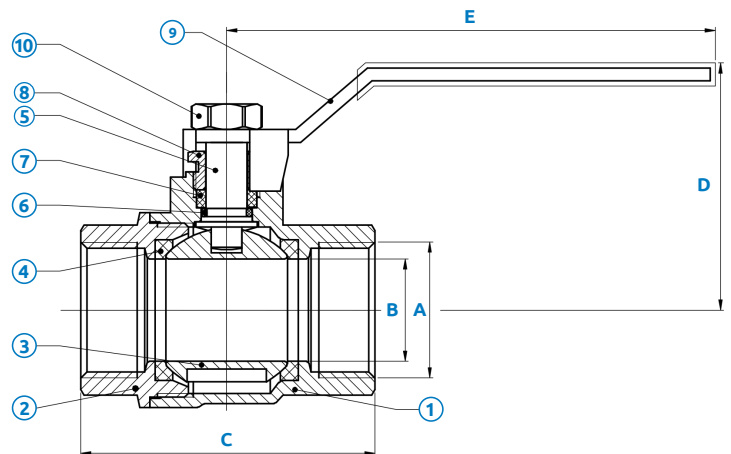

### Material Specifications

NO	NAME	MATERIAL	QTY	OTHER
1	Body	HPb59-T	1	Nickel Plating
2	Bonnet	HPb59-T	1	Nickel Plating
3	Ball	HPb59-T	1	Chrome Plated
4	Ball Seat	PTFE	2	-
5	O-Ring	HPb59-T	1	NP
6	Packing	EPDM	1	-
7	Stem	PTFE	1	-
8	Lock Nut	HPb59-T	1	Nickel Plating
9	Handle	Q235 + PVC	1	Red & Blue CP
10	Nut	Q235	1	Zinc Plating

# Lever Ball Valve Thermal Extension LBV 03

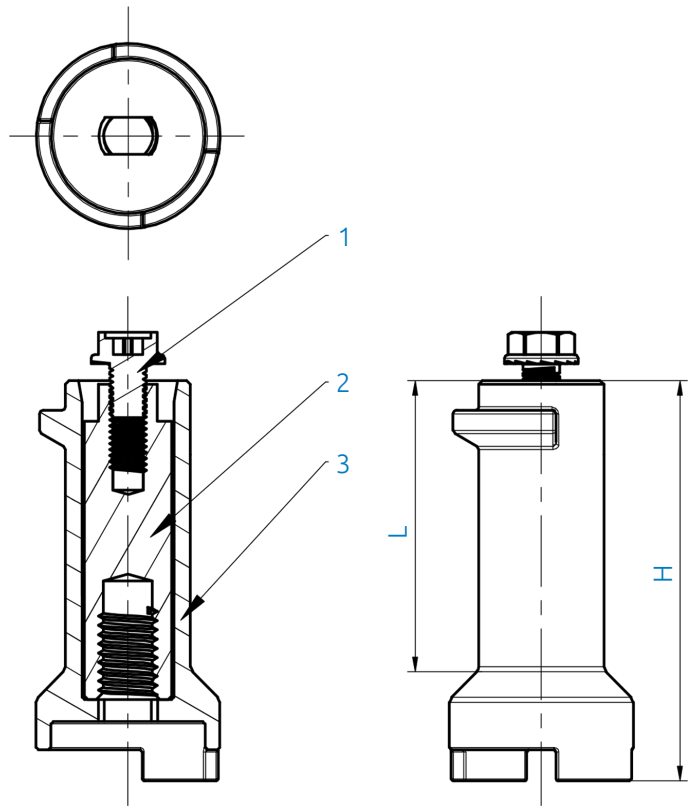
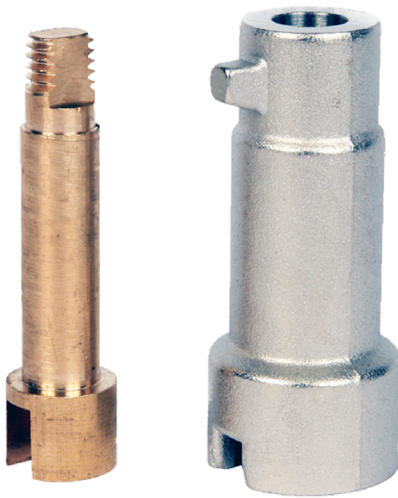

## Features and Benefits

- Lever operation post pipework insulation
- Can be retro fitted
- Suitable for both Brymec DZR and brass lever ball valves
- Robust bolted design

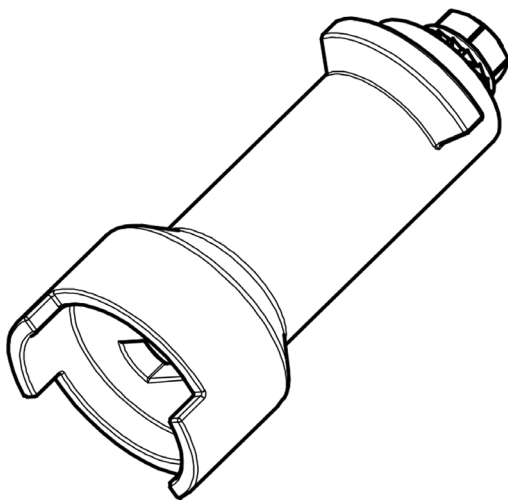

## Material Specifications

NO	NAME	MATERIAL	QUANTITY	OTHER
1	Screw	Brass	1	Nickel Plated
2	Stem	Brass	1	Surface Brass Colour
3	Sleeve	Q235	1	Nickel Plated

## Versions and Products Codes

STOCK NO	DN	H	L
36650	1/4" - 3/4" / 15 - 22mm	55	39
36651	1" / 28mm	57	40
36653	1 1/4" - 1 1/2" / 35 - 42mm	62	45
36654	2" / 54mm	66	48

# Lever Ball Valve Locking Lever Handle

## LBV 04

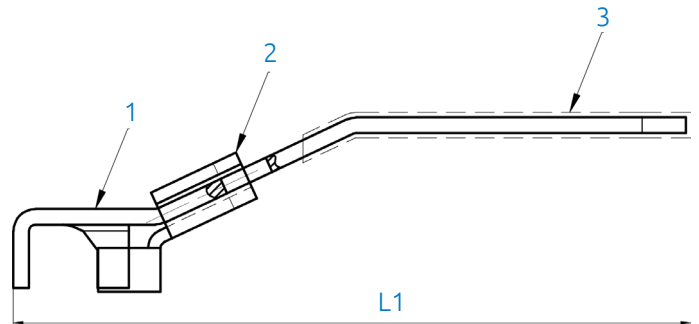

### Features and Benefits

- Prevents Unauthorised operation
- Can be retro fitted
- Suitable for both Brymec DZR and std brass lever ball valves

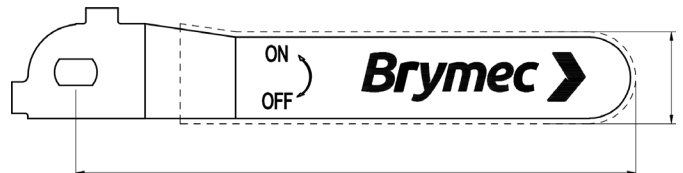

### Versions and Products Codes

STOCK NO	DN	W	L1	L2
36659	1/4" - 3/4" / 15 - 22mm	19	105	95
36660	1" / 28mm	21	145	130
36662	1 1/4" - 1 1/2" / 35 - 42mm	25	185	167
36663	2" / 54mm	28	198	178

### Material Specifications

NO	NAME	MATERIAL	QUANTITY	OTHER
1	Lever Handle	Q235	1	Chrome Plated
2	Slide Block	Q235	1	Chrome Plated
3	Sleeve	PVC	1	Black Colour



# ¼ Turn Full Bore Brass Ball Valve LBV 06



## Features and Benefits

- Red & Blue butterfly T handle
- Full Bore, Bi-directional flow
- F x F BSP threaded

DN8 / DN10 / DN15 / DN20 / DN25

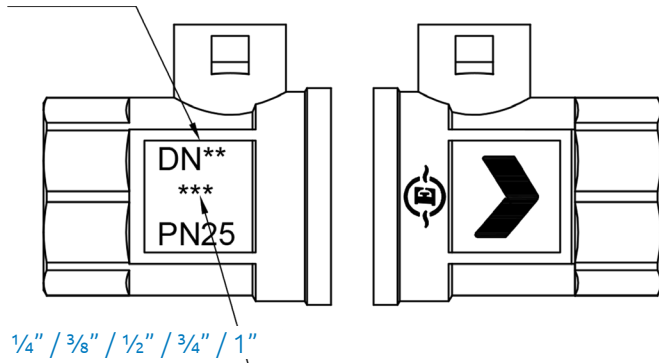

## Technical Data

- Fields of applications: water
- Maximum working pressure: 25 Bar
- Operating temperature range: -20°C to +120°C

## Applicable Standards

- Valves are manufactured in accordance with EN13828
- Female thread connections are to ISO228
- WRAS approved, full bore

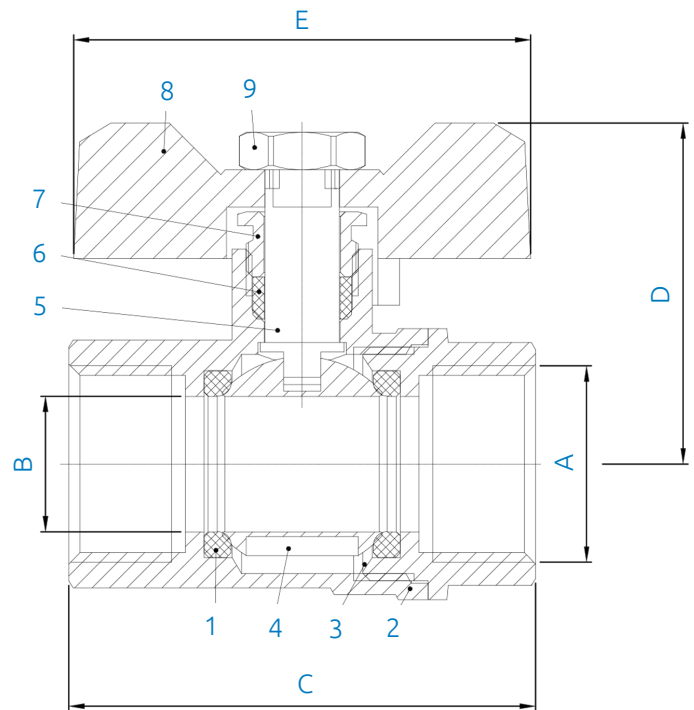

## Versions and Products Codes

STOCK NO	DN	SIZE	A	B	C	D	E
36667	8	G ¼	10	44	35.4	49	
36668	10	G ⅜	10	44	35.4	49	
30473	15	G ½	14.5	50	41	49	
30474	20	G ¾	19	59	41	49	
36669	25	G 1	24	65	53	65.5	

## Material Specifications

ITEM	PARTS	MATERIAL	QUANTITY	OTHER
1	Body	HPb59-T	1	NP
2	Bonnet	HPb59-T	1	NP
3	Ball	HPb59-T	1	Chrome Plated
4	Ball Seat	PTFE	2	WRAS
5	Stem	HPb59-T	1	NP
6	Packing	PTFE	1	WRAS
7	Lock Nut	HPb59-T	1	NP
8	Bfy Handle	Aluminium Alloy	2	Red & Blue
9	Nut	Q235	1	NP

# 1/4 Turn Full Bore Brass Ball Valve - Red & Blue Butterfly T Handle

## LBV 07



### Features and Benefits

- Red & Blue butterfly T handle
- Full Bore, Bi-directional flow
- F x M BSP threaded

DN8 / DN10 / DN15

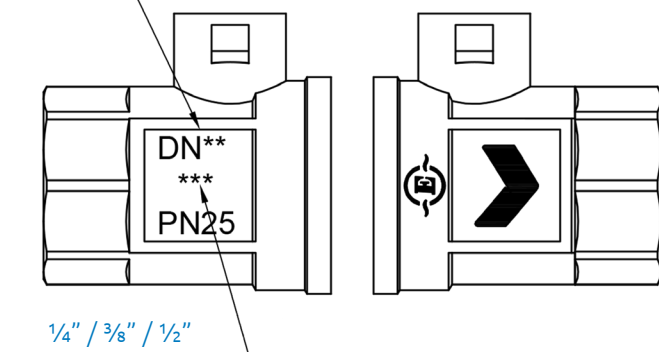

### Versions and Products Codes

STOCK NO	DN	SIZE A	B	C	D
36670	8	1/4	54	35.4	49
36671	10	3/8	54	35.4	49
36672	15	1/2	57	41	49

### Technical Data

- Fields of applications: water
- Maximum working pressure: 25 Bar
- Operating temperature range: -20°C to +120°C

### Applicable Standards

- Valves are manufactured in accordance with EN13828
- Female thread connections are to ISO228
- WRAS approved, full bore

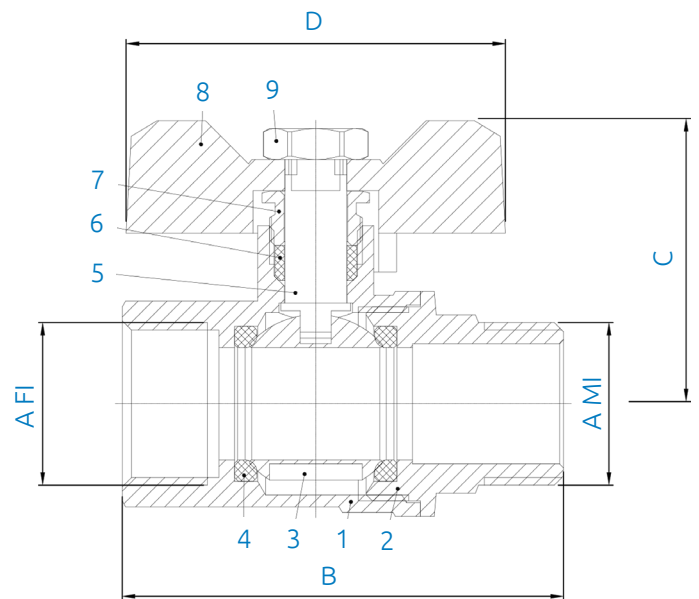

### Material Specifications

ITEM	PARTS	MATERIAL	QUANTITY	OTHER
1	Body	HPb59-T	1	NP
2	Bonnet	HPb59-T	1	NP
3	Ball	HPb59-T	1	Chrome Plated
4	Ball Seat	PTFE	2	WRAS
5	Stem	HPb59-T	1	NP
6	Packing	PTFE	1	WRAS
7	Lock Nut	HPb59-T	1	NP
8	Bfy Handle	Aluminium Alloy	2	Red & Blue
9	Nut	Q235	1	NP

# ¼ Turn Full Bore Brass Ball Valve - Red & Blue Butterfly T Handle

## LBV 08



### Features and Benefits

- Red & Blue butterfly T handle
- Full Bore, Bi-directional flow
- M x M BSP threaded

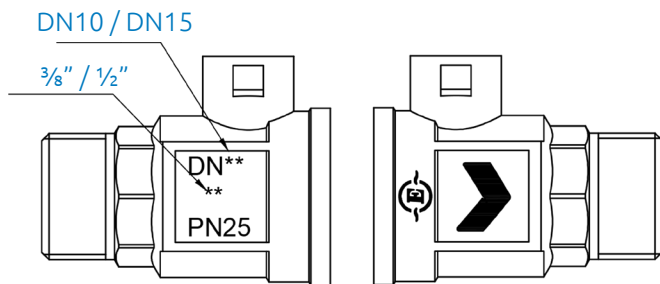

### Versions and Products Codes

STOCK NO	DN	SIZE	A	B	C	D	E
36676	10	¾"	10	61	35.5	49	
36677	15	½"	14.5	66	36.5	49	

### Technical Data

- Fields of applications: water
- Maximum working pressure: 25 Bar
- Operating temperature range: -20°C to +120°C

### Applicable Standards

- Valves are manufactured in accordance with EN13828
- Female thread connections are to ISO228
- WRAS approved, full bore

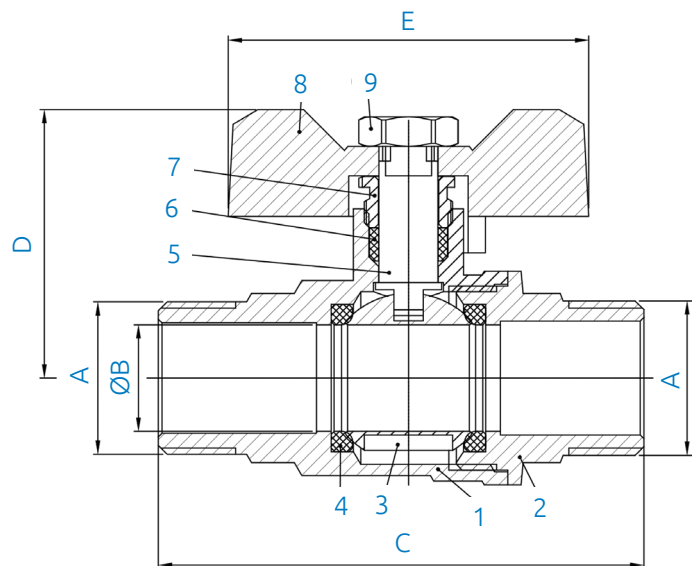

### Material Specifications

ITEM	PARTS	MATERIAL	QUANTITY	OTHER
1	Body	HPb59-T	1	NP
2	Bonnet	HPb59-T	1	NP
3	Ball	HPb59-T	1	Chrome Plated
4	Ball Seat	PTFE	2	WRAS
5	Stem	HPb59-T	1	NP
6	Packing	PTFE	1	WRAS
7	Lock Nut	HPb59-T	1	NP
8	Bfy Handle	Aluminium Alloy	2	Red & Blue
9	Nut	Q235	1	NP

# 1/4 Turn Gas Brass Ball Valve

## LBV 11



### Technical Data

- Temperature range: -20°C to +60°C
- Max working pressure at 20°C with liquid hydrocarbons: 1, 2 MPa (12 Bar)
- Max operating pressure (MOP) with gas: 0, 5 MPa (5 Bar)

### Applicable Standards

- DIN EN 331:2016 certified; class A
- EN 331:2015 approved
- CE approved
- Threads in accordance with EN 10226-1



### Features and Benefits

- Gas Ball valve with BSP female connections
- Yellow handle for use in gas installations
- Full bore Bi-directional flow
- EN 311 2016 certified Class A
- Suitable for dangerous gas and liquid hydrocarbons
- Stem with Double O-ring
- Nut with anti-corrosion coating with guarantee seal and hologram

### Materials Specification

NAME	MATERIAL	QUANTITY	OTHER
Body	CW617N	1	Chrome Plated
Seats	PTFE	2	Low friction profile
Ball	Brass	1	Chrome Plated
Body End	CW617N	1	Chrome Plated
Lever	Steel	1	PVC Yellow
Nut	Steel	1	Anti-Corrosion

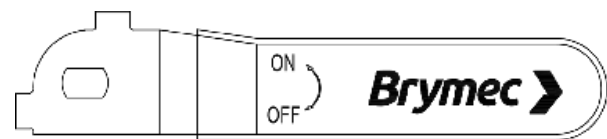
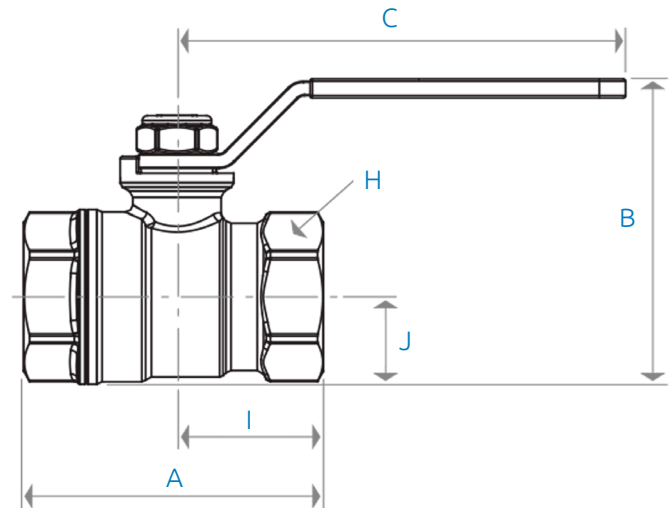

### Versions and Products Codes

STOCK NO	DN	SIZE Rp	A	I	B	J	C	H
30732	10	3/8"	45	22	46	14	77	21
30733	15	1/2"	54	27	49	15	77	25
30734	20	3/4"	63	31	64	18	94	32
30735	25	1"	75	38	73	23	94	39
30738	32	1 1/4"	84	42	82	28	94	48
30739	40	1 1/2"	93	46	100	33	136	55
30740	50	2"	107	54	115	41	136	67
30741	58	2 1/2"	146	73	154	52	173	82

# ¼ Turn Gas Brass Ball Valve

## LBV 12



### Features and Benefits

- Gas Ball valve with BSP female connections
- Yellow handle for use in gas installations
- Full bore Bi-directional flow
- WRAS & EN 331 approved
- Locking lever, tee handle & spindle extension options

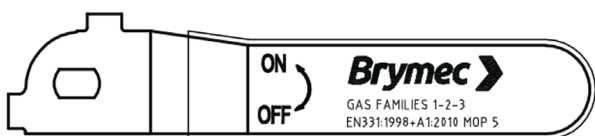
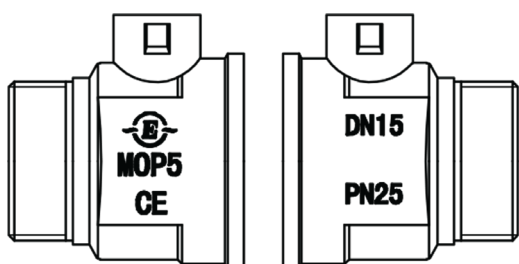

### Versions & Product Codes

STOCK NO.	DN	A	B	C	D	E
30758	15	15	14.5	70.5	47	88
30759	22	22	19	82	52	100
30760	28	28	24.5	91	65	125
30761	35	35	31.5	108	78	142
30762	42	42	39.5	123	88	142
30763	54	54	49.5	144	96	165

### Technical Data

- Fields of applications: gas and water
- Maximum working pressure: 25 Bar (water); -20°C to +60°C (gas)
- Operating temperature range: -20°C to +110°C (water); -20°C to +60°C (gas)

### Applicable Standards

- Valves are manufactured in accordance with EN331
- Compression connections comply with EN1254-2
- WRAS approved, full bore

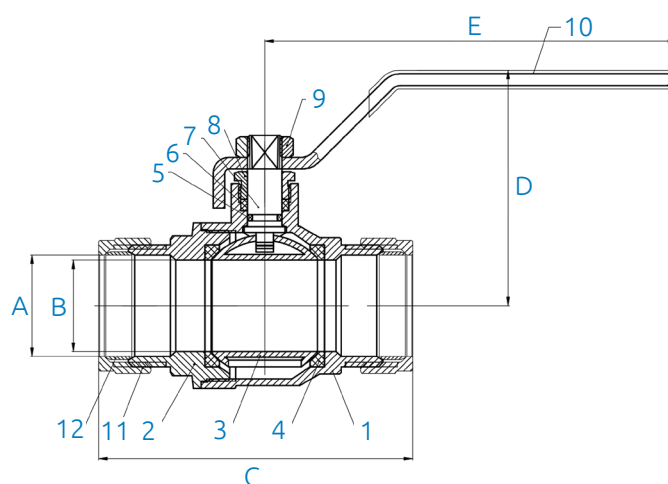

### Materials Specification

ITEM	NAME	MATERIAL	QTY	OTHER
1	Body	CW617N	1	NP
2	Bonnet	CW617N	1	NP
3	Ball	CW617N	1	Chrome Plated
4	Ball seat	PTFE	2	WRAS
5	O-ring	NBR	1	WRAS
6	Packing	PTFE	1	WRAS
7	Stem	Brass	1	NP
8	Lock nut	Brass	1	NP
9	Nut	SS304	1	-
10	Handle	Q235+PVC	1	Yellow
11	Compression nut	Brass	2	NP
12	Olive	H65	2	-

# M x M BSP Union Pressure Reducing Valve

## PRV 01



### Features and Benefits

- Specifically designed for hot and cold residential services
- Controls static & dynamic pressure
- Compensated seat ensures downstream pressure is independent of upstream pressure changes
- Hydraulic design ensures low pressure loss even with a large number of outlets open
- Equalises hot and cold water supplies
- Prevent excess pressure at water outlets to improve and reduce water use
- Internal cartridge mechanism is one assembly simplifying removal for cleaning
- Supplied with pressure gauge

### Versions and Products Codes

STOCK NO	A	B	C	D	E	Kg
36112	R 1/2"	112	20.5	54	140	0.92
36113	R 3/4"	112	20.5	54	160	1.06
36114	R 1"	112	20.5	54	180	1.38
36115	R 1 1/4"	178	40	73	200	2.6
36116	R 1 1/2"	178	40	73	220	3.4
36117	R 2"	178	40	73	250	4.3

### Technical Data

- Max inlet pressure: 16 bar
- Outlet pressure setting range: 1 to 6 bar
- Factory setting: 3 bar
- Max working temperature: 80°C
- Pressure gauge range: 0 to 10 bar
- Pressure gauge connection: G1/4
- Filter mesh size: 0.51mm
- Medium: potable water

### Applicable Standards

- Complies with EN 1567
- Screwed ends are BS EN 10226
- WRAS approved

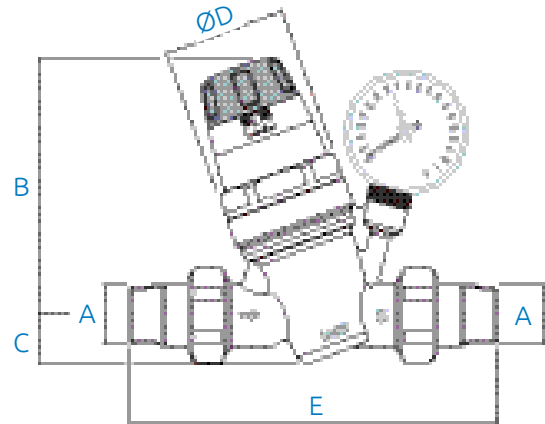

### Material Specifications

COMPONENT	MATERIAL	GRADE
Body	DZR copper alloy	BS EN 12165 CW602N
Cover	Nylon	PA 66GF30
Control stem	Stainless steel	AISI 304
Cartridge	POM	
Internal components	DZR copper alloy	BS EN 12164 CW602N
Diaphragm	Nitrile rubber	
Seals	Nitrile rubber	
Strainer screen	Stainless steel	AISI 304

# Compression Pressure Reducing Valve

## PRV 02



### Features and Benefits

- Specifically designed for hot and cold residential services
- Equalises hot and cold water supplies
- Prevents excess pressure at water outlets to improve and reduce water use
- 1 valve fits both 15 & 22mm compression connection
- Supplied with pressure gauge

### Versions and Products Codes

STOCK NO	A
30973	15 / 22mm

### Technical Data

- Suitable for: Water
- Maximum upstream pressure: 16 Bar
- Downstream pressure setting range: 1-6 Bar
- Maximum working temperature: 65°C
- Pressure gauge scale: 0-10 Bar
- Factory set pressure: 3 Bar

### Applicable Standards

- Complies with BS EN 1567
- Compression connections comply with EN1254-2
- WRAS approved

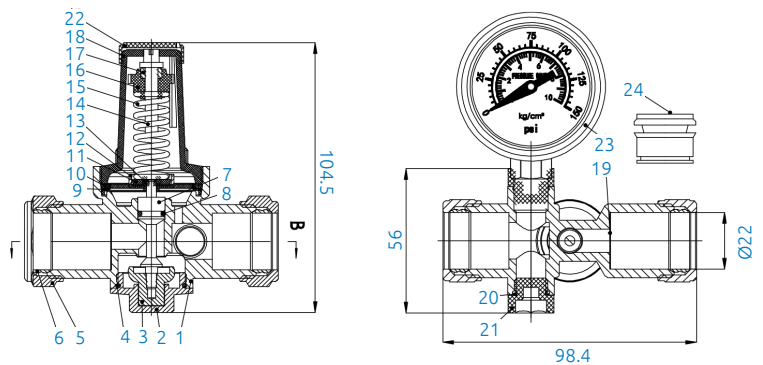

### Material Specifications

NO	PARTS NAME	QTY	MATERIAL
1	Body	1	CW602N
2	Bonnet	1	CW602N
3	Pressing cover	1	CW602N
4	O-ring	1	EPDM
5	Compression nut	1	HBb59-T
6	Olive	1	H62
7	Stem	1	CW602N
9	Clasp	1	SS304
12	Brass seat	1	CW602N
15	Spring	1	SS304
18	Plastic cap	1	PPO
19	Strainer	1	SS304
22	Protective case	1	PPO
23	Pressure gauge	1	Composite
24	Reducer	1	HPb59-T

# Water Meter Assembly with Carrier & Lagging (no Meter)

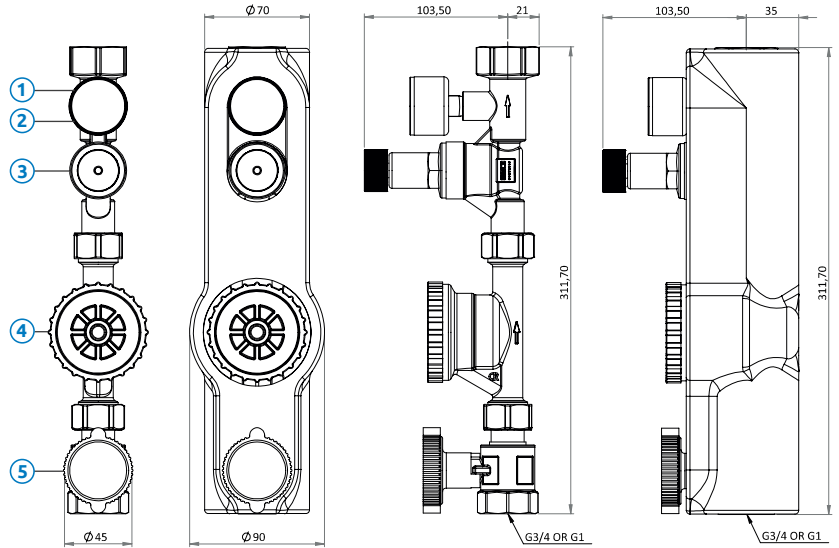

Number	Description
1	Pressure Gauge (0-16bar)
2	Double Check Valve (DCV)
3	Combined Pressure Reducing Valve (PRV) + Strainer
4	Water Meter Carrier + Dust Cap
5	Isolating Ball Valve

## Features and Benefits

- Compact and space saving (half the size of traditional branch valve assemblies)
- WRAS, KIWA Regulation 4 (KUKreg4) PRV conforms to BSEN 1567
- Easy to install, either horizontally or vertically
- Position of water meter can be adjusted to suit, making it easy to read the display
- Supplied pre-tested to save time on site
- Robust, with minimal service and maintenance requirements
- Supplied with carrier, ready to fit any approved water meter (or with 80-110mm spacer where required)
- Dust cap on water meter carrier protects from contamination during installation\*
- Supplied with insulation as standard, which provides protection and reduces heat loss and risk of condensation

\* Please note this provides temporary protection only and must be removed and replaced with a meter before commissioning.

## Product Codes

Stock no	Size
30967	3/4" Water Meter Assembly with Carrier & Lagging (No Meter)
30968	1" Water Meter Assembly with Carrier & Lagging (No Meter)
30946	3/4" Water Meter Carrier MxM c/w 1 1/2" blanking cap & seal

## Technical Data

- Medium: DCW / Potable water
- Min. working pressure: 1 bar
- Max. working pressure: PN16
- Outlet adjustable pressure: 1.5 - 6 bar
- Pre-set outlet pressure: 4 bar
- Optimum PRV reduction ratio: 2:1
- Maximum pressure reduction ratio: 3:1
- Recommended velocity range for avoidance of noise: 1-2 m/s
- Working temperature range: 5 - 85°C
- Strainer size: 350 Micron
- Connections: 3/4" BSP or 1" BSP
- Water meter carrier connection: DN40 internal thread (screwed)

## Material Specifications

Name	Material	Grade
Body	Brass	CW602N
Strainer mesh	Stainless Steel	AISI304
O-rings + flat seals	Rubber	EPDM
Ball valve	Brass	CW617N
Ball valve seal	Plastic	PTFE
Ball valve stem	Brass	CW614N
Ball valve handle	Plastic	Nylon 60% glass fibre
Insulation Shell	Plastic	PE
Water Carrier Cap	Plastic	Technyl A
Water Meter Spacer	Plastic	Radilon A



## Technical Specification

Description	Units	With Carrier		With 110mm Spacer		
		Exc. Insulation	Inc. Insulation	Exc. Insulation	Inc. Insulation	
<b>General</b>						
Height	mm	312				
Width	mm	Ø67	Ø90	45	Ø90	
Depth	mm	104				
Total Weight	Kg	3/4"	1.02	1.06	1.57	1.61
		1"	0.92	0.96	1.47	1.51
Suitable Media	Potable water					
Standards & Approvals	WRAS, KIWA Regulation 4 (KUKreg4) PRV conforms to BSEN 1567					
Mounting Position	Horizontal or vertical					
Operating temperature range	°C	5 - 85				
Max. operating temperature medium according to EN 1567	°C	30				
Operating inlet pressure range	bar	1 - 16				
Outlet adjustable pressure range	bar	1.5 - 6				
Factory pre-set outlet pressure	bar	4				
Internal insulation layer (10mm PE 3013)	Thermal conductivity of internal insulation layer at 10°	W/mK	0.0320			
	Thermal conductivity of internal insulation layer at 40°	W/mK	0.0404			
Density of internal insulation shell	Kg/m <sup>3</sup>	30				
Density of external insulation shell	Kg/m <sup>3</sup>	80				
Fire resistance of insulation (where ordered) to DIN 75200	mm/min	<100				
<b>Transportation &amp; storage requirements</b>						
Ambient temperature range permissible	°C	5 - 55				
Ambient relative humidity range permissible	°C	25 - 85 (non-condensing)				

# DZR Brass Venturi Commissioning Valve Set

## COM 04



### Features and Benefits

- Drain connection 1/4" F - ISO 228
- Sensor holder for needle Ø3mm and length 30-40mm
- Closing function
- Presetting possibility
- Venturi flowmeter for flow rate measurement by means of pressure probes

### Dimensions

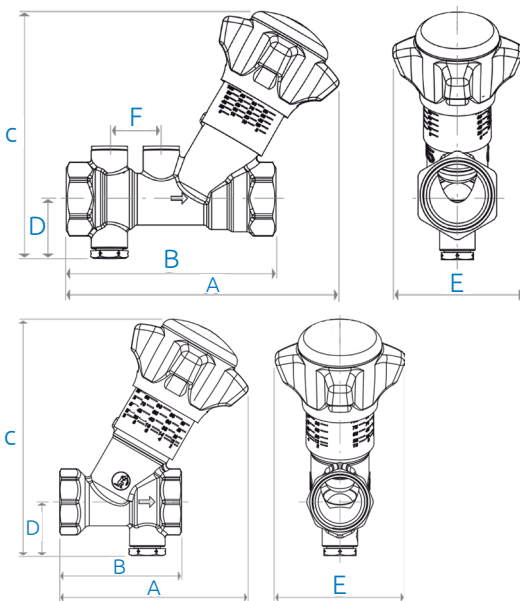

### Technical Data

- Temp. Range: 5°C to 110 °C
- Max. Working Pressure: 25 bar (2500 kPa)

### Components & Materials Specification

- Handwheel: ABS, white colour
- Body: dezincification resistant brass DZR (EN 12165 - CW602N)

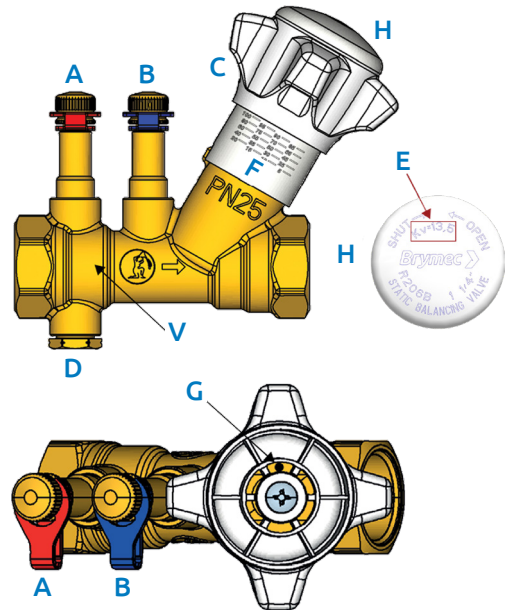

ITEM	DESCRIPTION
A	High pressure probe
B	Low pressure probe
C	Handwheel
D	Drain 1/4" F
E	Kv of the Venturi flow meter
F	Scale for 0 -100% setting (20 positions)
G	Presetting screw (limiting the stroke)
H	Removable head (for presetting) with imprinted the Venturi Kv
V	Venturi flow meter

STOCK NO.	CONNECTIONS	A (mm)	B (mm)	C (mm)	D (mm)	E (mm)	F (mm)	Kv	Kv Venturi
38897	1/2 LF	93	54	117	24	64	-	2.1	*
38891	1/2"	131	95	119	25	64	25	2.7	4.0
38892	3/4"	131	101	118	28	64	25	5.5	7.5
38893	1"	131	110	122	32	64	25	7.0	11.0
38894	1 1/4"	137	120	129	35	64	25	9.5	13.5
38895	1 1/2"	163	140	166	39	64	25	18.8	24
38896	2"	169	154	172	45	70	25	25.5	31

\* 1/2" LF close coupled to fixed orifice plate. Request metering station datasheet for details

# DZR Brass Double Regulating Valve COM 03



## Features and Benefits

- Drain connection 1/4" F - ISO 228
- Closing function
- Presetting possibility

## Technical Data

- Temp. Range: 5 - 110 °C
- Max. Working Pressure: 25 bar

## Product Specifications

- BSP Parallel ISO 228/1 Connections
- Static balancing via Venturi principle

## Components & Materials Specification

- Handwheel: ABS, white color
- Body: dezincification resistant brass DZR (EN 12165 - CW602N)

## Dimensions

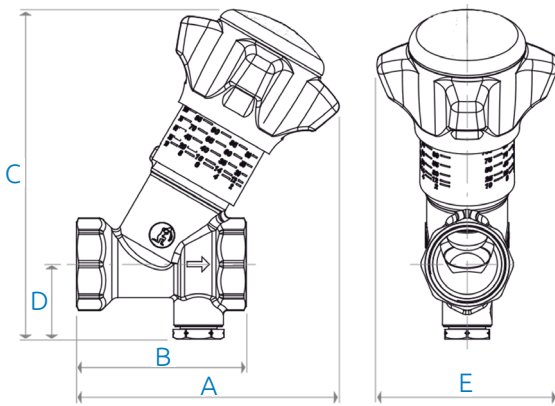
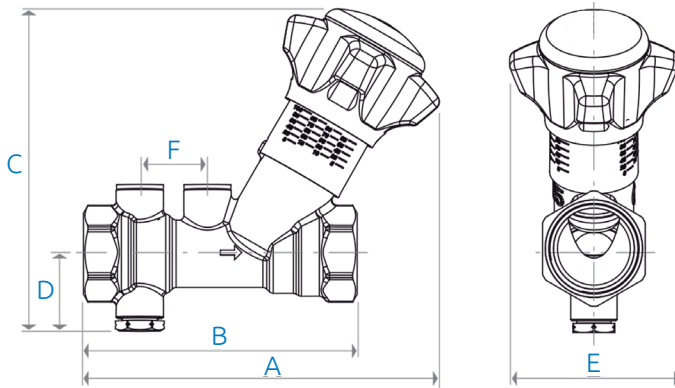

\* 1/2" LF Model

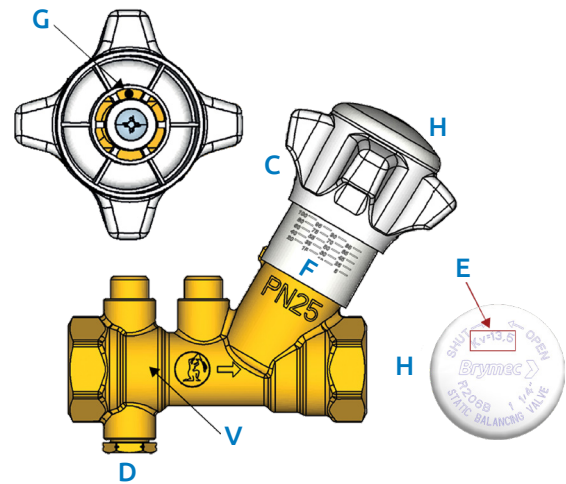

STOCK NO.	CONNECTIONS	A (mm)	B (mm)	C (mm)	D (mm)	E (mm)	F (mm)	Kv
38897	1/2 LF	93	54	117	24	64	-	2.1
38898	1/2"	131	95	119	25	64	25	2.7
38899	3/4"	131	101	118	28	64	25	5.5
38900	1"	131	110	122	32	64	25	7.0
38901	1 1/4"	137	120	129	35	64	25	9.5
38902	1 1/2"	163	140	166	39	64	25	18.8
38903	2"	169	154	172	45	70	25	25.5

ITEM	DESCRIPTION
C	Handwheel
D	Drain 1/4" F
E	Kv of the Venturi flow meter
F	Scale for 0 - 100% setting (20 positions)
G	Presetting screw (limiting the stroke)
H	Removable head (for presetting) with imprinted the Venturi Kv

# F x M Fixed Orifice DZR Brass Metering Station

## COM 06

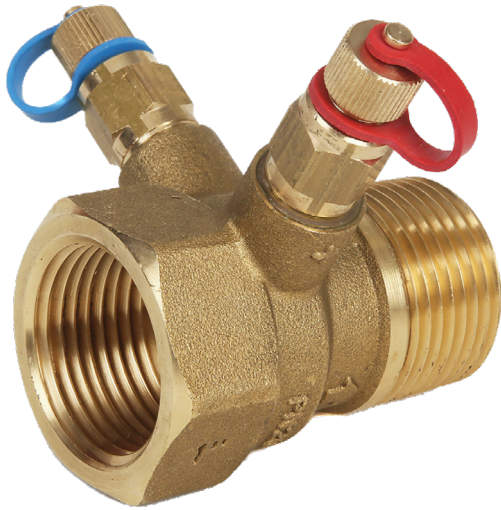

### Technical Data

- Max. Pressure: 20 bar
- Working Temp: -10 to 120°C

### Applicable Standards

- Testing 12266-1
- 1507 BSP taper connections

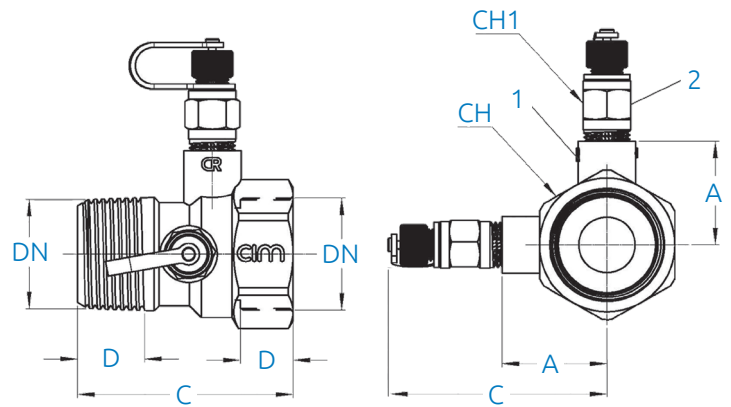

### Features and Benefits

- Screwed BSP taper
- Fixed orifice with  $\pm 5\%$  flow measurement accuracy
- Can be close coupled to a double regulating valve
- Supplied with 2 fitted test points
- $\frac{1}{2}$ " available in Std, Med, Low, Ultra Low and Ultra Ultra Low flow versions

### Material Specifications

NO	NAME	MATERIAL
1	Body	DZR Brass CW602N-M
2	Pressure Test Point	DZR Brass

### Dimensional & Operational Details

STOCK NO.	DN	A	C	D	CH	CH1	Kgs	Kvs
38769	$\frac{1}{2}$ " UUL *	25	67	17	28	14	0.23	0.10
38770	$\frac{1}{2}$ " UL *	25	67	17	28	14	0.23	0.23
38771	$\frac{1}{2}$ " LF *	25	67	17	28	14	0.23	0.47
38772	$\frac{1}{2}$ " MF *	25	67	17	28	14	0.23	0.98
38905	$\frac{1}{2}$ "	25	67	17	28	14	0.23	1.80
38906	$\frac{3}{4}$ "	28	67	17	34	14	0.27	4.06
38907	1"	31	64	19	40	14	0.32	7.45
38908	1 $\frac{1}{4}$ "	36	71	22	51	14	0.47	16.63
38909	1 $\frac{1}{2}$ "	39	71	21	56	14	0.53	23.00
38911	2"	45	80	26	71	14	0.81	47.35

\* Use with  $\frac{1}{2}$ " LF DRV **COM03** to give low flow close coupled commissioning valve option

# Ductile Iron Double Regulating Valve

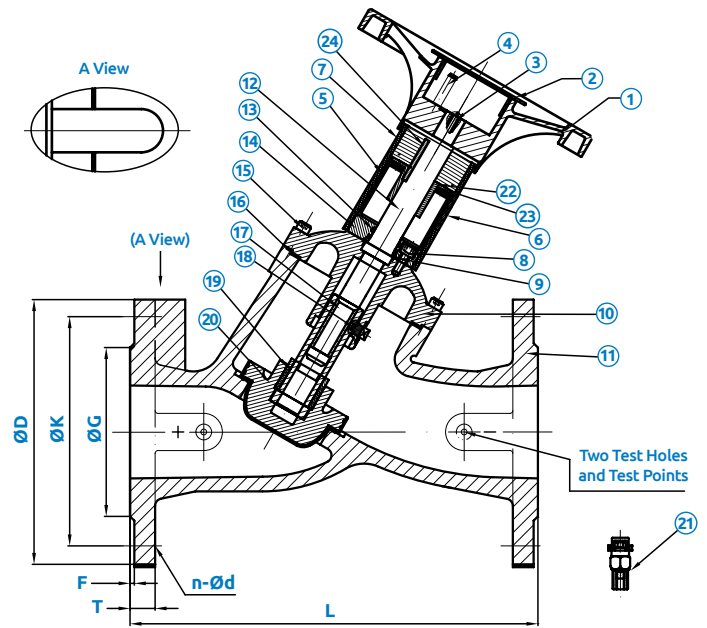

## Features and Benefits

- Position indicator
- Supplied with 2 test points and extensions
- EPDM cone seating gives tight shut off
- Conforms to BS 7350 / BS 5152

## Technical Data

- Max pressure 16 Bar
- Working temp: -20°C to +120°C
- Flange mounting PN16 only
- Flange conforms to BS EN1092 PN16

## Product Codes and Dimensions

STOCK NO	Size	D (mm)	K (mm)	n-Ød (mm)	T (mm)	G (mm)	F (mm)	L (mm)	A (mm)	Kv	Kgs
38777	2"	165	125	4 - 19	19	99	3	230	370	48.2	12.4
38912	2½"	185	145	4 - 19	19	118	3	290	430	82.6	15.8
38913	3"	200	160	8 - 19	19	132	3	310	440	117.4	20.8
38914	4"	220	180	8 - 19	19	156	3	350	470	211.4	29.8
38915	5"	250	210	8 - 19	19	184	3	400	520	381.5	41.7
38916	6"	285	240	8 - 23	19	211	3	480	570	462.4	55.6
38917	8"	340	295	12 - 23	20	266	3	600	730	790.0	125.5
38778	10"	405	355	12 - 28	22	319	3	730	830	1135	194
38779	12"	460	410	12 - 28	24.5	370	4	850	950	2022	288

## Material Specifications

NO	NAME	MATERIAL
1	Handwheel	Aluminium Alloy / Steel
2	Handwheel Cover	Plastic
3	Handwheel Lock Screw	Stainless Steel 304
4	Adjusting Screw	Stainless Steel 304
5	Indication Tube	Plastic
6	Transparent Scale	Plastic
7	Connection Tube	ABS Plastic
8	Hexagon Socket Screw	Carbon Steel
9	O-Ring	EPDM
10	Cover	Cast Iron
11	Body	Ductile Iron
12	Stem	Stainless Steel 410

NO	NAME	MATERIAL
13	O-Ring	EPDM
14	Packing Gland	Stainless Steel 410
15	Hexagon Socket Screw	Carbon Steel
16	Graphite Gland	Graphite
17	Stem Nut	HPb59-1
18	Positional Screw	Stainless Steel 304
19	Nut Cover	HPb59-1
20	Disc wrapped in rubber	Cast Iron + EPDM
21	Test Points	-
22	Drive Plate	Stainless Steel 410
23	Screw	Carbon Steel
24	Flat Key	Stainless Steel 410

# Wafer Pattern Metering Station Orifice COM 02



## Technical Data

- Max. Pressure: 16 bar
- Working Temp: -10 to 120°C

## Applicable Standards

- Fits between BS EN1092 flanges PN16
- Flow characteristic confirmed to BS 7350

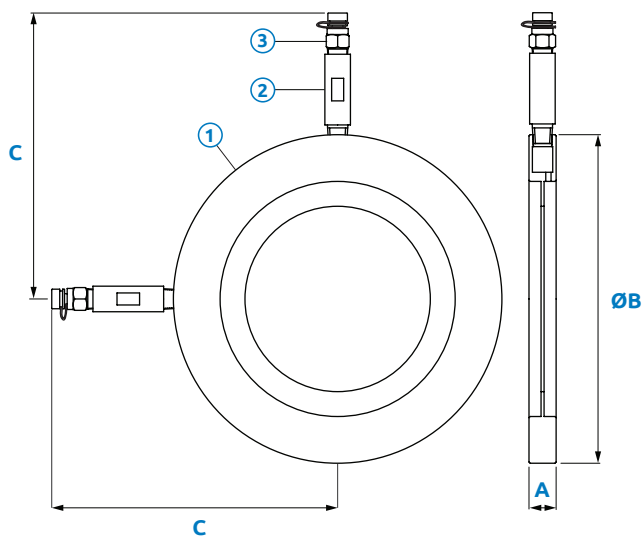
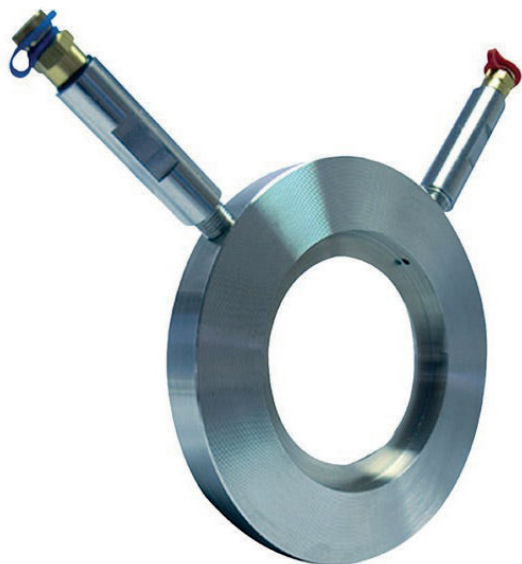

## Features and Benefits

- Stainless Steel Metering Station
- Fixed Orifice. C/W Ext & Test Points
- Wafer pattern
- Fixed orifice with  $\pm 5\%$  flow measurement accuracy
- Can be close coupled to a double regulating valve
- Supplied with 2 extensions and test points

## Material Specifications

NO	NAME	MATERIAL
1	Body	Stainless Steel 304
2	Extension	Stainless Steel 304
3	Pressure Test Point	Brass Hpb59-1

## Product Codes and Dimensions

STOCK NO.	DN	A	B	C	Kgs	Kv (m <sup>3</sup> /hr)	Kv signal*
38773	50	20	108	136	1.3	71.6	57
38918	65	20	127	144	1.8	145.5	104
38919	80	20	144	153	2.1	219.0	137
38920	100	20	164	164	2.5	386.0	241
38921	125	20	194	178	3.0	572.0	345
38922	150	20	220	192	3.4	807.0	516
38774	200	20	275	219	4.5	1416	863
38775	250	20	333	248	6.0	1975	1218
38776	300	20	385	274	8.0	2990	1794

\* Kv signal used when calculating flow rate via differential pressure measurement across tapings

# DZR Brass Commissioning Valve - Press Fit

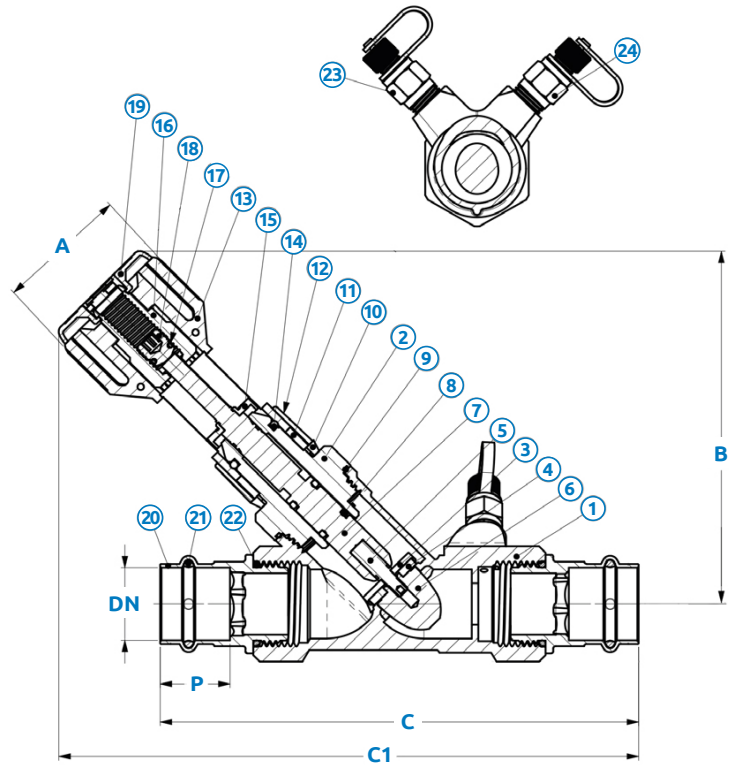

## Features and Benefits

- Press Profile - M"
- Conforms to BS 5154
- Fixed orifice with  $\pm 5\%$  flow measurement accuracy
- 5 year warranty

## Technical Data

- Max pressure:  
DN15 - 24 Bar  
DN22 & DN28 - 20 Bar  
DN 35 to DN54 - 17 Bar
- Working temp: -10°C to +120°C

## Product Codes and Dimensions

STOCK NO	Size	A(mm)	B(mm)	C(mm)	C1(mm)	P(mm)
36339	15mm	51	111	144	192	22
36340	22mm	51	129	165	217	25
36341	28mm	51	138	185	224	27
36342	35mm	51	142	216	245	27
36343	42mm	57	181	248	302	32
36344	54mm	57	190	295	326	37

## Material Specifications

NO	NAME	MATERIAL
1	Body	DZR Brass
2	Bonnet	DZR Brass
3	Gasket Support	DZR Brass
4	Gasket	EPDM
5	Stem for Shutter	DZR Brass
6	Shutter	DZR Brass
7	Stem	DZR Brass
8	Lock Nut	EPDM PEROX
9	Handle	EPDM PEROX
10	Nut	Hostaform
11	Outdistance	Nylon
12	1/10 Turn Index	Hostaform
13	Knob	Hostaform
14	Pin	Steel
15	Index	Hostaform
16	Entrainer	Brass
17	Stem Gaskets O-Ring	NBR 70SH
18	Memory	Brass
19	Cup	Hostaform
20	Adaptor	DZR Brass
21	O-Ring (Delta)	EPDM 70 PEROX
22	O-Ring	EPDM 70 PEROX
23	Binder Point Blue	-
24	Binder Point Red	-

# DZR Brass Double Regulating Valves - Press Fit

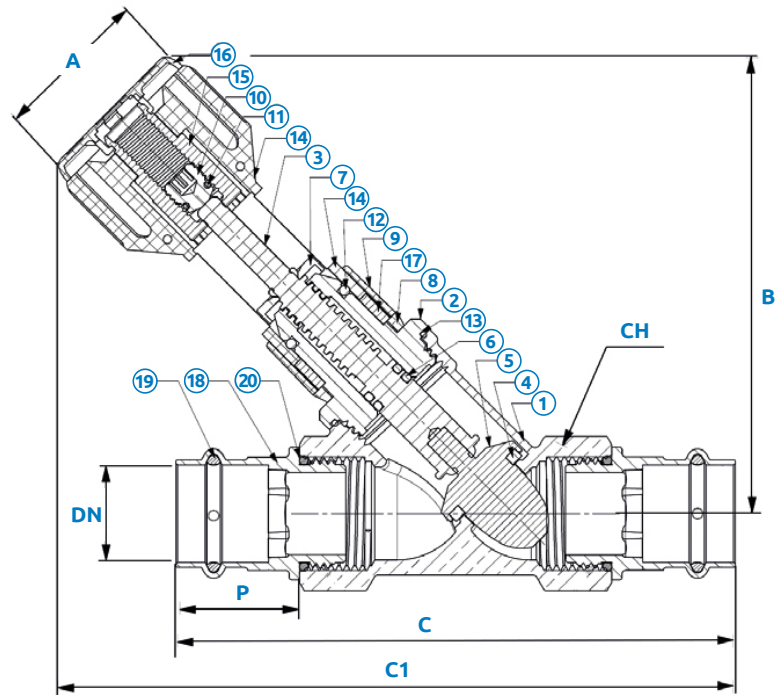

## Features and Benefits

- Press Profile - M"
- Handwheel with shut off function and clear 360° reading
- Conforms to BS 5154
- 5 year warranty

## Technical Data

- Max pressure:  
DN15 to DN28 - 20 Bar  
DN35 to DN54 - 17 Bar
- Working temp: -10°C to +120°C

## Product Codes and Dimensions

STOCK NO	Size	A (mm)	B (mm)	C (mm)	C1 (mm)	P (mm)	CH (mm)
36348	15mm	51	104.5	118	163	22	28
36349	22mm	51	121	136	182.5	25	33
36350	28mm	51	133	148	190	27	40
36351	35mm	51	141	164	199.5	27	51
36352	42mm	57	181	184.5	251	32	56
36353	54mm	57	190	227	278.5	37	71

## Material Specifications

NO	NAME	MATERIAL
1	Body	DZR Brass
2	Bonnet	DZR Brass CW602N
3	Stem	DZR Brass CW602N
4	Gasket	EPDM
5	Shutter	DZR Brass CW602N
6	O-Ring	EPDM PEROX
7	Blue Index	POM
8	Blue Turn Index	POM
9	1/10 Turn Index	POM
10	Memory	Brass CW617N
11	Stem Gasket O-Ring	NBR 70Sh
12	Pin	Steel
13	O-Ring	EPDM PEROX
14	Knob	PA6 Fiberglass (15%)
15	Entrainer	Brass CW617N
16	Cap Blue	POM
17	Thickness	Nylon
18	Joint	DZR Brass CW511L
19	O-Ring	EPDM PEROX
20	O-Ring	EPDM PEROX



# Differential Pressure Control Valve

## COM 07



### Features & Benefits

- Maintains constant differential pressure with any flow
- Low (L) & high (H) differential pressure ranges as standard
- L mode = 5 - 30 kPa and H mode = 25 - 60 kPa
- Factory set to minimum
- Supplied with 1m capillary for connection to Partner valve
- Return mounted
- Can be installed in horizontal or vertical pipework
- DZR, EPDM wetted parts

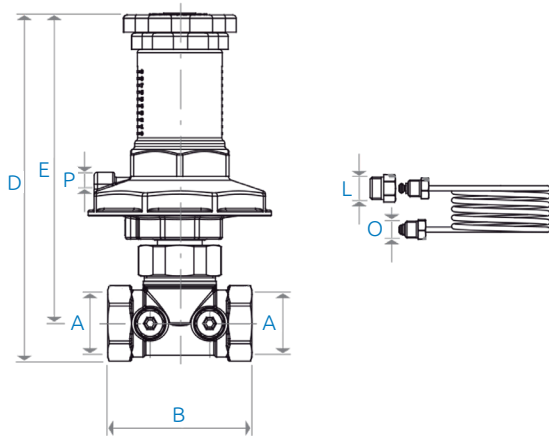

### Technical Data

- Compatible Fluids: Water, glycol-based solutions (max. 50% of glycol)
- Temp. Range: 5 - 110 °C (-20 - 110 °C with anti-freezing glycol)
- Max. Working Pressure: 16 bar
- Max. Differential Pressure: 6 bar
- Setting of Differential Pressure Range: "L" setting = 5 - 30 kPa; "H" setting = 25 - 60 kPa
- Connections for pressure outlets: 1/4" F (Rp - EN 10226)
- Connections for copper capillary: 1/8" F (Rp - EN 10226)

### Materials

- Body and internal components: brass EN12165 - CW602N (DZR)
- Other components not in contact with water: brass EN12165 - CW617N
- Membrane: EPDM with nylon reinforcement
- O-Ring: EPDM
- Springs: galvanized steel
- Plastic components: PA 6 GF15 and POM
- Capillary pipe: copper

### Main Components

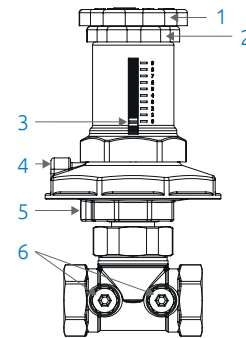

NO	DESCRIPTION
1	Adjustment knob
2	Knob-removing ring nut
3	Indicator ring with graded scale
4	Connection to capillary pipe
5	Air-purging screw
6	Pressure outlets

### Versions and Products Codes

STOCK NO	A	B	D	E	F	L	O	P	Kv
36548	1/2" F	65	185	170	108	R 1/4" M	R 1/8" M	Rp 1/8" F	2.24
36550	3/4" F	75	188	170	108	R 1/4" M	R 1/8" M	Rp 1/8" F	3.49
36554	1" F	85	202	181	108	R 1/4" M	R 1/8" M	Rp 1/8" F	5.92
36555	1 1/4" F	95	208	181	108	R 1/4" M	R 1/8" M	Rp 1/8" F	6.95
36556	1 1/2" F	100	220	192	108	R 1/4" M	R 1/8" M	Rp 1/8" F	11.72
36558	2" F	130	227	192	108	R 1/4" M	R 1/8" M	Rp 1/8" F	12.97

# Isolating Ball Valve

## ISO 04



### Features & Benefits

- Chrome isolating valve with compression ends
- WRAS approved
- Non-shock, use only fully opened or closed

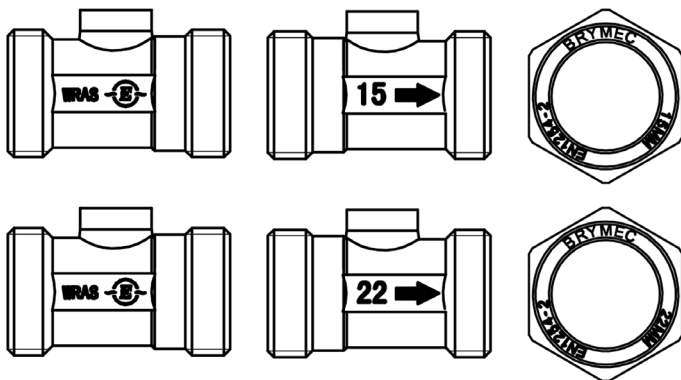

### Technical Data

- Fields of Applications: Water
- Max. Working Pressure: PN16
- Operating Temp. Range: -10 to + 85°C

### Applicable Standards

- Compression connections comply with: EN1254-2
- Valves are manufactured to BS6675
- WRAS Approved

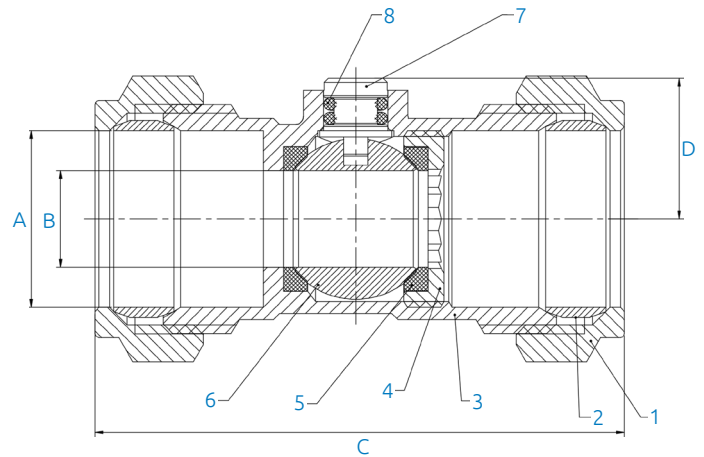

### Versions & Product Codes

STOCK NO.	DN	A	B	C	D
36372	15	15	8	51.6	15.5
36373	22	22	12	66	18

### Material Specifications

NO	NAME	MATERIAL	QUANTITY
1	Compression Nut	HPb59- T	2
2	Olive	T2 Copper	2
3	Body	HPb59- T	1
4	Catch Spring	SUS304	1
5	O-Ring	NBR	2
6	Ball	HPb59- T	1
7	Stem	HPb59- T	1
8	O-Ring	EPDM	2

# Dual Double Check & Isolating Valve

## ISO 02



### Features & Benefits

- Combined Double Check & Isolation Valve
- Space saving with reduced connections
- Non-shock, use only fully opened or closed

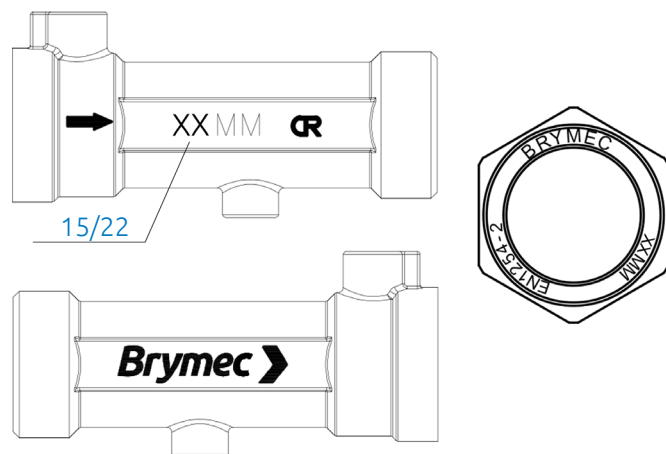

### Technical Data

- Fields of Applications: Water
- Max. Working Pressure: PN16
- Operating Temp. Range: -10 to + 85°C

### Applicable Standards

- Compression connections comply with: EN1254-2
- WRAS Approved

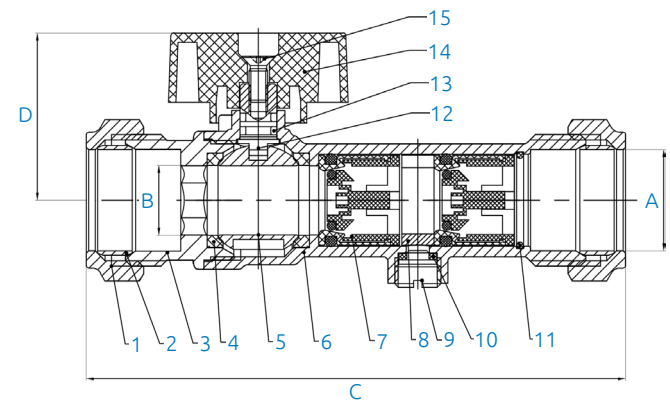

### Versions & Product Codes

STOCK NO.	WRAS	DN	A	B	C	D
30882	Yes	15	15	10	101	32.7
30889	No	22	22	15	115	39

### Material Specifications

NO	NAME	MATERIAL	QUANTITY	
1	Compression nut	HPb59- T	2	NP
2	Olive	T2 copper	2	-
3	Bonnet	CW602N	1	NP
4	Seat	PTFE	1	-
5	Ball	HPb59- T	1	CP
6	Body	CW602N	1	NP
7	Non-Return Core	POM	2	-
8	O-ring	NBR	1	-
9	Screw	Q235	1	-
10	Catch Spring	SS304	1	-
11	Plastic Ring	Nylon	1	-
12	O-ring	NBR	2	-
13	Stem	HPb59- T	1	NP
14	Handle	Nylon	1	-
15	Screw	Q235	1	-

# Chrome Washing Machine Valve

## ISO 08



### Features and Benefits

- Chrome isolating valve with 15mm compression and 3/4" connections
- WRAS Approved
- Supplied with red and blue levers

### Technical Data

- Fields of applications: Water
- Max working pressure: PN10
- Operating temperature range: -10°C to +85°C

### Applicable Standards

- Compression connections comply with: EN1254-2
- Thread connections: ISO228
- WRAS Approved

### Product Codes and Dimensions

STOCK NO	DN	A (mm)	B (mm)	C (mm)	D (mm)
36378	15	15	8	33.7	30
36379	15	15	8	46	30

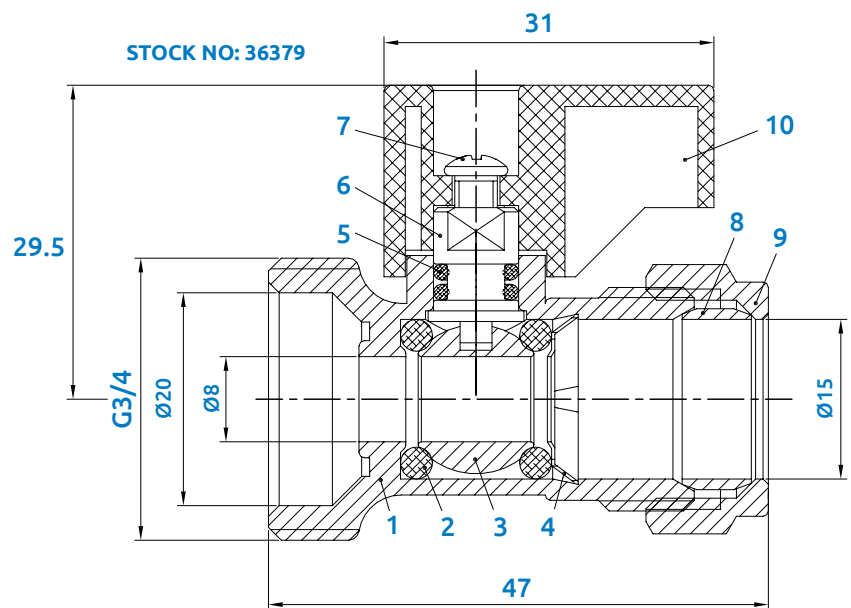
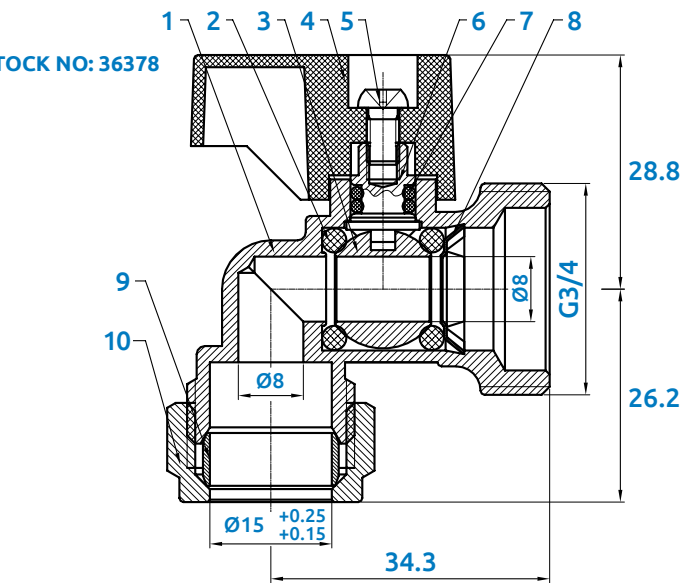

### Material Specifications

NO	NAME	MATERIAL	QTY	OTHER
1	Body	HPb59-T	1	Nickel Plating
2	O-ring	NBR	2	-
3	Ball	HPb59-T	1	Chrome Plated
4	Handle	Plastic	1	Red and Blue
5	Screw	Q235	1	-
6	Stem	HPb59-T	1	-
7	O-ring	EPDM	2	-
8	Catch spring	SS302	1	-
9	Olive	T2 copper	1	-
10	Compression Nut	HPb59-T	1	Nickel Plating

# Isolating Valve with Black Lever Handle

## ISO 01



### Features & Benefits

- Nickel chrome plated brass
- Uni-directional flow
- Non-shock, use only fully opened or closed

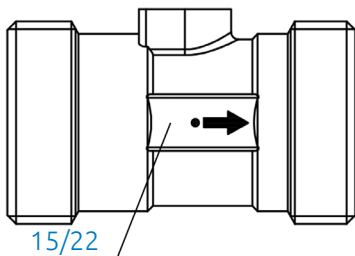
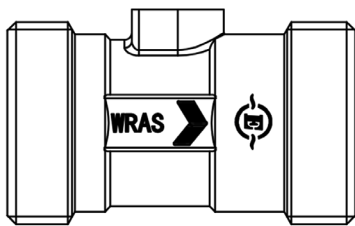

### Technical Data

- Fields of Applications: Water
- Max. Working Pressure: PN10
- Operating Temp. Range: -10 to + 85°C

### Applicable Standards

- Valves are manufactured in accordance with: BS6675
- Compression connections comply with: EN1254-2
- WRAS Approved

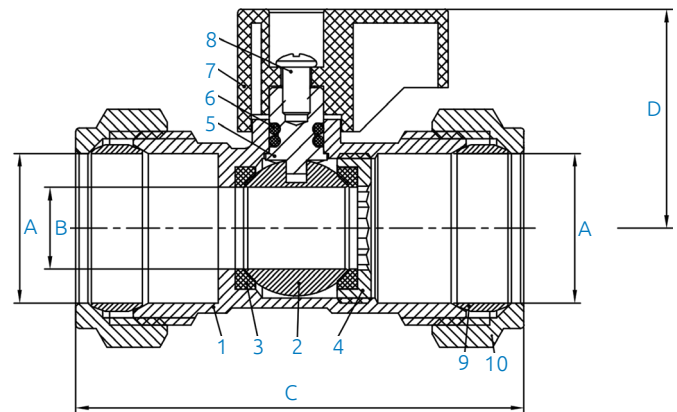

### Versions & Product Codes

STOCK NO.	DN	A	B	C	D
30840	15	15	8	49.5	30.2
30841	22	22	12	66	32.2

### Material Specifications

NO	NAME	MATERIAL	QUANTITY	
1	Body	HPb59- T	1	NP
2	Ball	HPb59- T	1	CP
3	Ball Seat	PU	2	-
4	Lock Nut	HPb59- T	1	-
5	Stem	HPb59- T	1	-
6	O-ring	EPDM	2	-
7	Handle	ABS	1	-
8	Screw	Q235	1	-
9	Olive	T2 copper	2	-
10	Compression nut	HPb59- T	1	NP

# Full Bore Chrome Isolating Valve ISO 03



## Features & Benefits

- Chrome isolating valve with compression ends
- WRAS approved heavy pattern
- Non-shock, use only fully opened or closed

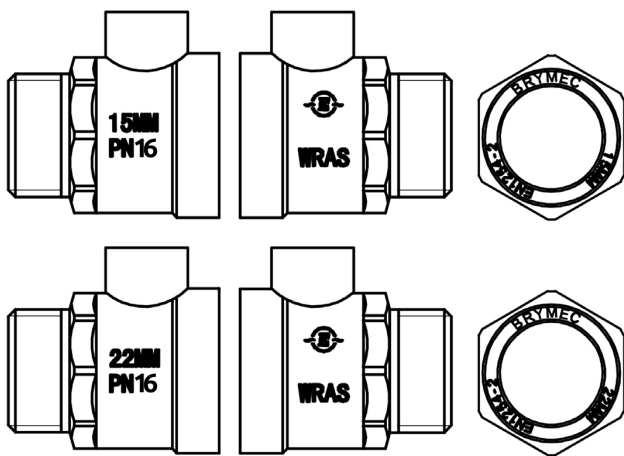

## Versions & Product Codes

STOCK NO.	DN	A	B	C	D
30833	15	15	13.5	67	22.8
30834	22	22	19	69	27

## Technical Data

- Fields of Applications: Water
- Max. Working Pressure: PN10
- Operating Temp. Range: -10 to + 90°C

## Applicable Standards

- Compression connections comply with: EN1254-2
- Valves are manufactured to BS6675
- WRAS Approved

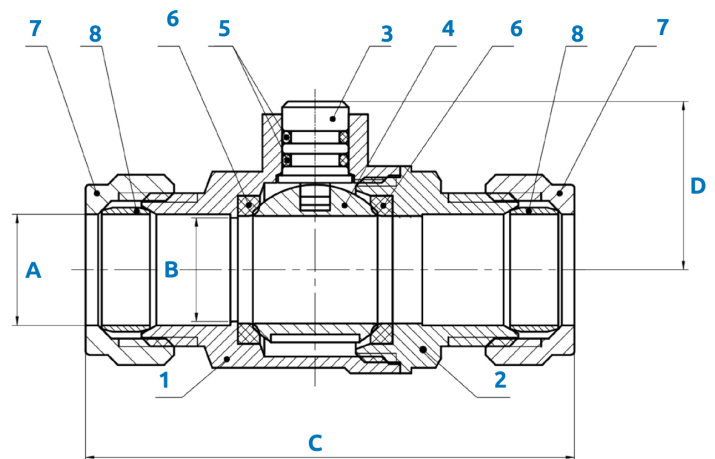

## Material Specifications

NO	NAME	MATERIAL	QUANTITY
1	Body	HPb59- 3	1
2	Bonnet	HPb58- 2	1
3	Sealing	PTFE (WRAS approval)	2
4	Ball	HPb56- 4	1
5	Stem	HPb58- 2	1
6	O-Ring	EPDM (WRAS approval)	2
7	Olive	T2	2
8	Hexagonal Nuts	HPb59- 3	2

# Angled Isolating Valve

## Chrome Compression Ends

### ISO 05



### Features & Benefits

- Chrome isolating valve with compression ends
- Angled pattern reducing space, connections and leak paths
- Non-shock, use only fully opened or closed

### Versions & Product Codes

STOCK NO.	SIZE
36374	15 x 15mm

### Technical Data

- Fields of Applications: Water
- Max. Working Pressure: PN16
- Operating Temp. Range: -10 to + 85°C

### Applicable Standards

- Compression connections comply with: EN1254-2
- Valves are manufactured to BS6675
- WRAS Approved

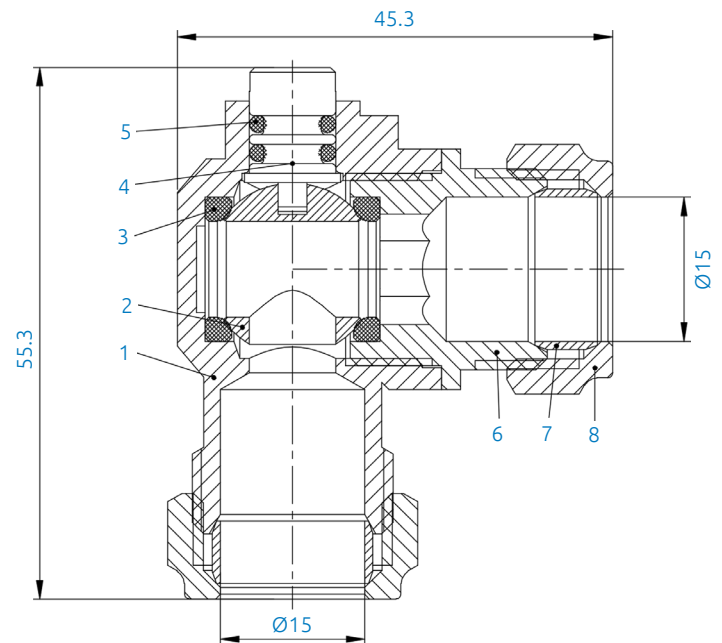

### Material Specifications

NO	NAME	MATERIAL	QUANTITY
1	Body	HPb59- T	1
2	Ball	HPb59- T	1
3	Seat	PTFE	2
4	Stem	HPb59- T	1
5	O-Ring	EPDM	2
6	Bonnet	HPb59- T	1
7	Compression nut	HPb59- T	2
8	Olive	T2 Copper	2

# Straight Service Valve

## ISO 06



### Features & Benefits

- Straight chrome service valve
- ¼ turn screwdriver operation
- WRAS approved

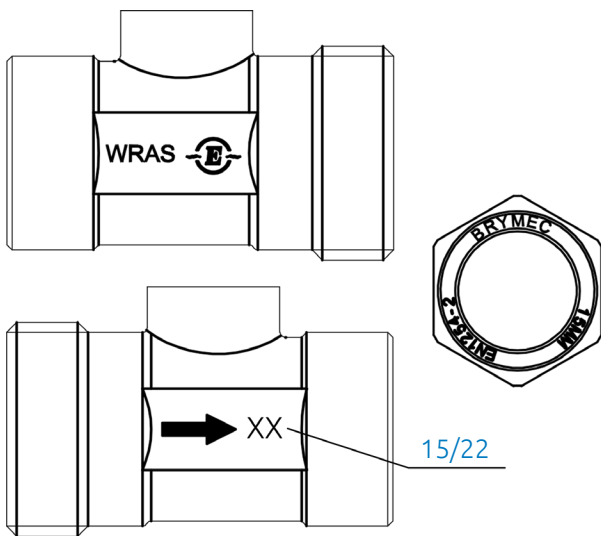

### Technical Data

- Fields of Applications: Water
- Max. Working Pressure: PN10
- Operating Temp. Range: -10 to + 85°C

### Applicable Standards

- Compression connections comply with: EN1254-2
- Valves are manufactured to BS6675
- Female thread connections are to ISO228
- WRAS Approved

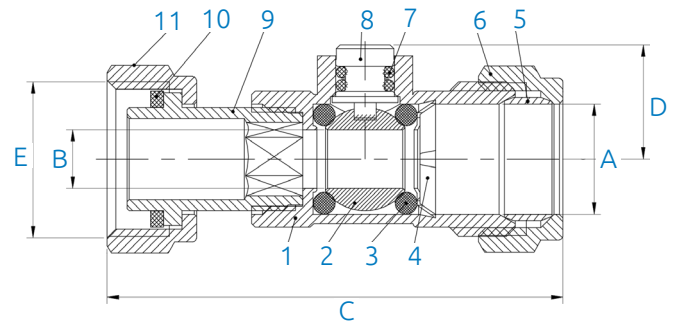

### Material Specifications

NO	NAME	MATERIAL	QUANTITY
1	Body	HPb59- T	1
2	Ball	HPb59- T	1
3	O-Ring	NBR	2
4	Circlip	SUS304	1
5	Olive	T2 Copper	1
6	Compression Nut	HPb59- T	1
7	O-Ring	EPDM	2
8	Stem	HPb59- T	1
9	Connecting Pipe	HPb59- T	1
10	Washer	Red Paper	1
11	Connecting Nut	HPb59- T	1

### Versions & Product Codes

STOCK NO.	DN	A	B	C	D	E
36375	15	15	8	62.2	15.5	½"
30863	22	22	12	71	17.5	¾"



# Compression Isolating Angled Service Valve ISO 07



## Technical Data

- Fields of Applications: Water
- Max. Working Pressure: PN10
- Operating Temp. Range: -10 to + 85°C

## Applicable Standards

- Compression connections comply with: EN1254-2
- Valves are manufactured to BS6675
- Female thread connections are to ISO228
- WRAS Approved



## Features & Benefits

- Angled chrome isolating service valve
- Angled pattern reducing space, connections and leak paths
- Suitable for hot and cold water
- Non-shock, use only fully opened or closed

## Versions & Product Codes

STOCK NO.	DN
36377	15mm x 1/2"

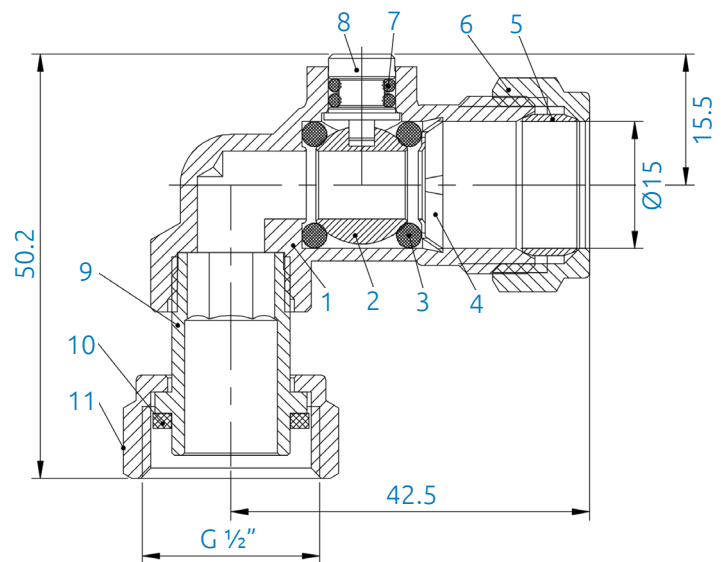

## Material Specifications

NO	NAME	MATERIAL	QUANTITY
1	Body	HPb59- T	1
2	Ball	HPb59- T	1
3	O-Ring	NBR	2
4	Circlip	SUS304	1
5	Olive	T2 Copper	1
6	Compression Nut	HPb59- T	1
7	O-Ring	EPDM	2
8	Stem	HPb59- T	1
9	Connecting Pipe	HPb59- T	1
10	Washer	Red Paper	1
11	Connecting Nut	HPb59- T	1

# TMV3 Mixing Valve

## TMV 01



### Features and Benefits

- Cold water supply temperature 5°C - 25°C
- Hot water supply temperature 55°C - 65°C
- Temperature adjustment range 30°C - 50°C
- Factory set thermostatic controller 42°C 0/2°C
- Accuracy of outlet temperature  $\pm 2^\circ\text{C}$
- Min. temperature differential 12°C (between hot supply and outlet temp)
- Supply pressure imbalance dynamic 2:1
- Flow rate minimum 5 Litres/min
- WRAS Approved
- Certified to TMV2 and TMV3

### Technical Data

- Static Pressure: 10 Bar
- Dynamic Pressure: 5 Bar
- Temperature Adjustment Range: 30°C - 50°C

### Stock No and Dimensions

Stock Code	DN Size	A	B	C	D	E
30964	ø15	ø15.1	59	131	108	50.9
30966	ø22	ø22.1	61	155	110	50.9

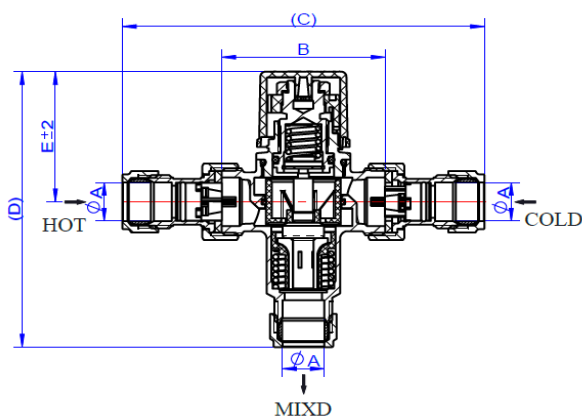

### Material Specifications

No.	Name	Material	QTY.
1	Union nut	CW602N, chrome plated	3
2	Sleeve	CW507L	3
3	Union nut	CW617N, chrome plated	2
4	Pipe Connector	CW602N, chrome plated	2
5	Strainer	Stainless steel	2
6	Check valve	Element, WRAS approved	2
7	Gasket	EPDM, WRAS approved	2
8	Valve body	CW602N, chrome plated	1
9	Spring	Stainless steel	1
10	Water flow directors	PSU	1
11	Thermostat	Subassembly	1
12	O-ring	EPDM, WRAS approved	1
13	Piston	PSU	1
14	Circlip	Stainless steel	1
15	Block	CW602N	1
16	Spring	Stainless steel	1
17	O-ring	EPDM, WRAS approved	1
18	Stem	CW602N	1
19	O-ring	EPDM, WRAS approved	1
20	Bonnet	CW602N, chrome plated	1
21	Locating ring	POM+25%GF	1
22	Locking cap	CW617N	1
23	Cap	ABS	1

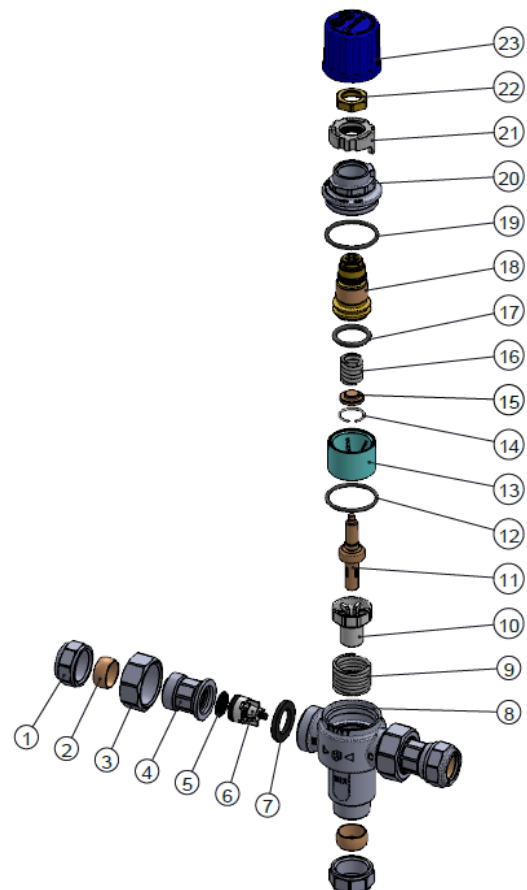

# TMV3 Mixing Valves with Service Valve

## TMV 01SV



### Features and Benefits

- Cold water supply temperature 5°C - 25°C
- Hot water supply temperature 55°C - 65°C
- Temperature adjustment range 30°C - 50°C
- Factory set thermostatic controller 42°C 0/2°C
- Accuracy of outlet temperature  $\pm 2^\circ\text{C}$
- Min. temperature differential 12°C (between hot supply & outlet temp)
- Supply pressure imbalance dynamic 2:1
- Flow rate minimum 5 Litres/min
- WRAS Approved
- Certified to TMV2 and TMV3

**Approvals:** TMV2 NSF2254/012 and TMV3 NSF2255/0120

### Technical Data

- Static Pressure: 10 Bar
- Dynamic Pressure: 5 Bar
- Temperature Adjustment Range: 30°C - 50°C

### Stock No and Dimensions

Stock Code	DN Size	A	B	C	D	E	F	G
30962	ø15	ø15.1	59	128	200	36	82	108
30963	ø22	ø22.1	61	129	201	38	86	110

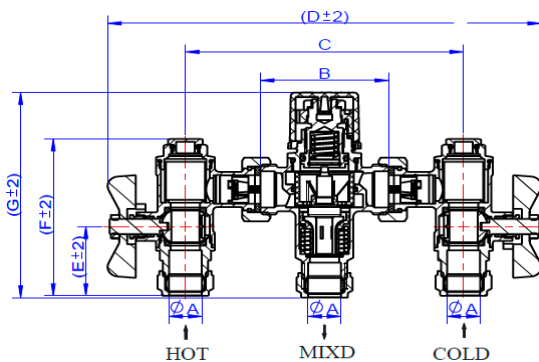

### Material Specifications

No.	Name	Material	QTY.
1, 9,	Lever	Aluminium alloy (RAL3020)	2
2, 19	Union nut	CW602N, chrome plated	5
3	Sleeve	CW507L	3
4, 15, 34	Bonnet	CW602N, chrome plated	5
5	Seat	PTFE, WRAS approved	4
6	Ball	CW602N, chrome plated	2
7	Body	CW602N, chrome plated	2
8	Locknut	Steel, dacromet plated	2
10	Packing nut	CW617N	2
11	Packing	PTFE, WRAS approved	2
12, 32	Stem	CW602N	3
13	Screen	Stainless steel	2
14, 16, 26, 31, 33	O-ring	EPDM, WRAS approved	7
17	Plug	CW602N, chrome plated	2
18	Check valve	Element, WRAS approved	2
20, 28	Circlip	Stainless steel	3
21	Gasket	EPDM, WRAS approved	2
22	Valve body	CW602N, chrome plated	1
23, 30	Spring	Stainless steel	2
24	Water flow directors	PSU	1
25	Thermostat	Subassembly	1
27	Piston	PSU	1
29	Block	CW602N	1
35	Locating ring	POM+25%GF	1
36	Locking cap	CW617N	1
37	Cap	ABS	1

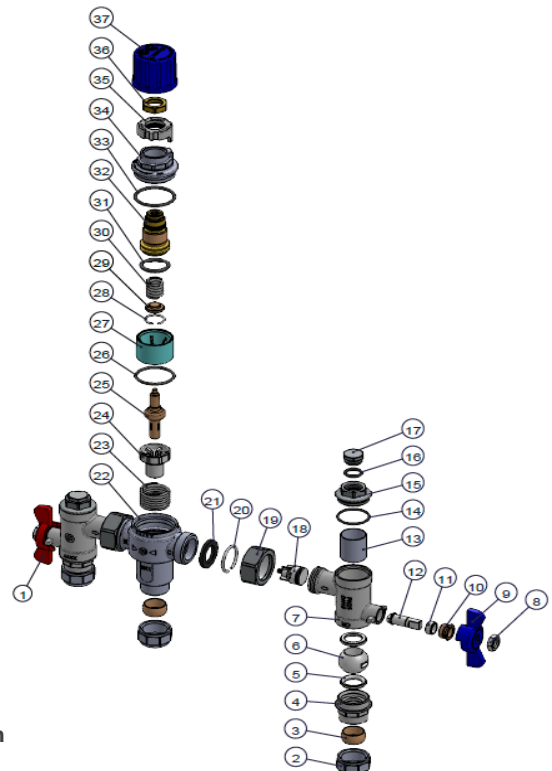

# Thermal Balancing Valve

## - F x F

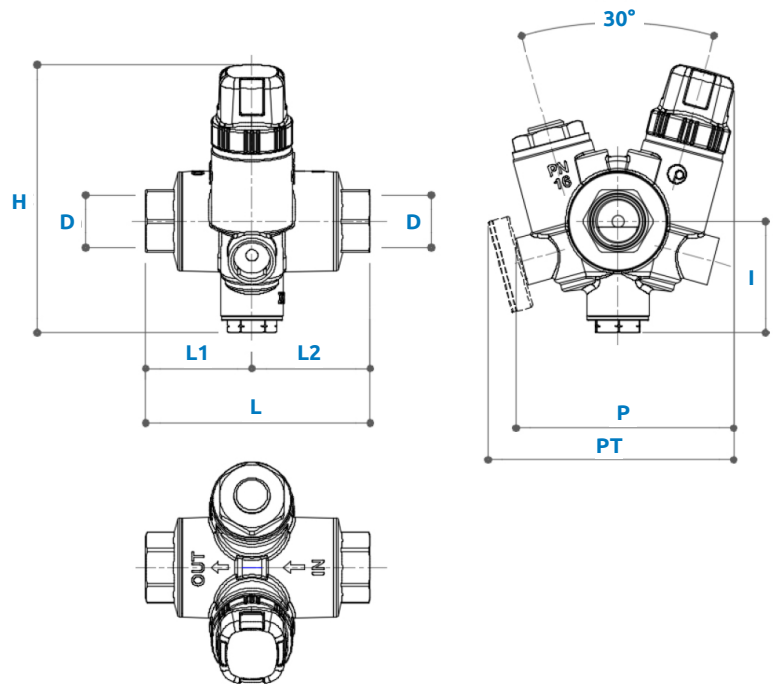

### Features and Benefits

- Thermal balancing with flow regulation via hot water temperature
- Easy temperature adjustment between 35 - 60°C and temperature proof cap
- Equipped with Thermal element for automatic anti legionella treatment
- Drywell thermometer - no need to drain

### Technical Data

- Max working pressure 16 bar
- Maximum Differential Pressure 1 bar
- Max working temperature 90°C
- Temperature setting range 35°- 60°C
- Disinfection Temperature 70°C
- Accuracy  $\pm 2^{\circ}\text{C}$
- Default Presetting 52°C
- $K_{vmax}$  1,8
- $K_{disinf}$  ( by-passC ) 1
- $K_{vmin}$  (  $T > 75^{\circ}\text{C}$  ) 0,2

### Product Codes and Dimensions

STOCK NO	Size	L(mm)	L1(mm)	L2(mm)	H(mm)	I(mm)	P(mm)	PT(mm)	Weight(gr)
30960P	3/4"	99	47	52	112	46	91	102	955
30961P	1/2"	93	44	49	112	46	91	102	950

Dimension mm - PT = with Optional thermometer – drywell 1/2"M

### Material Specifications

NAME	MATERIAL
Body	CW511L (EN 12165)-CuZn38As-ASTM C27453
Fitting	CW511L (EN 12165)-CuZn38As-ASTM C27453
Cap	CW511L (EN 12165)-CuZn38As-ASTM C27453
O-ring	EPDM-X
Protection Handwheel	PA66
Presetting Handwheel	ABS
Spring	AISI302
Shutter	PSU

## Kv vs. Temperature Chart

Below is the characteristic operating diagram of the Thermal Balancing FxF Valve which shows the Kv value as a function of the temperature of the water passing through the valve and the presetting value selected.

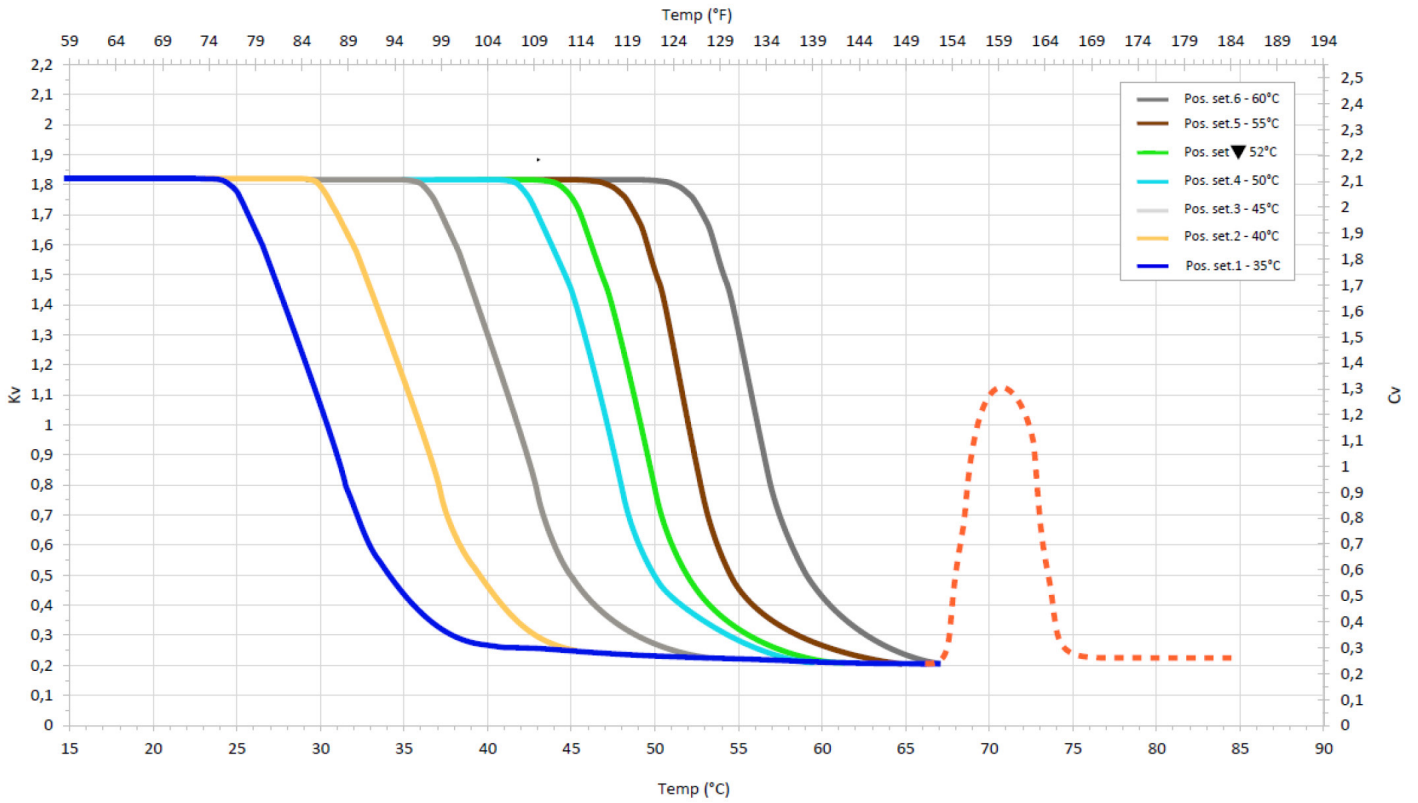

# Compression Double Check Valve DZR Brass NRV 05



## Features and Benefits

- Double check valves when fitted stop the flow of water in one direction preventing back flow
- DZR Brass body with compression ends for copper pipework
- Eliminates syphonage contamination
- Space saving over 2 single check valves

## Versions and Products Codes

STOCK NO	SIZE A (mm)	B	C	D
30766	15	25.3	77.1	17
30767	22	35	88.6	20
30768	28	41	112.1	24.5

## Technical Data

- Fields of Applications: Water
- Max. Working Pressure: PN10
- Operating Temp. Range: -10 to +85°C

## Applicable Standards

- Valves are manufactured to: BS6282-1
- Compression connections comply with: EN1254-2
- WRAS approved

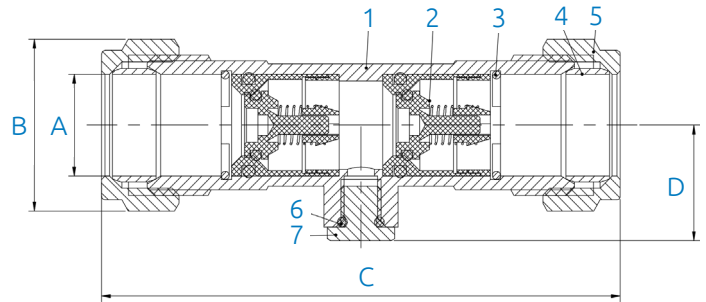

## Material Specifications

NO	NAME	MATERIAL	QUANTITY	MATERIAL
1	Body	CW602N	1	DZR Brass
2	Non-return core	POM	2	-
3	Catch spring	SUS304	1	-
4	Olive	T2 Copper	2	-
5	Compression nut	HPb59- T	2	NP/Brass
6	O-ring	NBR	1	-
7	Screw	HPb59- T	1	NP/Brass

# Compression Double Check Valve Chrome

## NRV 07



### Features and Benefits

- Double check valves when fitted stop the flow of water in one direction preventing back flow
- Copper Plated
- Brass body with Compression ends for copper pipework systems
- Eliminates Syphonage Contamination
- Space saving over 2 single check valve

### Versions and Products Codes

STOCK NO	SIZE A (mm)	B	C	D
30773	15	25.3	77.1	17
30774	22	35	88.6	20
30791	28	41	112.1	24.5

### Technical Data

- Fields of Applications: Water
- Max. Working Pressure: PN10
- Operating Temp. Range: -10 to +85°C

### Applicable Standards

- Valves are manufactured to: BS6282-1
- Compression connections comply with: EN1254-2
- WRAS approved

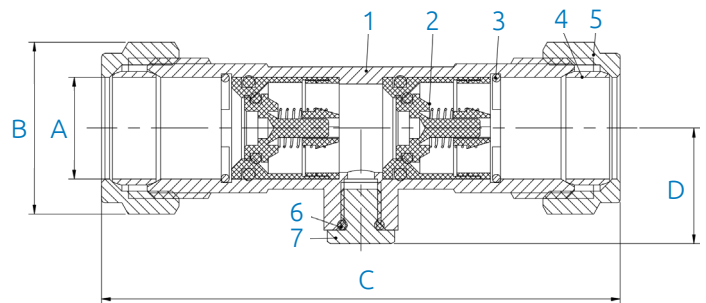

### Material Specifications

NO	NAME	MATERIAL	QUANTITY	MATERIAL
1	Body	CW602N	1	CP/Brass
2	Non-return core	POM	2	-
3	Catch spring	SUS304	1	-
4	Olive	T2 Copper	2	-
5	Compression nut	HPb59- T	2	CP/Brass
6	O-ring	NBR	1	-
7	Screw	HPb59- T	1	NP/Brass

# Compression Double Check Valve Bronze

## NRV 06



### Features and Benefits

- Double check valves when fitted stop the flow of water in one direction preventing back flow.
- Bronze body with compression ends for copper pipework systems.

### Technical Data

- Fields of applications: water
- Max working pressure: PN16
- Operating temperature range: -5°C to +60°C

### Applicable Standards

- Compression connections comply with EN1254-2

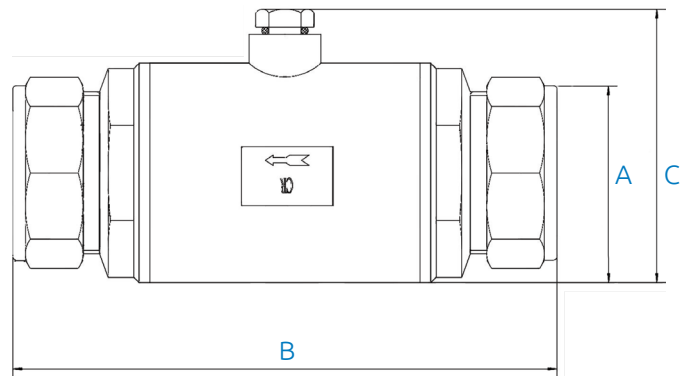

### Versions and Products Codes

STOCK NO	A	B	C
30711	35	149	74.5
30712	42	165	83
30713	54	175	97

### Material Specifications

ITEM	PARTS	MATERIAL	QTY
1	Brass	C83600	1
2	Filter	ABS Plastic	1
3	Seals	NBR rubber	2



# DZR Brass Double Check Valve

## NRV 04



### Features and Benefits

- Double check valves when fitted stop the flow of water in one direction preventing back flow
- DZR Brass body with BSP female connections
- Eliminates syphonage contamination
- Space saving over 2 single check valves

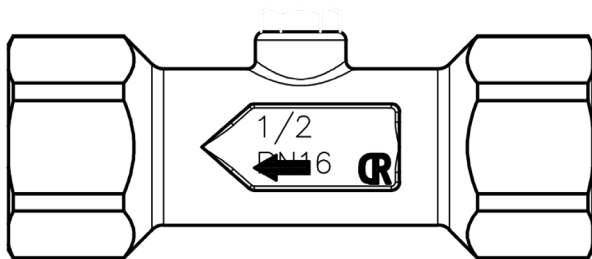
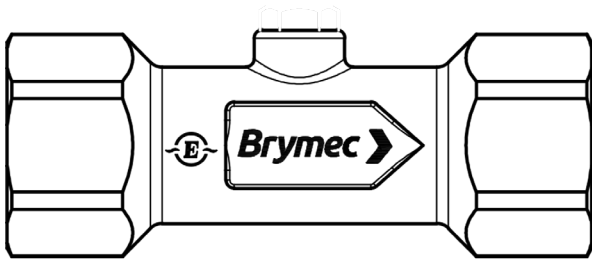

### Technical Data

- Fields of applications: water
- Maximum working pressure: PN16
- Maximum working temperature: 90°C

### Applicable Standards

- BSP parallel ISO 228/1 connections
- WRAS approved
- Contamination risk protection category 3

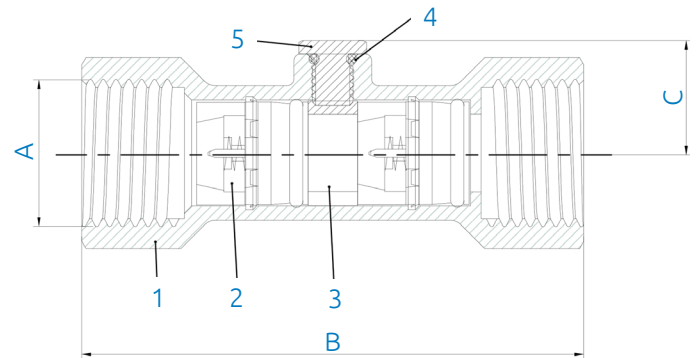

### Material Specifications

ITEM	PARTS	MATERIAL	QUANTITY	OTHER
1	Body	CW602N	1	DZR Brass
2	Non Return Core	POM	2	-
3	Baffle Ring	H62	1	-
4	O-ring	NBR	1	-
5	Screw	HPb59-T	1	NP/Brass

### Versions and Products Codes

STOCK NO	DN	A	B	C
36366	1/2"	G 1/2	71	16.5
36367	3/4"	G 3/4	83	19
36368	1"	G 1	98	22
36369	1 1/4"	G 1 1/4	118	25
36370	1 1/2"	G 1 1/2	134	29
36371	2"	G 2	173	34

# Bronze Swing Check Valve

## NRV 01



### Technical Data

- Max. Pressure: 20 Bar
- Working Temp: -10°C to +180°C

### Applicable Standards

- BS 5154 (BS EN12288)
- BSP taper connection (ISO7/1)

### Features and Benefits

- Bronze Body and Disc
- PN20 Rated
- Metal Faces
- High temperature application

### Pressure - Temperature Diagram

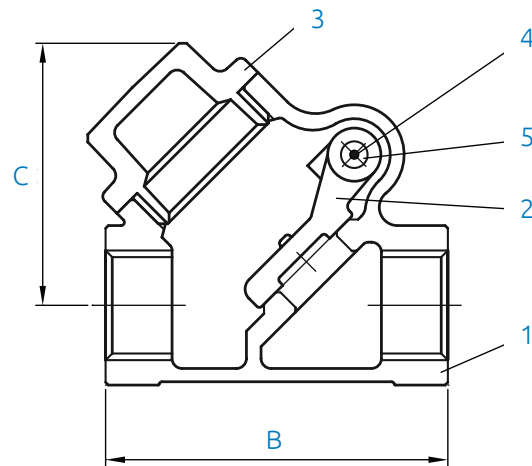
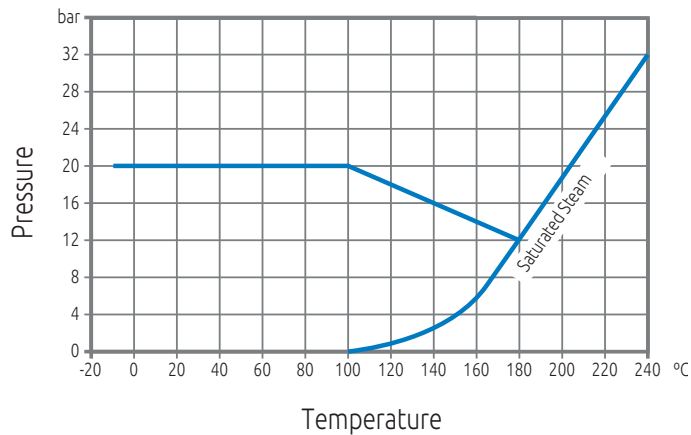

### Material Specifications

NO	NAME	MATERIAL
1	Body	Bronze
2	Disc	Bronze
3	Cap	Bronze
4	Hanger pin	Brass
5	Plug	Brass

### Dimensions

STOCK NO.	DN	B	C	CV	WEIGHT (kg)
38877	½"	56.0	43.0	3.5	0.28
38878	¾"	71.0	51.0	6.6	0.43
38879	1"	80.0	58.0	12.0	0.59
38880	1 ¼"	97	68	22.0	0.91
38881	1 ½"	110	78	30.0	1.31
38882	2"	129	96	50.0	1.86

# Compression Single Check Valve Brass

## NRV 08



### Features and Benefits

- Single check valve with compression ends
- Brass Colour
- Flow directional
- WRAS marking on body

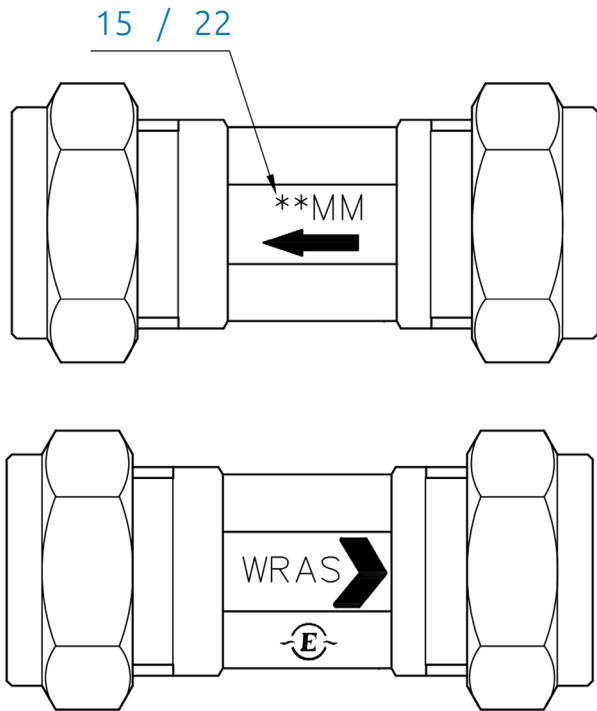

### Technical Data

- Fields of Applications: Water
- Max. Working Pressure: PN10
- Operating Temp. Range: -10 to +85°C

### Applicable Standards

- Valves are manufactured to: BS6282-1
- Compression connections comply with: EN1254-2
- WRAS approved

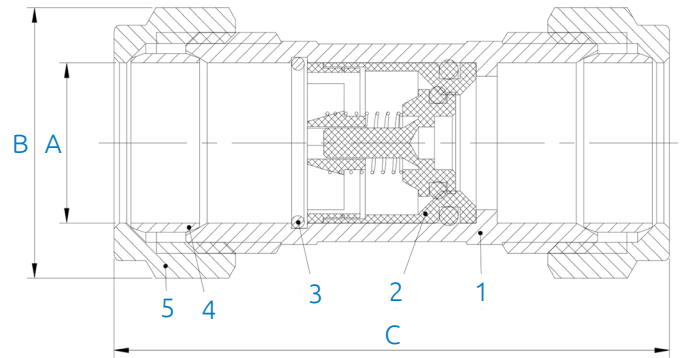

### Material Specifications

NO	NAME	MATERIAL	QUANTITY
1	Body	HPb59-T	1
2	Non-return core	POM	1
3	Catch spring	SUS 304	1
4	Olive	T2 Copper	2
5	Compression nut	HPb59- T	2

### Versions and Products Codes

STOCK NO	SIZE (mm)	A	B	C
30780	15	15	25.3	52.5
30781	22	22	35	64

# Brass Spring Check Valve (Non-Return)

## NRV 02



### Features and Benefits

- Non resilient disc facing with spring assistance for rapid closure
- Installation in horizontal or vertical pipework with the flow in the upwards direction
- Unidirectional
- Spring assistance gives rapid closure, preventing flow reversal and hydraulic shock.
- Ideally suitable for use in heating system.
- Close coupled to a foot filter creates a foot valve and strainer for use in tanks and reservoirs.

### Pressure Diagram

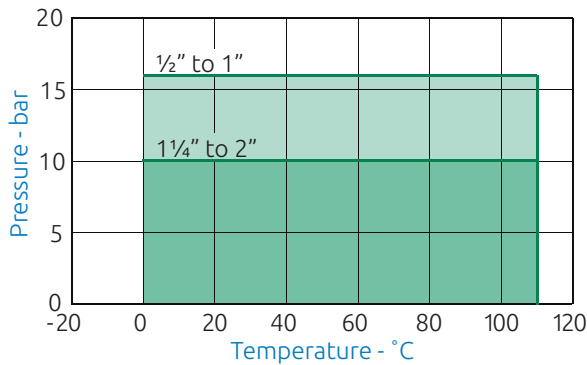

### Versions & Product Codes

STOCK NO.	SIZE	A	B	C	WEIGHT (kg)
36310	1/2"	G1/2	30	45	0.10
36311	3/4"	G3/4	37	53	0.16
36312	1"	G1	44	59	0.23
36313	1 1/4"	G1 1/4	56	66	0.35
36314	1 1/2"	G1 1/2	63	71	0.47
36315	2"	G2	78	80	0.71

### Technical Data

- Max. Temp: 110°C
- Max. Pressure - 1/2" to 1": 16 bar
- Max. Pressure - 1 1/4" to 2": 10 bar
- Min. Opening Pressure: 0.02 bar
- Suitable for water, oil and other industrial services

### Applicable Standards

- Supplied with female parallel threaded ends complying with BS EN ISO 228-1

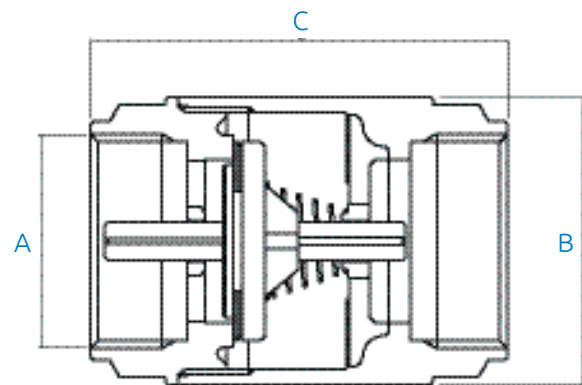

### Material Specifications

COMPONENT	MATERIAL	GRADE
Body	Brass	BS EN 12165 CW617N
Disc	-	POM plastic
Retainer & guide	POM plastic	-
Disc facing ring	NBR rubber	-
Ring retainer	Brass	BS EN 12165 CW617N
Spring	Stainless Steel	AISI 302

# Swing Check Valve

## CIV 04



### Technical Data

- Size: DN50 - DN300 (2" - 12")
- Nominal pressure: PN 16
- Temperature range: 0°C - 80°C
- Suitable for: Water

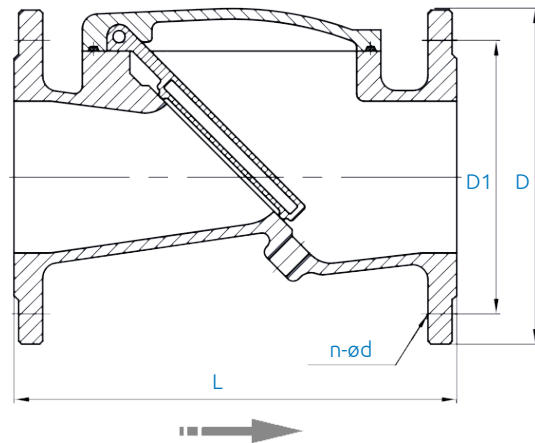

### Features and Benefits

- Concise design, solid structure
- Flexible EPDM vulcanised on the disc assures positive seating at high and low pressures, as well as a long operating life and an extreme resistance to any kind of corrosion.
- 100% unrestricted flow area for improved flow characteristics and lower head loss.
- 15° sealing angle between the disc and seat ensure low pressure sealing.
- Electrostatically applied Akzo Nobel epoxy powder internally and externally.

### Applicable Standards

- Connection standard: BS EN 1092-2
- Pressure test standard: BS EN 12266-2003
- Face to face standard: BS EN558: 2008

### Materials Specifications

NO.	COMPONENT	MATERIAL
1	Body	Ductile Iron JS1040
2	Cone	Ductile Iron JS1040
3	Disc	Steel + Nylon + EPDM Vulcanised
4	Sealing Ring	EPDM

### Swing Check Valve - CVSF

STOCK NO.	SIZE	DN	L	D	D1	N-ØD	WEIGHT (KG)
38791	2"	50	203	165	125	4-19	11.0
38968	2½"	65	216	185	145	4-19	12.2
38969	3"	80	241	200	160	8-19	15.0
38970	4"	100	292	220	180	8-19	20.0
36371	5"	125	292	250	210	8-19	25.7
36372	6"	150	356	285	240	8-23	39.7
38792	8"	200	495	340	295	8-23	74.0
38793	10"	250	622	405	355	12-28	102.3
38794	12"	300	698	460	410	12-28	149.2

# Wafer Dual Plate Check Valve CIV 08



## Technical Data

- Size: DN50 - DN300 (2" - 12")
- Max Pressure: PN16
- Temperature Range: -20°C - 135°C
- Suitable for: Water

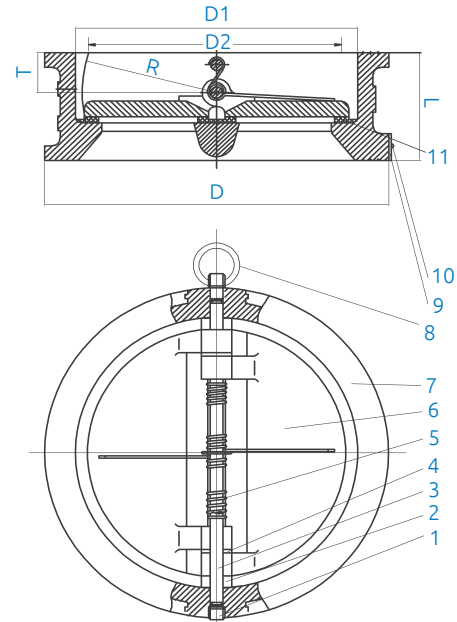

## Features and Benefits

- Self-acting pivoting check valve of the double disc
- The corrosion resisting springs are designed to quickly close the valve to prevent undesirable pressure surges
- It automatically opens when the flow starts
- The elastomer seats is vulcanised and bonded to the body casting.

## Applicable Standards

- Design standards: GB/T12236
- End standard: suitable for EN1092-2 PN16
- Face to face standard: ISO 5752
- Testing standard: ISO 5208

## Material Specifications

NO	NAME	MATERIAL	QUANTITY
1	Plug	SS304	4
2	Washer	PTFE	2
3	Pin	SS410	2
4	Washer	PTFE	3
5	Spring	SS304	2
6	Plate	CF8M	2
7	Body	CI	1
8	Eyeblot	SS304	1
9	Trademark	Stainless Steel	1
10	Plate Rivet	Stainless Steel	2
11	Seat	EPDM	1

## Dimensions

STOCK NO.	SIZE	D	D1	D2	L	R	T
38923	DN50	106	65	45.6	43	29.7	18.5
38924	DN65	126	78	60.1	46	36.1	21.5
38925	DN80	141	94	66.3	64	43.4	28
38926	DN100	161	117	97.2	64	55.6	27
38927	DN125	191	145	122.4	70	68.1	30
38928	DN150	217	170	144.4	76	78.6	31
38855	DN200	272	222	198.0	89	104.4	33
38862	DN250	327	265	233.7	114	128	50.5
38883	DN300	380	310	283.2	114	148	43

# Flange Mount Fully Lugged Ductile Iron Butterfly Valve

## CIV 02



### Technical Data

- Lugged & tapped butterfly valve
- Lever operation
- Body: ductile iron
- Disc: CF8M
- Stem: SS410
- Seat: WRAS EPDM
- Size: DN65 - DN300 (2½" to 10")
- Nominal Pressure: PN 16
- Temp. Range: -10°C to 120°C
- WRAS Temp. Range: -10°C to 85°C
- Suitable For: Water and neutral liquids



### Features and Benefits

- Lug pattern design, safety for high pressure application
- O-ring stem sealing, low torque operation
- Streamlined stainless steel disc, lower water head lost
- ISO top flange as standard, easy to suit actuators
- Bi-directional shut-off seat
- Eccentric pin on the stem, protects the structure of the stem, providing safety and strength
- Both gear operated and lever operated are available

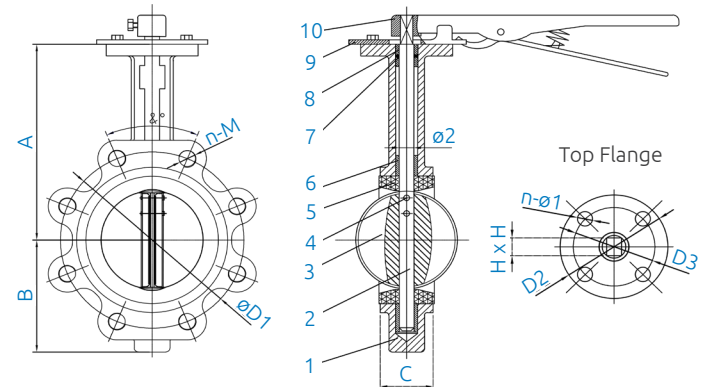

### Applicable Standards

- Design standard: EN 593, BS 5155
- Connection standard: Suitable for EN1092-2
- Face to face standard: EN 558-1 BS 5155
- Top flange standard: ISO5211/1
- Testing standard: EN 12266-1

### Material Specifications

NO	NAME	MATERIAL
1	Body	Ductile Iron JS1040
2	Disc	Stainless Steel CF8M
3	Stem	Stainless Steel SS410
4	Seat	EPDM
5	O-ring	EPDM

### Dimensions

STOCK NO.	SIZE	A	B	C	D	ø2	ISO5211	K	E	n-ø	HxH	L	OD	ID	WEIGHT (kg)	TORQUE
38942	DN50	140	80	43	52.9	12.6	F07	90	70	4 - 10	11 x 11	14	165	125	4.5	12
38943	DN65	150	89	46	64.5	12.6	F07	90	70	4 - 10	11 x 11	14	185	145	4.8	20
38944	DN80	158	95	46	78.8	12.6	F07	90	70	4 - 10	11 x 11	14	200	160	5.6	30
38945	DN100	176	114	52	104.0	15.8	F07	90	70	4 - 10	11 x 11	14	220	180	7.7	50
38946	DN125	190	127	56	123.3	18.9	F07	90	70	4 - 10	14 x 14	17	250	210	9.6	77
38947	DN150	212	139	56	155.6	18.9	F07	90	70	4 - 10	14 x 14	17	285	240	10.7	121
38948	DN200	235	174	60	202.5	22.1	F10	125	102	4 - 12	17 x 17	22	340	295	17.5	242
38949	DN250	265	203	68	250.5	28.5	F10	125	102	4 - 12	22 x 22	22	405	355	28.3	352
38841	DN300	305	242	78	301.6	31.6	F10	125	102	4 - 12	22 x 22	22	460	410	41.0	490

# Gear Lugged Butterfly Valve

## CIV 02 G



### Features and Benefits

- Lug pattern design, safety for high pressure application
- O-ring stem sealing, low torque operation
- Streamlined stainless steel disc, lower water head lost
- ISO top flange as standard, easy to suit actuators
- Bi-directional shut-off seat
- Eccentric pin on the stem, protects the structure of the stem, providing safety and strength
- Both gear operated and lever operated are available

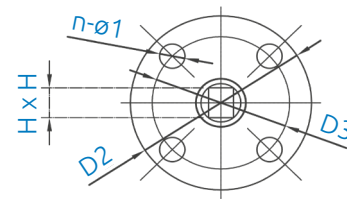
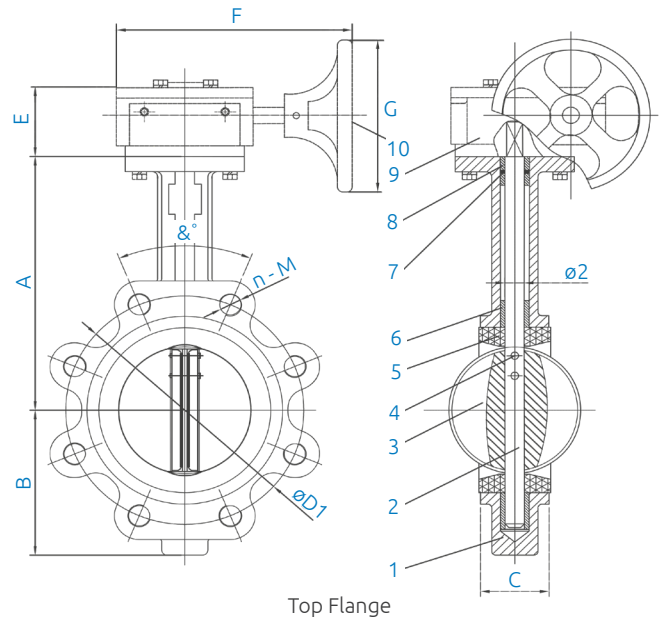

### Applicable Standards

- Design standard: EN 593, BS 5155
- Connection standard: Suitable for EN1092-2
- Face to face standard: EN 558-1, BS 5155
- Top flange standard: ISO5211/1
- Testing standard: EN 12266-1

### Technical Data

- Lugged & tapped butterfly valve
- Gear operation
- Size: 6" to 12"
- Nominal Pressure: PN16
- Operating Temperature Range: -10°C to +120°C
- Suitable for : water and neutral liquids

STOCK NO.	REDUCTION RATIO	OUTPUT TORQUE	INPUT TORQUE
38750	24:1	150NM	50NM
38751	30:1	500NM	70NM
38752	30:1	500NM	70NM
38753	50:1	1000NM	90NM

### Dimensions

STOCK NO.	SIZE	A	B	C	Ø2	D2	D3	E	F	G	n-Ø1	ØD1	n-M	&°	H x H	WEIGHT (KG)
38750	6"	212	139	56	18.92	90	70	71	195	147	4-10	240	8-M20	45	14x14	12.93
38751	8"	236	174	60	22.10	125	102	82	285	292	4-12	295	12-M20	30	17x17	21.50
38752	10"	265	203	68	28.45	125	102	82	285	292	4-12	355	12-M24	30	22x22	31.22
38753	12"	305	242	78	31.60	125	102	82	285	292	4-12	410	12-M24	30	22x22	47.00

### Material Specifications

NO	NAME	MATERIAL	QTY
1	Body	DI	1
2	Shaft	SS410	1
3	Disc	CF8M	1
4	Taper Pin	SS316	2
5	Seat Liner	EPDM	1
6	Long Bushing	FRP	2
7	O-Ring	NBR	1
8	Short Bushing	FRP	2
9	Worm Gear	DI	1
10	Hand Wheel	CI	1



# Wafer Ductile Iron Butterfly Valve

## CIV 01



### Features and Benefits

- Wafer pattern design, for quick installation
- Wider EPDM seat design, replaceable, suits different type of flanges
- Streamlined stainless steel disc, lower water head lost
- ISO top flange as standard, easy to suit actuators
- Bi-directional shut-off seat
- Eccentric pin on the stem, protects the structure of the stem, providing safety and strength
- Lever operation DN50 - DN150
- Gearbox operation DN200 - DN300

### Applicable Standards

- Design standard: EN 593, BS 5155
- Connection standard: Suitable for EN1092-2
- Face to face standard: EN 558-1 BS 5158
- Top flange standard: ISO5211/1
- Testing standard: EN 12266-1

### Dimensions

STOCK NO.	SIZE	A	B	C	D	ø2	ISO5211	K	E	4-ØD	HxH	L	OD	ID	WEIGHT (kg)	TORQUE
38935	DN50	140	80	43	52.9	12.6	F07	90	70	4 - 10	11 x 11	14	165	125	3.3	12
38936	DN65	150	89	46	64.5	12.6	F07	90	70	4 - 10	11 x 11	14	185	145	3.8	20
38937	DN80	158	95	46	78.8	12.6	F07	90	70	4 - 10	11 x 11	14	200	160	4.0	30
38938	DN100	176	114	52	104	15.8	F07	90	70	4 - 10	11 x 11	14	220	180	5.2	50
38939	DN125	190	127	56	123.3	18.9	F07	90	70	4 - 10	14 x 14	17	250	210	7.1	77
38940	DN150	212	139	56	155.6	18.9	F07	90	70	4 - 10	14 x 14	17	285	240	8.0	121
38941	DN200	235	174	60	202.5	22.1	F10	125	102	4 - 12	17 x 17	22	340	295	14.0	242
38820	DN250	265	203	68	250.5	28.5	F10	125	102	4 - 12	22 x 22	22	405	355	20.0	352
38827	DN300	305	242	78	301.6	31.6	F10	125	102	4 - 12	22 x 22	22	460	410	29.5	490

### Technical Data

- Water butterfly valve
- Lever operation
- Body: ductile iron
- Disc: CF8M
- Stem: SS410
- Seat: WRAS EPDM
- Size: DN300, DN150 (2 1/2" to 10")
- Nominal Pressure: PN 16
- Temp. Range: -20 to +100°C
- Suitable For: Water and neutral liquids

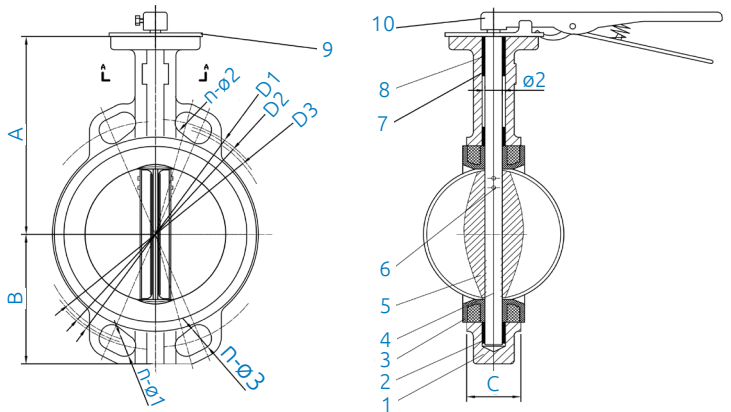

Top Flange

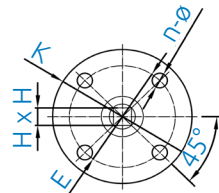

### Material Specifications

NO	NAME	MATERIAL
1	Body	Ductile Iron JS1040
2	Disc	Stainless Steel CF8M
3	Stem	Stainless Steel SS410
4	Seat	EPDM

# Flange Mount Fully Lugged Ductile Iron Butterfly Valve (Gas)

## CIV 07



### Technical Data

- Lugged & tapped butterfly valve
- Lever operation
- Body: ductile iron
- Size: DN50 - DN300 (2" to 12")
- Nominal Pressure: PN 16
- Temp. Range: 0 to +80°C
- Suitable For: Gas

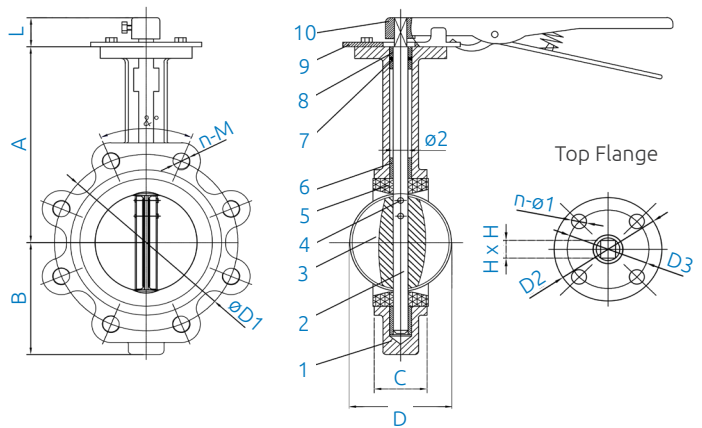

### Features and Benefits

- Lug pattern design, safety for high pressure application
- O-ring stem sealing, low torque operation
- Streamlined stainless steel disc, low Head loss
- ISO top flange as standard, easy to suit actuators
- Bi-directional shut-off seat
- Eccentric pin on the stem, protects the structure of the stem
- Both gear and lever operated are available

### Applicable Standards

- Design standard: EN 593, BS 5155
- Connection standard: Suitable for EN1092-2
- Face to face standard: EN 558-1 BS 5155
- Top flange standard: ISO5211/1
- Testing standard: EN 12266-1

### Dimensions

STOCK NO.	SIZE	A	B	C	D	ø2	ISO5211	D2	D3	n-ø1	HxH	L	n-M	D1	WEIGHT (kg)	TORQUE
39004	DN50	140	80	43	52.9	12.6	F07	90	70	4 - 10	11 x 11	14	4 - M16	125	4.5	12
38950	DN65	150	89	46	64.5	12.6	F07	90	70	4 - 10	11 x 11	14	4 - M16	145	4.8	20
38951	DN80	158	95	46	78.8	12.6	F07	90	70	4 - 10	11 x 11	14	8 - M16	160	5.6	30
38952	DN100	176	114	52	104.0	15.8	F07	90	70	4 - 10	11 x 11	14	8 - M16	180	7.7	50
38953	DN125	190	127	56	123.3	18.9	F07	90	70	4 - 10	14 x 14	17	8 - M16	210	9.6	77
38954	DN150	212	139	56	155.6	18.9	F07	90	70	4 - 10	14 x 14	17	8 - M20	240	10.7	121
38955	DN200	235	174	60	202.5	22.1	F10	125	102	4 - 12	17 x 17	22	12 - M24	295	17.5	242
38869	DN250	265	203	68	250.5	28.5	F10	125	102	4 - 12	22 x 22	22	12 - M24	355	28.3	352
38876	DN300	305	242	78	301.6	31.6	F10	125	102	4 - 12	22 x 22	22	12 - M24	410	41.0	490

### Material Specifications

NO	NAME	MATERIAL
1	Body	Ductile Iron JS1040
2	Stem	Stainless Steel SS410
3	Disc	Stainless Steel CF8M
4	Taper Pin	Stainless Steel SS316
5	Liner (Seat)	NBR
6	Long Bushing	FRP
7	O-Ring	NBR
8	Short Bushing	FRP
9	Indicator	Carbon Steel
10	Lever	Malleable Iron

# Gear Lugged Butterfly Valve - Gas

## CIV 07 G



### Features and Benefits

- Lug pattern design, safety for high pressure application
- O-ring stem sealing, low torque operation
- Streamlined stainless steel disc, lower water head lost
- ISO top flange as standard, easy to suit actuators
- Bi-directional shut-off seat
- Eccentric pin on the stem, protects the structure of the stem, providing safety and strength
- Both gear operated and lever operated are available

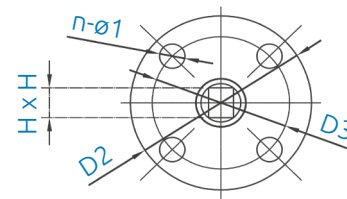
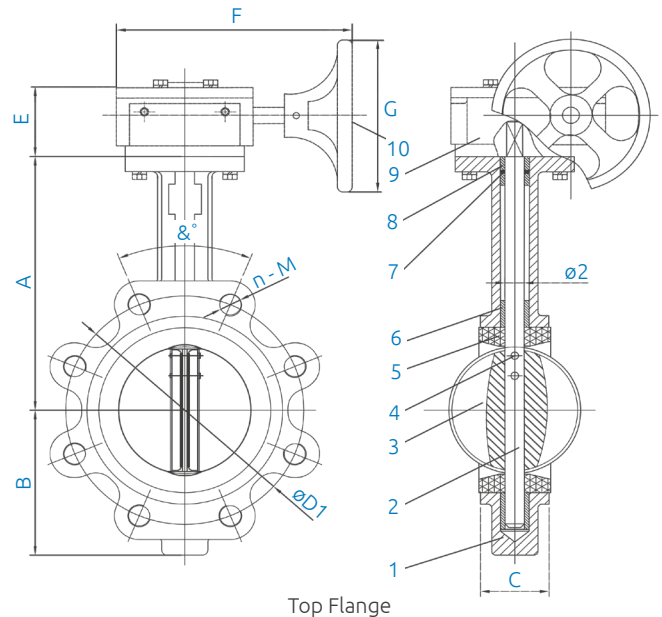

### Applicable Standards

- Design standard: EN 593, BS 5155
- Connection standard: Suitable for EN1092-2
- Face to face standard: EN 558-1, BS 5155
- Top flange standard: ISO5211/1
- Testing standard: EN 12266-1

### Technical Data

- Lugged & tapped butterfly valve
- Gear operation
- Size: 6" to 12"
- Nominal Pressure: PN16
- Operating Temperature Range: 0°C to +80°C
- Suitable for : Gas

STOCK NO.	REDUCTION RATIO	OUTPUT TORQUE	INPUT TORQUE
38740	24:1	150NM	50NM
38741	30:1	500NM	70NM
38742	30:1	500NM	70NM
38743	50:1	1000NM	90NM

### Dimensions

STOCK NO.	SIZE	A	B	C	Ø2	D2	D3	E	F	G	n-Ø1	ØD1	n-M	&°	H x H	WEIGHT (KG)
38740	6"	212	139	56	18.92	90	70	71	195	147	4-10	240	8-M20	45	14x14	12.93
38741	8"	236	174	60	22.10	125	102	82	285	292	4-12	295	12-M20	30	17x17	21.50
38742	10"	265	203	68	28.45	125	102	82	285	292	4-12	355	12-M24	30	22x22	31.22
38743	12"	305	242	78	31.60	125	102	82	285	292	4-12	410	12-M24	30	22x22	47.00

### Material Specifications

NO	NAME	MATERIAL	QTY
1	Body	DI	1
2	Shaft	SS410	1
3	Disc	CF8M	1
4	Taper Pin	SS316	2
5	Seat Liner	NBR	1
6	Long Bushing	FRP	2
7	O-Ring	NBR	1
8	Short Bushing	FRP	2
9	Worm Gear	DI	1
10	Hand Wheel	CI	1

# Brass Y Strainer Compression STR 03



## Features and Benefits

- Brass Body
- Stainless Steel Mesh Filter
- Suitable for both domestic & commercial applications

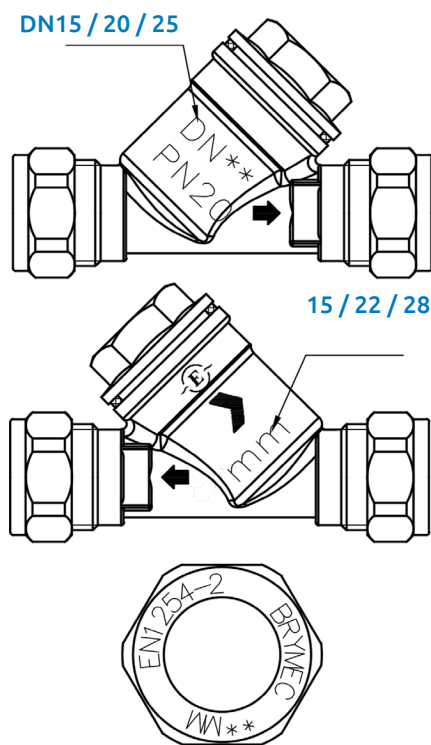

## Technical Data

- Fields of applications: water
- Maximum working pressure: PN20
- Maximum working temperature: 90°C

## Applicable Standards

- Compression connections comply with BS EN 1254-2

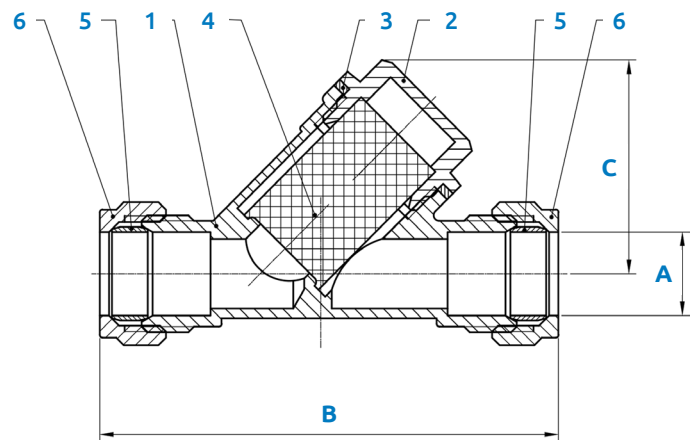

## Material Specifications

NO	NAME	MATERIAL	QUANTITY
1	Body	HPb59-T	1
2	Bonnet	HPb59-T	1
3	Washer	PTFE	1
4	Filter	Stainless Steel	1
5	Olive	T2	2
6	Compression nut	HPb59-T	2

## Versions and Products Codes

STOCK NO	DN	A (mm)	B	C
36230	15	15	54	40.5
36231	22	22	64	48.7
36232	28	28	71	52.5

# Brass Y Strainer

## STR 02



### Features and Benefits

- Brass Body
- Stainless Steel Mesh
- BSP Fx F Thread

DN15 - DN100

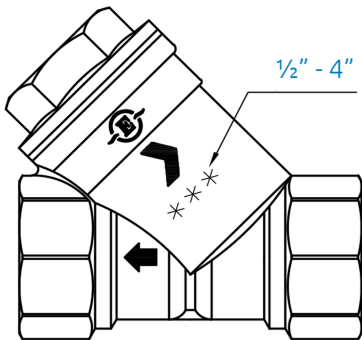
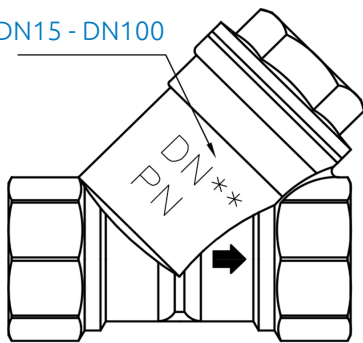

### Technical Data

- Fields of applications: water
- 1/2" - 2" Maximum working pressure: PN20
- 2 1/2" - 4" Maximum working pressure: PN16
- Maximum working temperature: 90°C

### Applicable Standards

- BSP parallel ISO 228/1 connections

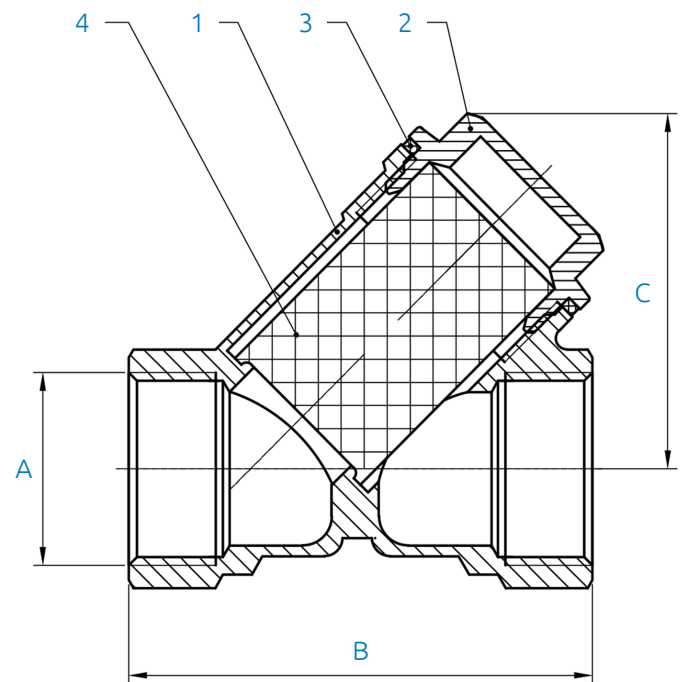

### Material Specifications

NO	NAME	MATERIAL	QUANTITY
1	Body	HPb59-T	1
2	Bonnet	HPb59-T	1
3	Washer	PTFE	1
4	Filter net	Stainless Steel	1

### Versions and Products Codes

STOCK NO	DN	A	B (mm)	C
36233	1/2"	1/2"	54	40.5
36234	3/4"	3/4"	64	48.7
36235	1"	1"	71	52.5
36236	1 1/4"	1 1/4"	91	71
36237	1 1/2"	1 1/2"	100	77
36238	2"	2"	122	94
36239	2 1/2"	2 1/2"	176	122
36240	3"	3"	201	135.5
36241	4"	4"	250	168

# Bronze Y Strainer

## STR 01



### Technical Data

- Max. Pressure: 20 Bar
- Operating Temp. Range: -10 to +180°C

### Applicable Standards

- Screwed BSP Taper (ISO 7/1)



### Features and Benefits

- Bronze body
- Stainless steel mesh
- Screwed cap

### Pressure / Temperature

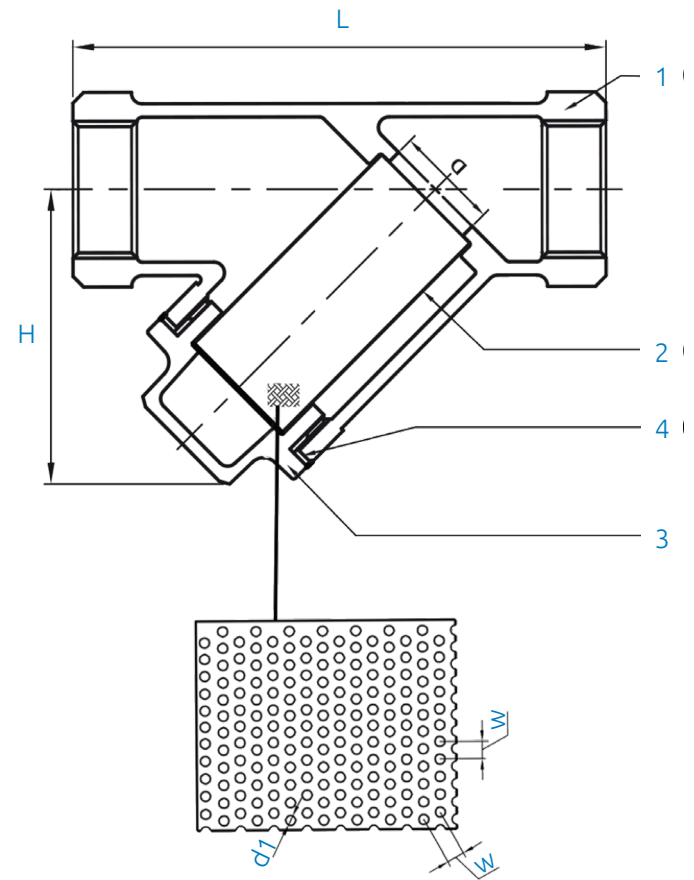
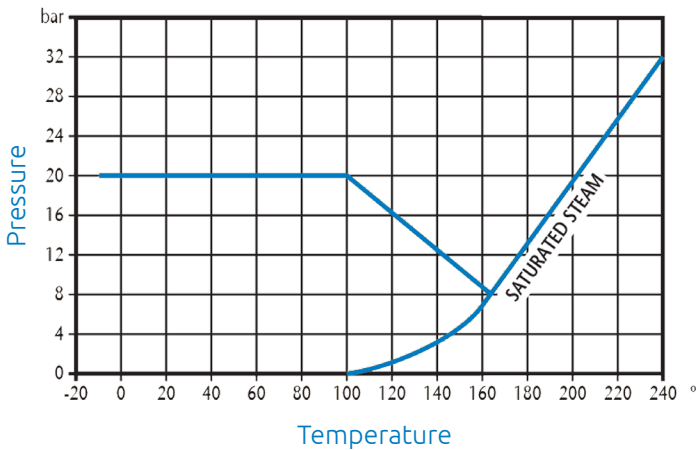

### Versions and Products Codes

STOCK NO	DN	L	H	D	d1	W	Kgs
38884	1/2"	80	48.5	14	0.84	1.27	0.31
38885	3/4"	100	58	19	0.84	1.27	0.49
38886	1"	115	70	25	0.84	1.27	0.71
38887	1 1/4"	135	80	31.8	0.84	1.27	0.99
38888	1 1/2"	160	93	38.1	0.84	1.27	1.46
38889	2"	190	112	50	0.84	1.27	2.44

### Material Specifications

NO	NAME	MATERIAL	QUANTITY
1	Body	Bronze	1
2	Screen	Stainless Steel	1
3	Cap	Bronze	1
4	Gasket	Non Asbestos	1

# Y Strainer Valve

## CIV 05



### Technical Data

- Size: DN50 - DN400 (2" - 16")
- Nominal pressure: PN 16
- Temperature range: 0°C - 80°C
- Suitable for: Water

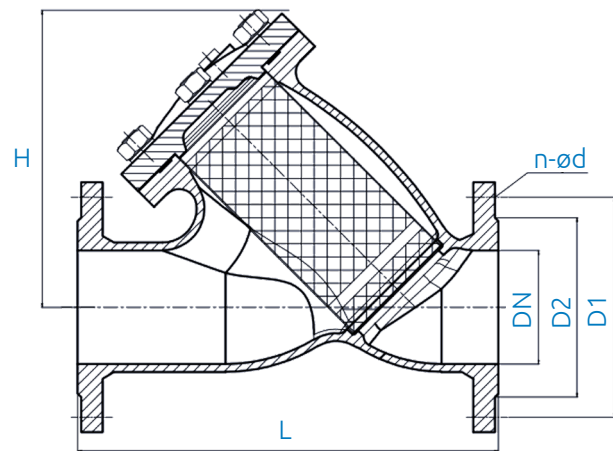

### Features and Benefits

- Body and cover are in ductile iron for long product life cycle
- Screen is punched stainless steel plate
- Screen is supported by a leg for DN150 and above, this device protects the screen from potential damage
- Large filter area: lower pressure drop
- Electrostatically applied akzo Nobel epoxy powder internally and externally

### Applicable Standards

- Connection standard: BS EN 1092-2
- Pressure test standard: BS EN 12266-2003
- Face to face standard: BS EN558-1 Series 1

### Material Certification

- Epoxy powder WRAS Certification NO: 1112500
- Rubber parts WRC-NSF test reports NO: MAT/LAB 550C/1
- Sealing parts test reports NO: CE/2012/20910

### Material Specifications

NO	NAME	MATERIAL
1	Body	Ductile Iron EN JS1040
2	Cover	Ductile Iron EN JS1040
3	Screen	304 Stainless Steel BS970
4	Gasket	Rubber EPDM

### Y Strainer Dimensions

STOCK NO.	SIZE	DN	L	H	D2	D1	n-ød	Weight (KG)
38796	2"	50	230	140	99	125	4 - 19	10.40
38973	2 ½"	65	290	161	118	145	4 - 19	13.80
38974	3"	80	310	181	132	160	8 - 19	16.60
38975	4"	100	350	210	156	180	8 - 19	23.20
38976	5"	125	400	250	184	210	8 - 19	32.50
38977	6"	150	480	308	211	240	8 - 23	43.90
38797	8"	200	600	406	226	295	12 - 23	66.10
38798	10"	250	730	476	319	355	12 - 28	113.50
38799	12"	300	850	543	370	410	12 - 28	151.50

# Y Strainer Valve

## CIV 05

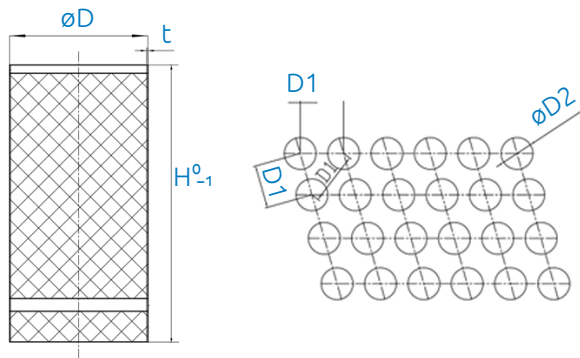

### Mesh Data

DN	H	$\varnothing D$	t	D1	$\varnothing D2$	Filter Area	Kv (m <sup>3</sup> /h)	Rate
50	109	60	0.8	4	$\varnothing 2$	333%	66.7	2.20
65	139	75	0.8	4	$\varnothing 2$	307%	89.0	3.50
80	159	90	0.8	4	$\varnothing 2$	284%	127.0	4.00
100	189	110	0.8	4	$\varnothing 2$	265%	200.0	3.90
125	223	135	0.8	5	$\varnothing 3$	245%	364.0	2.60
150	262	160	0.8	5	$\varnothing 3$	237%	494.0	3.30
200	330	210	1.2	7	$\varnothing 5$	221%	937.0	2.90
250	401	260	1.2	7	$\varnothing 5$	213%	1137.0	4.80
300	461	310	1.2	7	$\varnothing 5$	207%	1844.0	3.80



# Compression Wheelhead Brass Gate Valve



## Features and Benefits

- Compression ends
- Brass body & Gate (wedge)

## Applicable Standards

- Valves are manufactured to: BS5154
- Compression connections comply with: EN1254-2
- WRAS approved up to 28mm

## Product Codes and Dimensions

STOCK NO	WRAS	A (mm)	B	C	D
30813	YES	15	61	70	13
30814	YES	22	71	75	19
30815	YES	28	76	89	24
30816	NO	35	92	119	32
30817	NO	42	101	127	38
30818	NO	54	123	157	50

## Technical Data

- Suitable for: Water
- Max. Working Pressure: PN16
- Max. Working Temp: 90°C

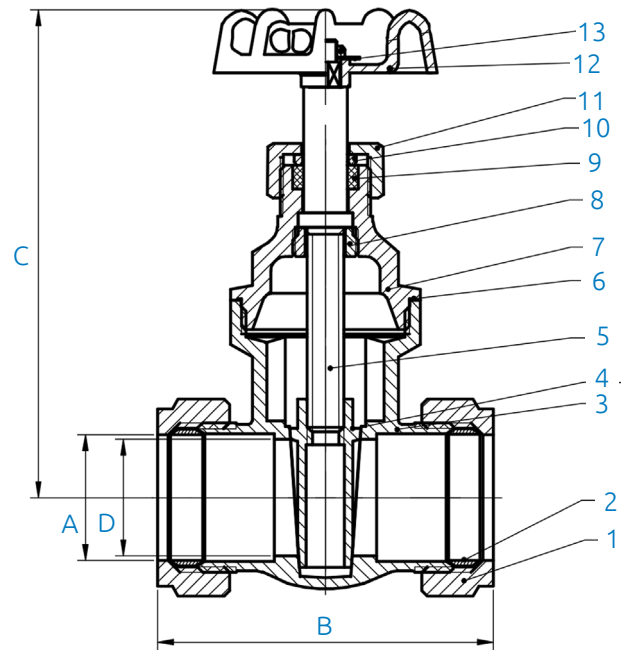

## Material Specifications

NO	NAME	MATERIAL	QUANTITY
1	Comperssion nut	HPb59- T	2
2	Olive	T2	2
3	Body	HPb59- T	1
4	Gate	HPb59- T	1
5	Stem	HPb59- T	1
6	Sealing washer	PTFE	1
7	Bonnet	HPb59- T	1
8	Lock ring	HPb59- T	1
9	Packing	PTFE	1
10	Lock nut	HPb59- T	1
11	Handle	Cast iron	1
12	Nameplate	AL	1
13	Nut	Q235	1

# Gate Valve with Lockshield - Compression



## Features and Benefits

- Compression ends
- Brass body & Gate (wedge)

## Applicable Standards

- Valves are manufactured to: BS5154
- Compression connections comply with: EN1254-2
- WRAS approved

## Product Codes and Dimensions

STOCK NO	A (mm)	B (mm)	C (mm)	D (mm)
30700	15	54	57	13
30707	22	65	80	15
30299	28	72	91	19
30793	35	90	112	32

## Technical Data

- Suitable for: Water
- Max. Working Pressure: PN16
- Max. Working Temp: 90°C

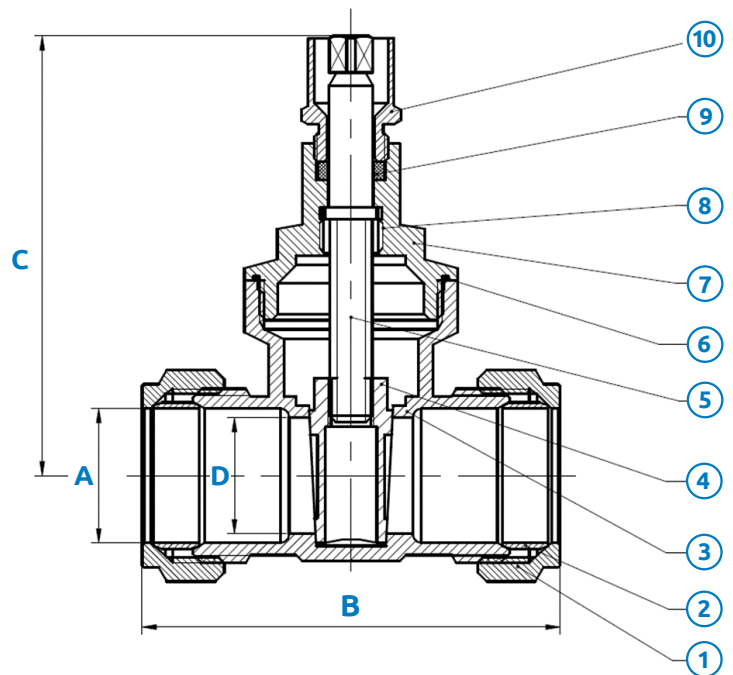

## Material Specifications

NO	NAME	MATERIAL	QUANTITY
1	Comperssion nut	HPb59- T	2
2	Olive	T2	2
3	Body	HPb59- T	1
4	Gate	HPb59- T	1
5	Stem	HPb59- T	1
6	Sealing washer	PTFE	1
7	Bonnet	HPb59- T	1
8	Lock ring	HPb59- T	1
9	Packing	PTFE	1
10	Lock nut	HPb59- T	1

# Wheelhead Bronze Gate Valve



## Features and Benefits

- Screwed BSP Taper (ISO 7/1)
- Bronze Body and Disc
- Screwed Bonnet

## Pressure - Temperature Diagram

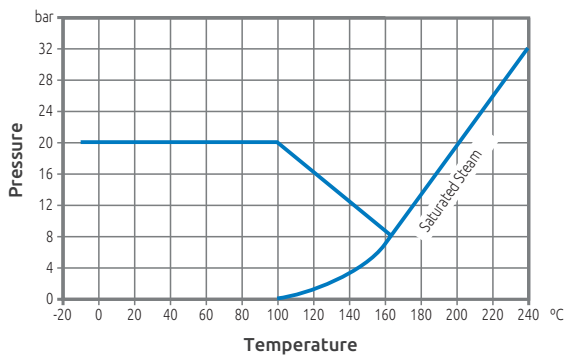

## Dimensions

STOCK NO.	DN	L	H	D	WEIGHT (kg)
38856	15	47.5	78.0	53.0	0.33
38857	20	51.5	94.0	63.5	0.48
38858	25	58.6	109.0	68.5	0.65
38859	32	63.0	120.0	80.0	0.93
38860	40	66.5	142.0	90.0	1.24
38861	50	73.5	163.0	103.0	1.92

## Technical Data

- Maximum working pressure: PN20
- Working temperature range: -10°C to +232°C

## Applicable Standards

- PN20 Rated
- BS 5154 (BS EN 12288)
- WRAS Approved

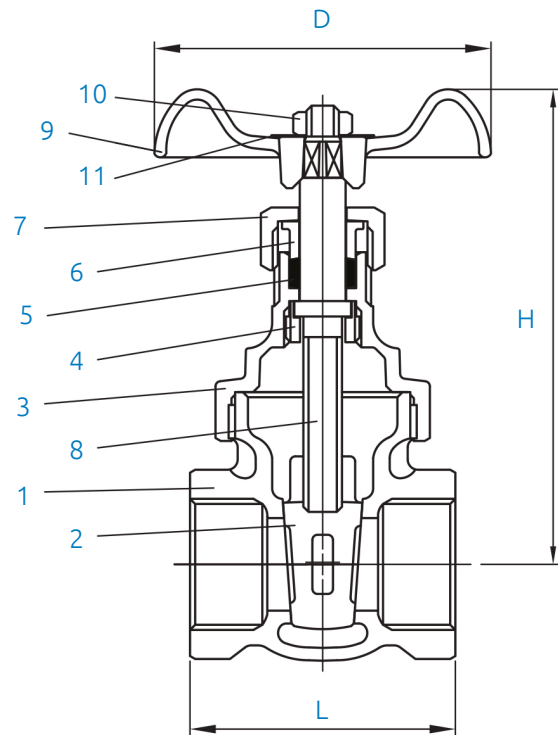

## Material Specifications

NO	COMPONENT	MATERIAL
1	Body	Bronze ASTM B62 C83600
2	Disc	Bronze ASTM B62 C83600
3	Bonnet	Bronze ASTM B62 C83600
4	Lock nut	Bronze ASTM B16 C3600
5	Stem packing	PTFE
6	Gland	Bronze ASTM B16 C3600
7	Packing nut	Bronze ASTM B16 C3600
8	Stem	Bronze ASTM B16 C3600
9	Hand wheel	Cast Iron ASTM A126 Class B
10	Wheel nut	Steel Zn Plated ASTM A563
11	Name plate	Aluminium ASTM B92 1100

# Lockshield Bronze Gate Valve

## GVA 02



### Features and Benefits

- Screwed BSP Taper (ISO 7/1)
- Bronze Body and Disc
- Screwed Bonnet
- Lock shield

### Pressure - Temperature Diagram

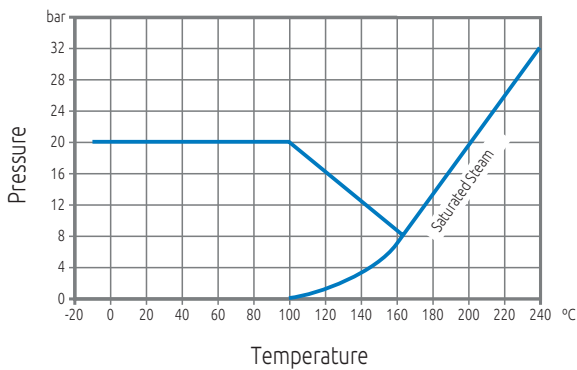

### Dimensions

STOCK NO.	DN	L	H	S	WEIGHT (kg)
38863	15	47.5	70.0	6.3	0.3
38864	20	51.5	80.5	6.3	0.4
38865	25	58.6	94.0	6.3	0.6
38866	32	63.0	110.5	8.0	0.8
38867	40	66.5	123.5	8.0	1.1
38868	50	73.5	146.5	9.5	1.62

### Technical Data

- Maximum working pressure: PN20
- Working temperature range: -10°C to +180°C

### Applicable Standards

- PN20 Rated
- BS 5154 (BS EN 12288)
- WRAS Approved

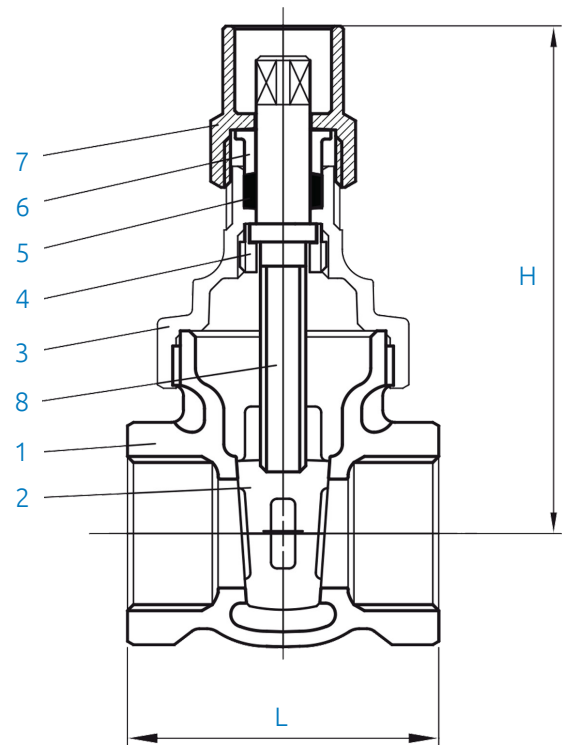

### Material Specifications

NO	COMPONENT	MATERIAL
1	Body	Bronze
2	Disc	Bronze
3	Bonnet	Bronze
4	Lock nut	Brass
5	Stem packing	PTFE
6	Gland	Brass
7	Packing nut	Brass
8	Stem	Brass

# Wheelhead Brass Gate Valve



## Technical Data

- Suitable for: Water & Oil Systems
- Max. Working Pressure: PN20
- Max. Working Temp: 90°C

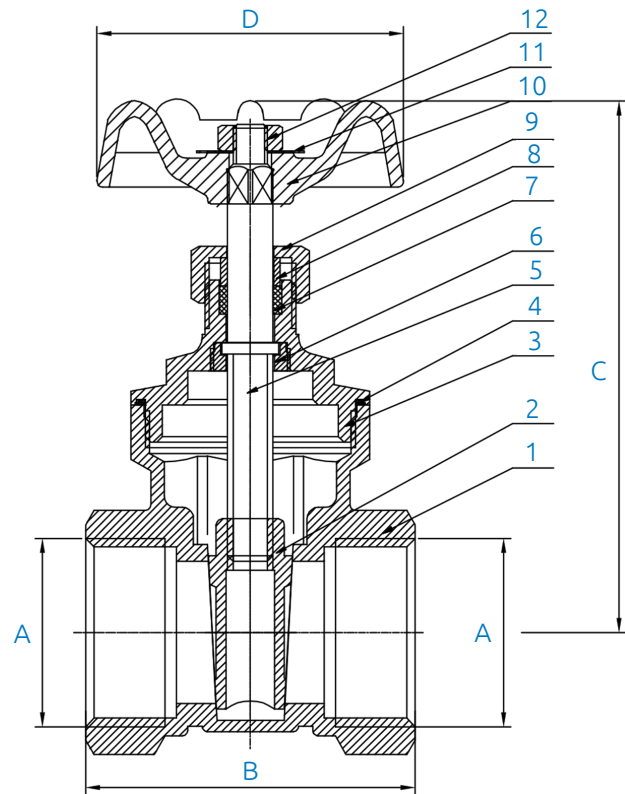

## Features and Benefits

- Female threaded ends
- Brass body & Gate (wedge)
- PTFE seat & packing

## Applicable Standards

- Valves are manufactured to: BS5154 (BS EN 12288)
- BSP Parallel ISO 228/1 connections

## Product Codes & Dimensions

STOCK NO	DN	A	B	C	D	Kgs
30777	½"	G1/2	47	78	55	0.21
30778	¾"	G3/4	52	82	55	0.25
30779	1"	G1	58	90	59	0.35
30782	1 ¼"	G1 ¼	74	110	59	0.71
30783	1 ½"	G1 ½	81	127	71	0.92
30784	2"	G2	88	150	77	1.42
30785	2 ½"	G2 ½	94	163.5	100	2.55
30786	3"	G3	103	190	110	3.22
30789	4"	G4	119.5	235	130	5.76

## Material Specifications

NO	NAME	MATERIAL	QUANTITY
1	Body	HPb59- T	1
2	Gate	HPb59- T	1
3	Bonnet	HPb59- T	1
4	Sealing Washer	PTFE	1
5	Stem	HPb59- T	1
6	Lock Ring	HPb59- T	1
7	Packing	PTFE	1
8	Lock Nut	HPb59- T	1
9	Lock Ring	HPb59- T	1
10	Handle	Cast Iron	1
11	Nameplate	AL	1
12	Nut	45#	1

# Flange Ductile Iron Gate Valve

## CIV 03



### Features and Benefits

- Ductile iron body and bonnet with high strength and impact resistance
- Rubber encapsulated DI wedge to ensure drop tight sealing
- Rubber bonnet gasket for longevity and protection of bonnet bolts
- Stainless steel stem with high strength and corrosion resistance
- Back sealing facility to allow for replacement of seals under full operating pressure
- Straight through full bore to avoid debris traps
- Isolated fasteners for corrosion protection
- Wiper ring to prevent impurities from entering the stem sealing system
- Anti friction thrust washer for low operating torques
- Integral cast foot for safe and easy storage
- Full diameter waterway hand wheel, square cap operation

### Applicable Standards

- Design standard: BS 5163
- Face to face standard: BS 5163
- Flange standard: BS4504 PN 10/16
- Testing standard EN 12266-1

### Technical Data

- Non-rising stem gate valve
- Handwheel operated
- Body: ductile iron
- Gate: ductile iron & WRAS EPDM
- Stem: SS410
- BS5163
- Size: DN65 - 300
- Nominal Pressure: PN 16
- Temp. Range: -10°C to +90°C
- Suitable For: Water and neutral liquids

### Technical Data

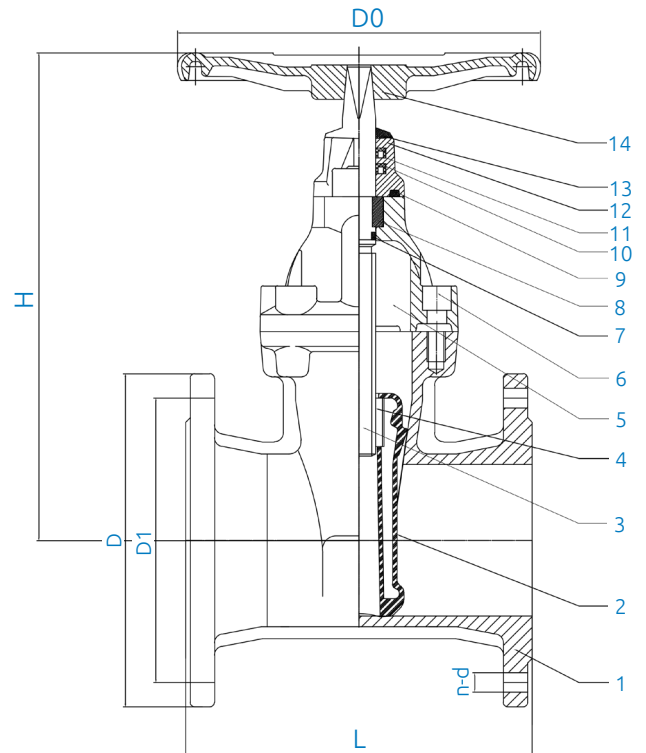

### Material Specifications

NO	NAME	MATERIAL	SPECIFICATION
1	Body	Ductile Iron	GGG50
2	Wedge	GGG50 + NBR GGG50 + EPDM	Ductile Iron + NBR Ductile Iron + EPDM
3	Stem	Stainless Steel	SS410
4	Wedge Nu	Brass	Brass
5	Bonnet	Ductile Iron	GGG50
6	Bolt		
7	O Ring	EPDM / NBR	EPDM / NBR
8	Stem Collar	Brass	Brass
9	Bonnet Gasket	EPDM / NBR	EPDM / NBR
10	V Ring	EPDM / NBR	EPDM / NBR
11	V Ring	EPDM / NBR	EPDM / NBR
12	Top Cap	Ductile Iron	GGG50
13	Dust Shield	EPDM / NBR	EPDM / NBR
14	Hand Wheel	Ductile Iron	GGG50

# Flange Ductile Iron Gate Valve cont.



## Dimensions

STOCK NO.	SIZE (mm)	L	D0	H	D	D1	D2	n-ø	F	B	HAND WHEEL WEIGHT (kg)	TORQUE
38813	50	178	160	220	165	125	99	4 - 19	3	19	10.5	60
38956	65	190	180	235	185	145	118	4 - 19	3	19	12.5	75
38957	80	203	200	280	200	160	132	8 - 19	3	19	16.0	75
38958	100	229	200	320	220	180	156	8 - 19	3	19	21.0	100
38959	125	254	250	360	250	210	184	8 - 19	3	19	29.0	125
38960	150	267	250	400	285	240	211	8 - 23	3	23	35.0	150
38961	200	292	322	510	340	295	266	12 - 23	3	23	57.0	200
38967	250	330	353	600	405	355	319	12 - 28	3	28	92.0	250
38834	300	356	353	625	460	410	370	12 - 28	4	28	129.0	300

# Push-fit / Crimp Spigot Tail Drain-Off Cock

## DOC 03



### Features & Benefits

- For hot and cold water systems
- Push-fit/crimp for ease of connections
- Square drive drain valve operation

### Versions & Product Codes

STOCK NO.	SIZE	DESCRIPTION
30298	15mm	Long Spigot Drain Off Cock
31150	15mm	Solder Drain Off Cock

### Technical Data

- Fields of Applications: Water
- Max. Working Pressure: PN10
- Operating Temp. Range: 0 to +70°C
- Max. working temperature: Up to 70°C with occasional excursions  
Up to 90°C max for period of 1 hour

### Applicable Standards

- Valves are manufactured to: BS2879-2
- Capillary end complies with: EN1254-1
- WRAS Approved

### Material Specifications

NO	NAME	MATERIAL	QUANTITY
1	Body	HPb59-T	1
2	Washer	NBR	1
3	Stem	HPb59-T	1
4	Lock nut	HPb59-T	1
5	O-ring	NBR	1

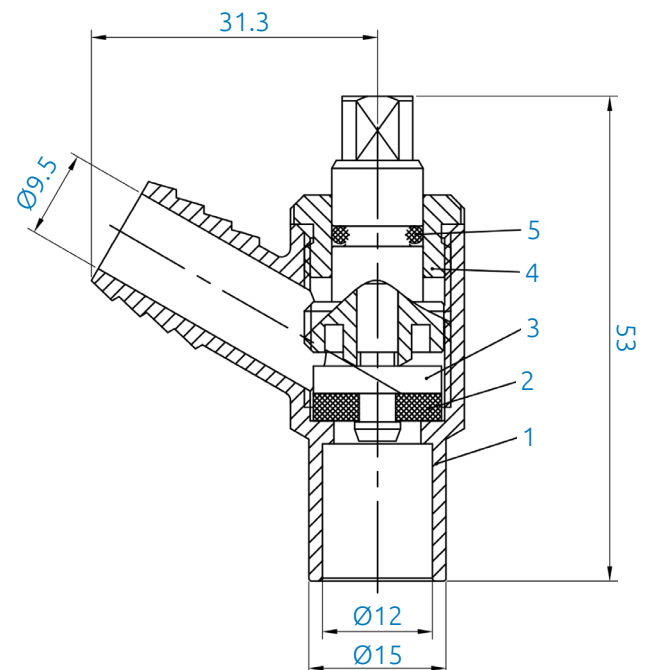
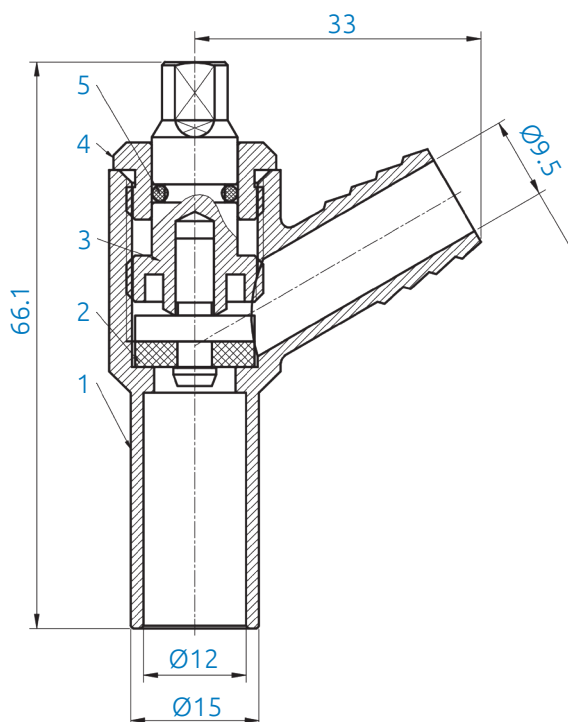



# Male BSP Tail 1/2"

## Drain-Off Cock

### DOC 04



### Features & Benefits

- For hot and cold water systems
- 1/2" BSP Male connections
- Square drive drain valve operation

### Versions & Product Codes

STOCK NO.	SIZE
31151	1/2"

### Material Specifications

NO	NAME	MATERIAL	QUANTITY
1	Body	HPb59-T	1
2	Washer	NBR	1
3	Stem	HPb59-T	1
4	Lock nut	HPb59-T	1
5	O-ring	NBR	1

### Technical Data

- Fields of Applications: Water
- Max. Working Pressure: PN10
- Operating Temp. Range: 0 to +70°C
- Max. working temperature: Up to 70°C with occasional excursions  
Up to 90°C max for period of 1 hour

### Applicable Standards

- Valves are manufactured to: BS2879-2
- Capillary end complies with: ISO 228
- WRAS Approved

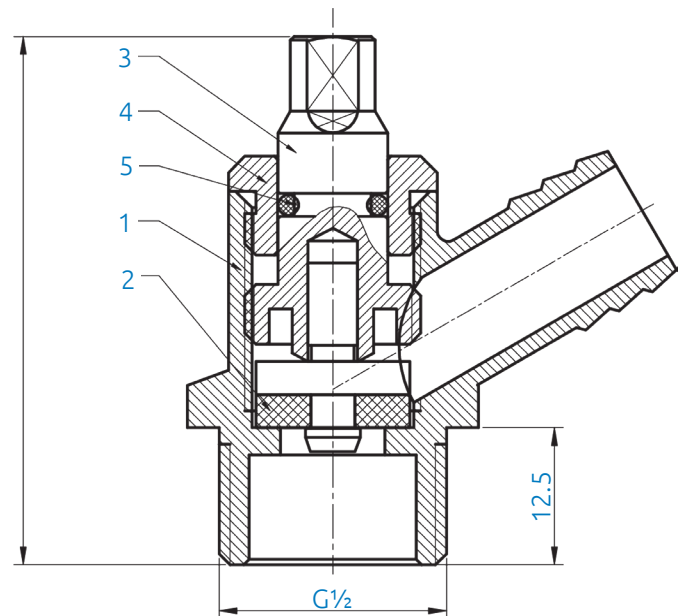

# Male BSP Tail 3/4"

## Drain-Off Cock

### DOC 05



### Features & Benefits

- For hot and cold water systems
- 3/4" BSP Male connections
- Square drive drain valve operation

### Versions & Product Codes

STOCK NO.	SIZE
31149	3/4"

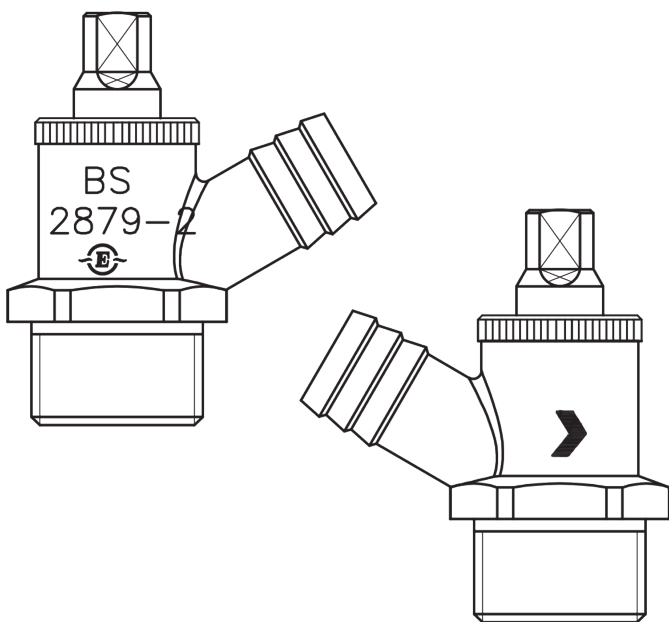

### Technical Data

- Fields of Applications: Water
- Max. Working Pressure: PN10
- Operating Temp. Range: 0 to +70°C
- Max. working temperature: Up to 70°C with occasional excursions  
Up to 90°C max for period of 1 hour

### Applicable Standards

- Valves are manufactured to: BS2879-2
- Capillary end complies with: ISO 228
- WRAS Approved

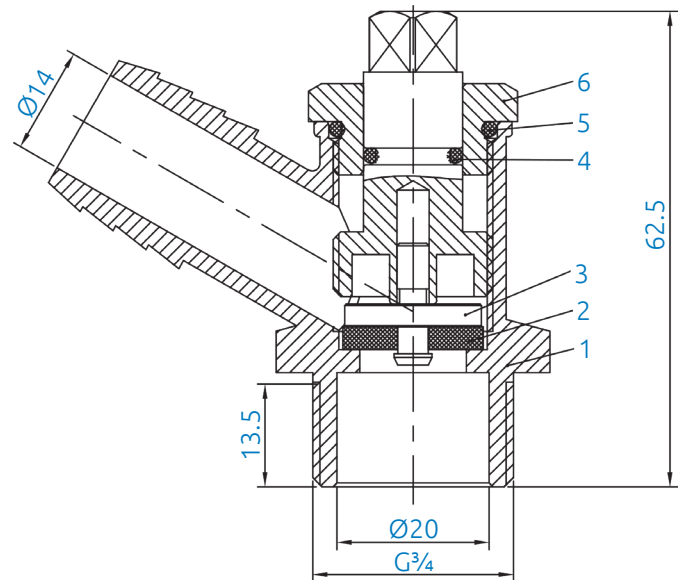

### Material Specifications

NO	NAME	MATERIAL	QUANTITY
1	Body	HPb59-T	1
2	Washer	EPDM	1
3	Stem	HPb59-T	1
4	O-ring	NBR	1
5	O-ring	NBR	1
6	Lock-nut	HPb59-T	1

# Auto Air Vent

## AVE 01



### Features & Benefits

- Automatic air venting during operation
- Suitable for heating/cooling or sanitary
- Can discharge large quantities of air
- Avoids negative phenomenon

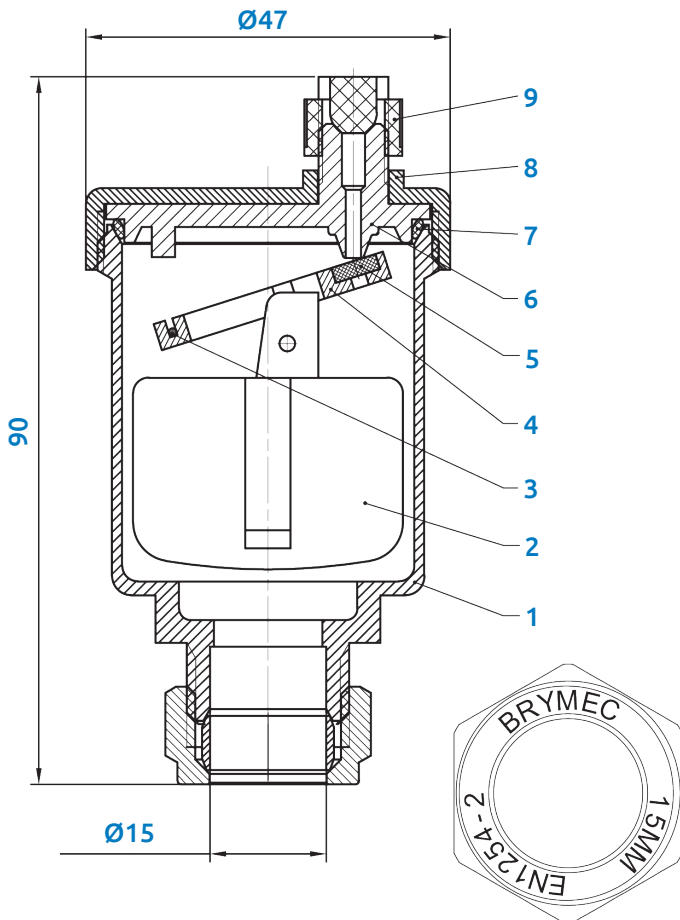

### Technical Data

- Fields of Applications: Water & glycol solutions
- Max. Working Pressure: PN10
- Max. working temperature: 110°C

### Applicable Standards

- Compression connections comply with EN1254-2
- Male thread connection are to: ISO 228

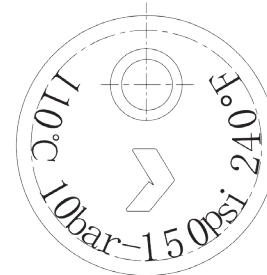
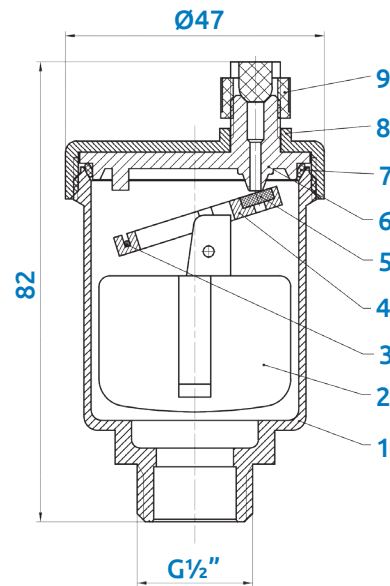

### Material Specifications

NO	NAME	MATERIAL	QUANTITY
1	Body	HPb59-T	1
2	Balance Weight	PP	1
3	Tension Spring	SS302	1
4	Plastic Plate	POM	1
5	Rubber Gasket	EPDM	1
6	Cover	POD	1
7	O-Ring	EPDM	1
8	Pressure Cover	HPb59-T	1
9	Plastic Cap	POM	1
10	Compression nut	HPb59-T	1
11	Olive	T2	1

### Versions & Product Codes

STOCK NO.	SIZE	CONNECTION TYPE
36250	15mm	Compression
36254	1/2"	Male Thread

# Auto Air Vent with Check Valve

## AVE 02



### Technical Data

- Fields of Applications: Water & glycol solutions
- Max. Working Pressure: PN10
- Max. working temperature: 110°C

### Applicable Standards

- Male thread connection are to: ISO 228



### Features & Benefits

- Automatic air venting during operation
- Suitable for heating/cooling or sanitary
- Can discharge large quantities of air
- Check valve allows service and maintenance without draining system

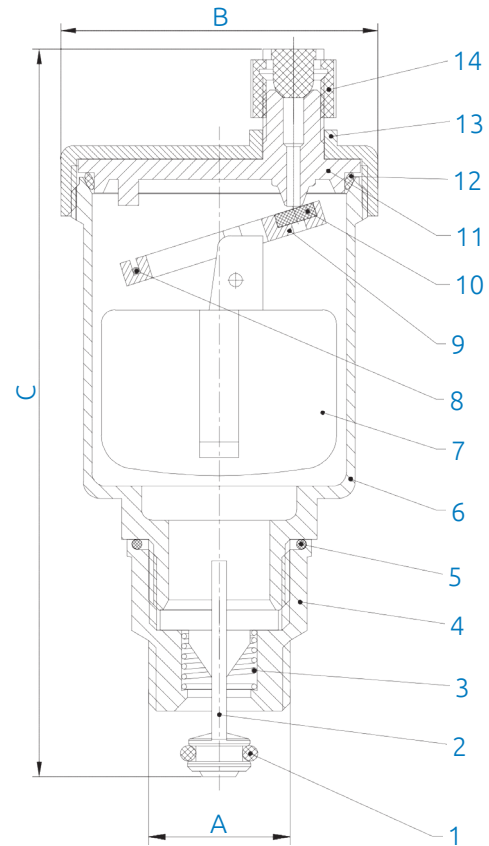

### Versions & Product Codes

STOCK NO.	SIZE	A	B	C
36257	15mm	3/8"	48	106
30849	1/2"	1/2"	47	107

### Material Specifications

NO	NAME	MATERIAL	QUANTITY
1	O-ring	EPDM	1
2	Plastic Bar	PP	1
3	Spring	SS302	1
4	Connection Nut	HPb59-T	1
5	O-ring	EPDM	1
6	Body	HPb59-T	1
7	Balance Weight	PP	1
8	Tension Spring	SS302	1
9	Plastic Plate	POM	1
10	Rubber Gasket	EPDM	1
11	Cover	POM	1
12	O-ring	EPDM	1
13	Pressure Cover	HPb59-T	1
14	Plastic Cap	POM	1

# Solenoid Valve

## SOL 01



### Technical Data

- Field of application: Water
- Maximum Working Pressure: PN16
- Working Temperature: -20°C to +120°C

### Applicable Standards

- Thread Standard ISO 228/1
- WRAS Approved



### Features and Benefits

- Normally Closed, Pilot Operated
- 230V as standard
- Brass Body, EPDM Diaphragm
- Alternatives sizes and materials available
- Normally Open & zero pressure differential versions
- 12VDC, 24VDC, 24VAC & 110VAC options
- WRAS Approval and performance tested

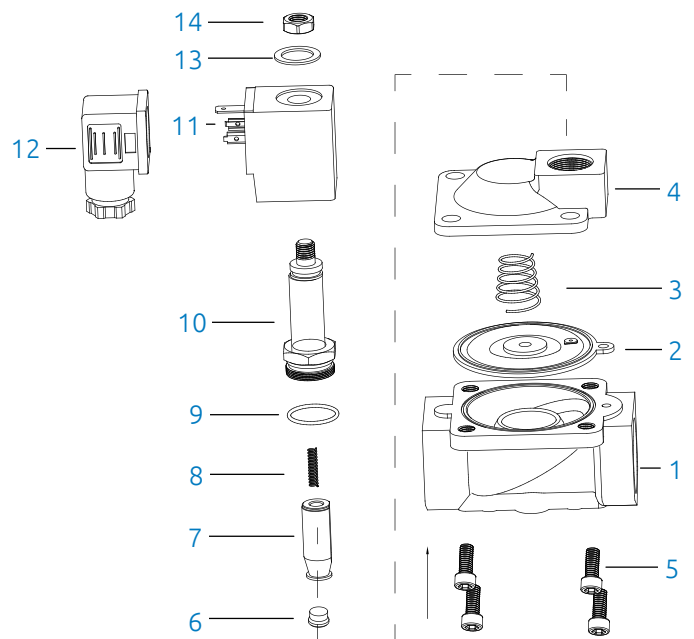
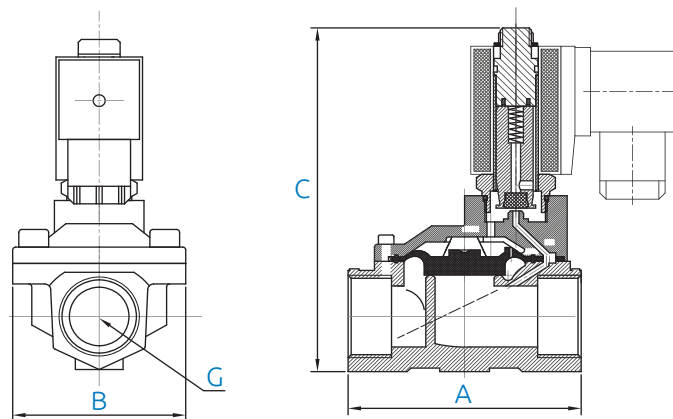

### Versions and Products Codes

STOCK NO	DN	G	A	B	C
36590	1/2"	1/2"	66	48	112
36591	3/4"	3/4"	75	58	118
36592	1"	1"	96	70	131
36593	1 1/4"	1 1/4"	131	96	146
36594	1 1/2"	1 1/2"	131	96	146
36595	2"	2"	165	120	167

### Material Specifications

PART NO	PART NAME	MATERIAL
1	Valve Body	Brass/Stainless Steel 316
2	Diaphragm	NBR / EPDM / Viton
3	Diaphragm Spring	Stainless Steel 304
4	Valve Cover	Brass/Stainless Steel 316
5	Bolt	Stainless Steel 302
6	Pilot Seal	NBR / EPDM / Viton
7	Pilot	Stainless Steel 1J117
8	Pilot Spring	Stainless Steel 304
9	O Ring	NBR / EPDM / Viton
10	Plunger Tube Unit	Stainless Steel 304 + 1J117
11	Coil	Enamelled Wire
12	Plug	Nylon
13	Washer	Stainless Steel 302
14	Lock Nut	Stainless Steel 302

# Stop Cock WRAS Approved - Compression



## Features and Benefits

- Brass body with compression ends
- For use with copper pipework systems
- WRAS Approved

## Applicable Standards

- Valves are manufactured to: EN1213
- Compression connections comply with: EN1254-2
- WRAS approved

## Product Codes and Dimensions

STOCK NO	A (mm)	B (mm)	C (mm)
36384	15	77.2	86
36385	22	102.5	101.5
36386	28	106.3	102.5

## Technical Data

- Suitable for Copper pipework systems
- Max. Working Pressure: 16 bar (<30°C); 10 BAR (30-85°C)
- Operating Temp: -10 ~ +85°C

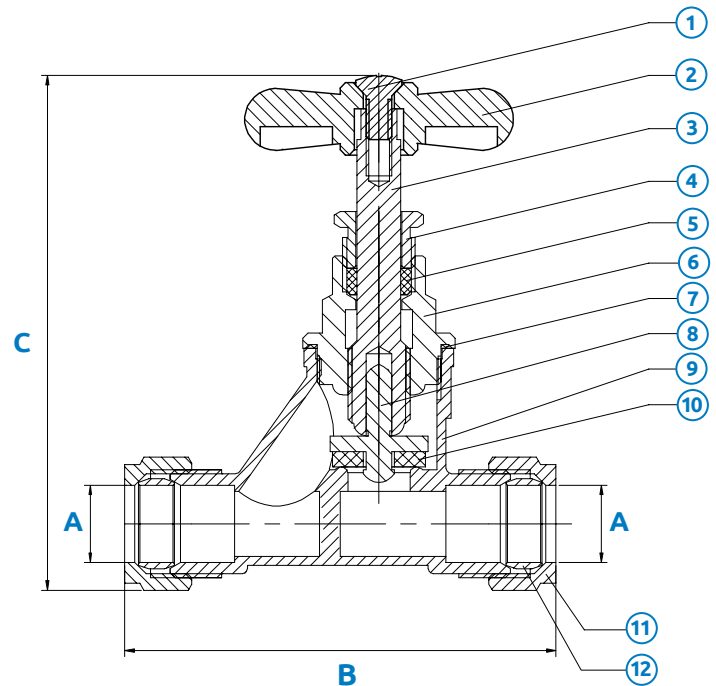

## Material Specifications

NO	NAME	MATERIAL	QUANTITY
1	Screw	HPb59- T	1
2	Handle	HPb59- T	1
3	Stem	HPb59- T	1
4	Lock Nut	HPb59- T	1
5	Packing	PTFE	1
6	Bonnet	HPb59- T	1
7	Sealing Gasket	PTFE	1
8	Seat	HPb59- T	1
9	Body	HPb59- T	1
10	Rubber Gasket	EPDM	1
11	Compression Nut	HPb59- T	2
12	Olive	T2	2